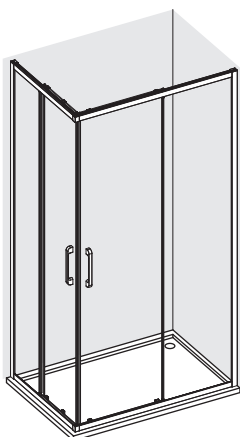
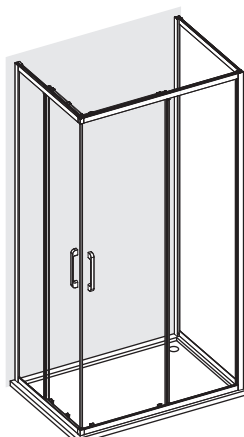
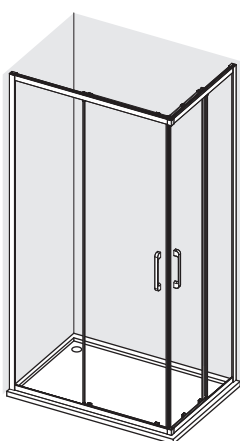
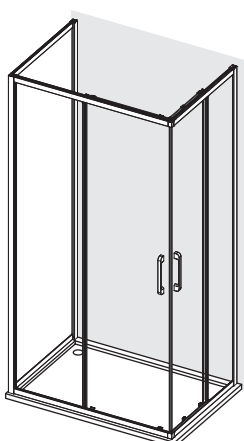

A1**B1****A2****B2**

EN Rectangular

FR Rectangulaire

PL Kabina prostokątna

RO Cabină de duș dreptunghiulară

ES Rectangular

PT Retangular

EN IMPORTANT - These instructions are for your safety. Please read through them thoroughly prior to handling the product and retain them for future reference.

FR IMPORTANT : Ces instructions sont données pour votre sécurité. Merci de les lire attentivement avant de manipuler le produit et de les conserver pour référence.

PL WAŻNE — Niniejsza instrukcja została opracowana w celu zapewnienia bezpieczeństwa użytkownikowi. Należy ją dokładnie przeczytać przed obsługą produktu i zachować do wykorzystania w przyszłości.

RO IMPORTANT - Aceste instrucțiuni sunt pentru siguranța ta. Citește-le cu atenție înainte de montarea produsului și păstrează-le pentru consultare ulterioară.

ES IMPORTANTE: Estas instrucciones son para su propia seguridad. Léelas atentamente antes de manipular el producto y guárdelas para futuras consultas.

PT IMPORTANTE - Estas instruções são para sua segurança. Leia-as atentamente antes de manusear o produto e guarde-as para consultas futuras.

5063022658630

5063022658296

5063022755919

5063022755865

5063022755926

5063022755933

EN You will need **FR** Vous aurez besoin de **PL** Będziesz potrzebować **RO** Vei avea nevoie de **ES** Necesitará **PT** Vai precisar de

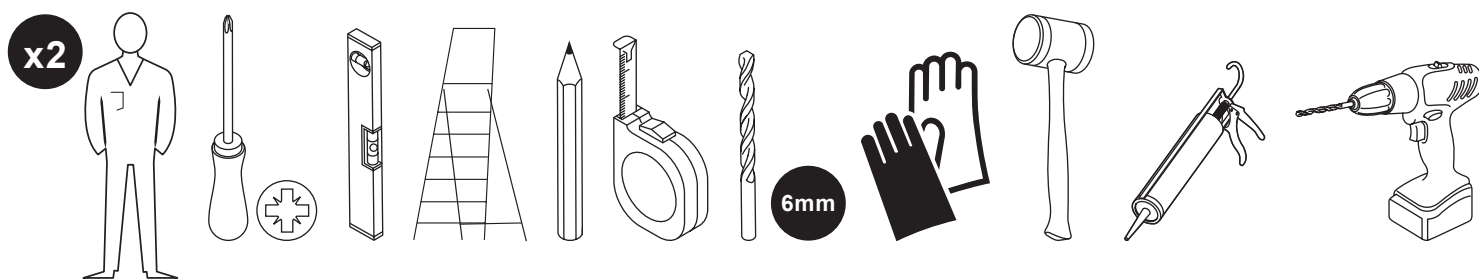

EN Contents **FR** Table des matières **PL** Spis treści **RO** Cuprins
ES Contenido **PT** Conteúdo

| EN | FR | PL | RO | ES | PT | | | | | | |
|-------------------------------|----|--------------------------|----|---------------------------|----|--------------------------|----|--------------------------|----|-----------------------|----|
| Product description | 3 | Description du produit | 3 | Opis produktu | 3 | Descrierea produsului | 3 | Descripción del producto | 3 | Descrição do produto | 3 |
| Safety | 5 | Sécurité | 6 | Bezpieczeństwo | 8 | Siguranță | 10 | Seguridad | 11 | Segurança | 13 |
| Guarantee | 5 | Garantie | 7 | Gwarancja | 9 | Garanție | 10 | Garantía | 12 | Garantia | 13 |
| Installation | 15 | Installation | 15 | Instalacja | 15 | Instalare | 15 | Instalación | 15 | Instalação | 15 |
| Care & maintenance | 90 | Entretien et maintenance | 90 | Czyszczenie i konserwacja | 90 | Îngrijire și întreținere | 91 | Cuidados y mantenimiento | 91 | Cuidados e manutenção | 91 |

EN Parts **FR** Pièces **PL** Części **RO** Piese **ES** Piezas **PT** Peças

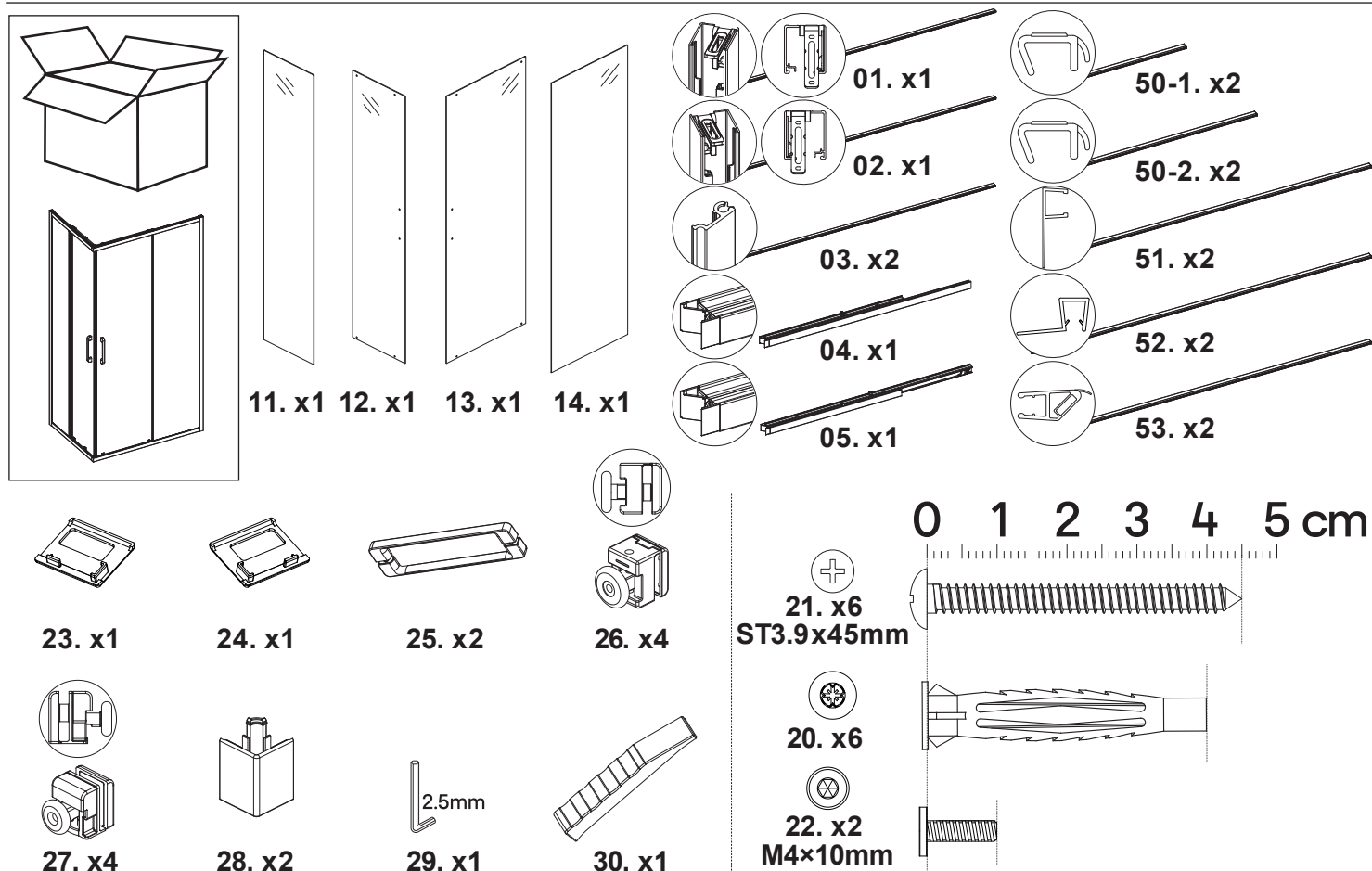

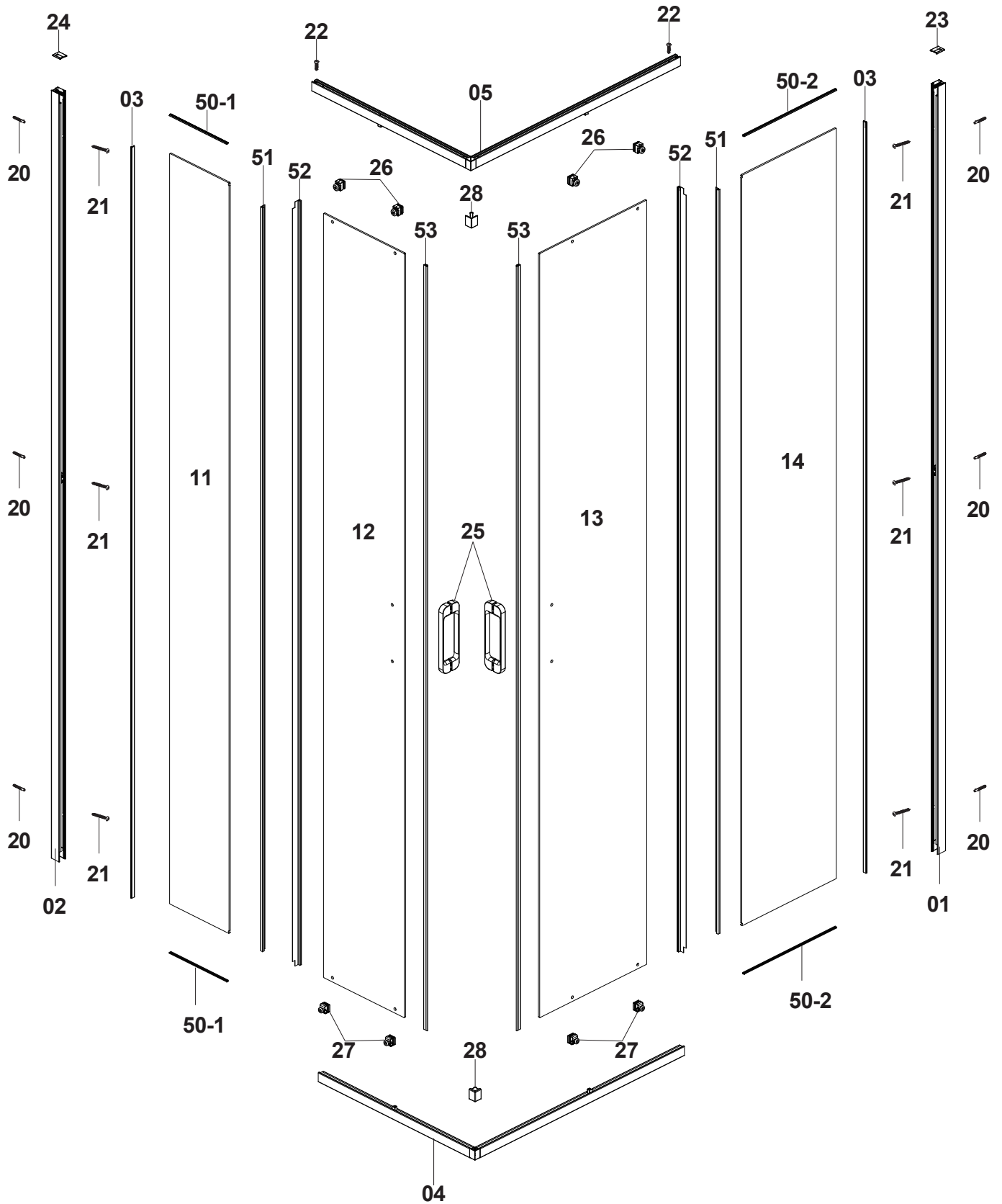

EN Product description **FR** Description du produit **PL** Opis produktu
RO Descrierea produsului **ES** Descripción del producto
PT Descrição do produto

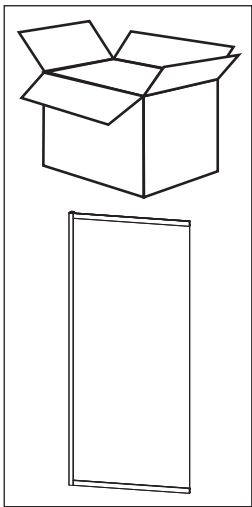

15. x1

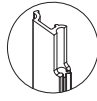

08. x1

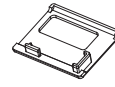

23. x1

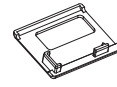

24. x1

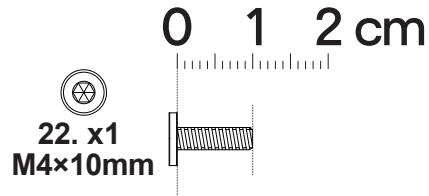

22. x1
M4x10mm

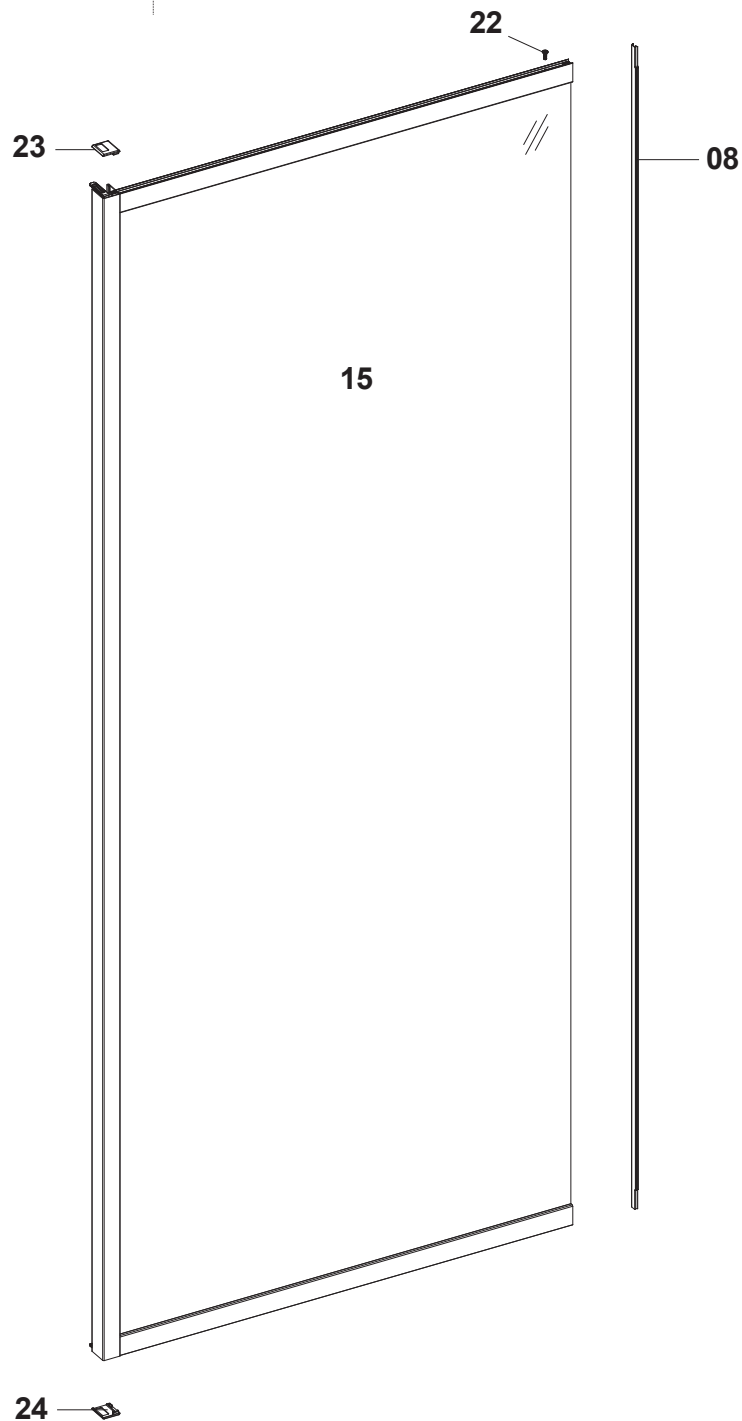



EN Getting Started

- Check the pack and ensure that you have all of the parts listed.
- When you are ready to start, make sure you have the right tools to hand, plenty of space and a dry area for assembly.
- Ensure the mounting surface is sound, clean and dry before the enclosure is installed.
- The enclosure is designed to allow for 20mm adjustment when fitted to 'out of true walls'.
- The thickness of the tiles used will affect the overall position of the enclosure.
- When drilling through ceramic tiles use a specialist drill bit.
- When working near a tray or bath, ensure that the waste is covered so that small parts do not fall down it.
- Please note: The wall plugs included with this product are suitable for solid walls only. Other wall types may require specialist fixings or wall plugs (not provided). Always ensure that wall plugs or fittings are correct for the wall type. If in doubt seek professional advice.
- Please note that although these instructions are comprehensive, it is always recommended that a technically competent installer should undertake the installation.

Safety

- For domestic use only.



CAUTION: FRAGILE - HANDLE THE PRODUCT WITH CARE. THIS PRODUCT MAY CAUSE PERSONAL INJURY, PROPERTY DAMAGE OR BREAK EASILY IF NOT HANDLED, POSITIONED AND INSTALLED WITH CARE.



CAUTION: PLEASE HANDLE ALL GLASS WITH CARE. ANY DAMAGE TO THE EDGES, OR SCRATCHES TO THE SURFACE THAT OCCUR DURING ASSEMBLY OR NORMAL USE CAN CAUSE THE GLASS TO

BREAK SUDDENLY. TEMPERED GLASS WILL SHATTER INTO VERY SMALL PIECES THAT WILL STILL HAVE SHARP EDGES.

- Do not strike the glass with hard or pointed items.
- Do not attempt to cut the glass.



CAUTION: ALWAYS ENSURE THE PRODUCT IS SECURELY INSTALLED BEFORE USE.

- Care should be taken when drilling into walls to avoid any hidden pipes or wires.



CAUTION: WHEN DRILLING THROUGH CERAMIC TILES USE A SPECIALIST DRILL BIT.



CAUTION: DO NOT OVERTIGHTEN THE FIXINGS OTHERWISE IT MAY DAMAGE THE PRODUCT.



WARNING: FAILURE TO FOLLOW THESE INSTRUCTIONS MAY RESULT IN PERSONAL INJURY, DAMAGE TO THE PRODUCT AND PROPERTY DAMAGE.

Guarantee

We take special care to select high quality materials and use manufacturing techniques that allow us to create products incorporating design and durability. This product has a manufacturer's guarantee of 10 years against manufacturing defects, from the date of purchase (if bought in store) or date of delivery (if bought online), at no additional cost for normal (non-professional or commercial) household use.

To make a claim under this guarantee, you must present your proof of purchase (such as a sales receipt, purchase invoice or other evidence admissible under applicable law), please keep your proof of purchase in a safe place. For this guarantee to apply, the product you purchased must be new, it will not apply to second hand or display products.

Unless stated otherwise by applicable law, any replacement product issued under this guarantee will only be guaranteed until expiry of the original period guarantee period.

This guarantee covers product failures and malfunctions provided the product was used for the purpose for which it is intended and subject to installation, cleaning, care and maintenance in accordance with the information contained in these terms and conditions, in the user manual and standard practice, provided that standard practice does not conflict with the user manual.

This guarantee does not cover defects and damage caused by normal wear and tear or damage that could be the result of improper use, faulty installation or assembly, neglect, accident, misuse, or modification of the product. Unless stated otherwise by applicable law, this guarantee will not cover, in any case, ancillary costs (shipping, movement, costs of uninstalling and reinstalling, labour etc), or direct and indirect damage.

If the product is defective, we will, within a reasonable time, replace or spare parts.

The warranty does not cover the breakage of tempered glass enclosures when it occurs during unpacking, assembly, or transportation of the product.

Rights under this guarantee are enforceable in the country in which you purchased this product. Guarantee related queries should be addressed to the store you purchased this product from.

The guarantee is in addition to and does not affect your statutory rights.

IMPORTANT - RETAIN THIS INFORMATION FOR FUTURE REFERENCE: READ CAREFULLY

FR

Pour bien commencer

- Vérifiez le contenu du paquet et assurez-vous que tous les composants répertoriés sont présents.
- Lorsque vous êtes prêt pour commencer, veillez à disposer des bons outils à portée de main, de suffisamment d'espace et d'un endroit sec pour le montage.

- Assurez-vous que la surface de montage est solide, propre et sèche avant l'installation de la paroi.
- Assurez-vous que la paroi est fixée à un bac au sol nivelé et à des murs verticaux.
- L'épaisseur des carreaux utilisés affectera la position d'ensemble de la paroi.
- Lors de perçages dans des carreaux en céramique, utilisez un foret adapté.
- Lors de travaux effectués à proximité d'un bac ou d'une baignoire, assurez-vous que les ouvertures soient couvertes afin qu'aucun petit morceau n'y tombe.
- Remarque : les chevilles murales fournies avec ce produit conviennent pour les murs pleins uniquement. Les autres types de murs peuvent éventuellement nécessiter des fixations ou chevilles murales spéciales (non fournies). Assurez-vous toujours que les chevilles murales ou fixations sont adaptées au type de mur. En cas de doute, obtenez des conseils professionnels.
- Remarque importante : Bien que ces instructions soient complètes, il est toujours recommandé que l'installation soit réalisée par un installateur professionnel.

Sécurité

- Utilisation domestique uniquement.



ATTENTION : FRAGILE - MANIPULEZ LE PRODUIT AVEC PRÉCAUTION. CE PRODUIT PEUT CAUSER DES BLESSURES, DES DOMMAGES MATÉRIELS OU SE CASSER FACILEMENT S'IL N'EST PAS MANIPULÉ, DISPOSÉ ET INSTALLÉ AVEC SOIN..



ATTENTION : VEUILLEZ MANIPULEZ TOUTE VITRE AVEC PRÉCAUTION. TOUT ENDOMMAGEMENT DES BORDS OU RAYURE SUR LA SURFACE SUSCEPTIBLE DE SE PRODUIRE EN COURS DE MONTAGE OU D'UTILISATION NORMALE PEUT PROVOQUER LA CASSURE SOUDAINE DE LA VITRE. LE VERRE PEUT VOLER EN PETITS ÉCLATS, DONT LES BORDS SONT TOUT DE MÊME TRANCHANTS.

- Ne cognez pas la vitre avec des objets durs ou pointus
- Ne tentez pas de découper la vitre.



ATTENTION : ASSUREZ-VOUS TOUJOURS QUE LE PRODUIT EST CORRECTEMENT INSTALLÉ AVANT DE L'UTILISER

- Des précautions doivent être prises lors des perçages dans le mur pour éviter les tuyaux et les fils cachés



ATTENTION : LORS DE PERÇAGES DANS DES CARREAUX EN CÉRAMIQUE, UTILISEZ UN FORET SPÉCIAL.



ATTENTION : NE SERREZ PAS LES FIXATIONS EXCESSIVEMENT. CELA POURRAIT ENDOMMAGER LE PRODUIT.



AVERTISSEMENT : LE NON-RESPECT DE CES INSTRUCTIONS PEUT ENTRAÎNER DES BLESSURES CORPORELLES, DES DOMMAGES AU PRODUIT ET DES DOMMAGES À LA PROPRIÉTÉ.

Garantie

Nous veillons tout particulièrement à sélectionner des matériaux de haute qualité et à utiliser des techniques de fabrication qui nous permettent de créer des produits à la fois design et durables. Ce produit bénéficie d'une garantie fabricant de 10 ans couvrant les défauts de fabrication à compter de la date d'achat (en cas d'achat en magasin) ou de la date de livraison (en cas d'achat sur Internet), sans coût supplémentaire pour une utilisation domestique normale (non commerciale ni professionnelle).

Pour déposer une réclamation au titre de cette garantie, vous devez présenter votre preuve d'achat (ticket de caisse, facture d'achat ou toute autre preuve recevable en vertu de la loi en vigueur). Conservez votre preuve d'achat dans un endroit sûr. Pour que cette garantie soit applicable, le produit que vous avez acheté doit être neuf. La garantie ne s'applique pas aux produits d'occasion ou aux modèles d'exposition. Sauf indication contraire

prévue par la loi en vigueur, tout produit de remplacement fourni au titre de la présente garantie ne sera garanti que jusqu'à expiration de la période de garantie initiale.

Cette garantie couvre les défaillances et dysfonctionnements du produit, sous réserve que le produit ait été utilisé conformément à l'usage pour lequel il a été conçu, qu'il ait été installé, nettoyé et entretenu conformément aux informations contenues dans les présentes conditions générales ainsi que dans le manuel d'utilisation, et conformément à la pratique, sous réserve que celles-ci n'aillent pas à l'encontre du manuel d'utilisation.

Cette garantie ne couvre pas les défauts et dommages causés par l'usure normale ni les dommages pouvant résulter d'une utilisation non conforme, d'une installation ou d'un assemblage défectueux, ou d'une négligence, d'un accident, d'une mauvaise utilisation ou d'une modification du produit. Sauf indication contraire prévue par la loi en vigueur, cette garantie ne couvre en aucun cas les coûts accessoires (expédition, transport, frais de désinstallation et réinstallation, main d'œuvre, etc.), ni les dommages directs et indirects.

Si le produit est défectueux, nous nous engageons, dans un délai raisonnable, à le remplacer ou le fournir les pièces de rechange.

La garantie ne couvre pas la casse des parois en verre trempé lorsqu'elle intervient durant le déballage, le montage ou le transport du produit.

Cette garantie est valable dans le pays où vous avez acheté ce produit. Toute demande au titre de la garantie doit être adressée au magasin où vous avez acheté ce produit.

Cette garantie s'ajoute à vos droits au titre de la loi, sans les affecter.

Si vous avez acheté ce produit en France, en plus de cette garantie commerciale, le vendeur reste tenu de respecter la garantie légale de conformité prévue par les articles L217-4 à L217-14 du Code de la consommation et aux articles qui concernent les vices cachés de la chose vendue dans les conditions prévues aux articles 1641 à 1648 et 2232 du Code civil. Le distributeur auprès duquel vous avez acheté ce produit répond de tout défaut de conformité ou vice caché du produit, conformément aux présentes dispositions.

En vertu de l'article L217-16 du Code de la consommation, lorsque l'acheteur demande au vendeur, pendant la durée de la garantie commerciale qui lui a été consentie lors de l'acquisition ou de la réparation d'un bien meuble,

une remise en état couverte par la garantie, toute période d'immobilisation d'au moins sept jours vient s'ajouter à la durée de la garantie qui reste à courir. Cette période court à compter de la demande d'intervention de l'acheteur ou de la mise à disposition pour réparation du bien en cause, si cette mise à disposition est postérieure à la demande d'intervention. Garantie légale de conformité (extrait du Code de la consommation) : Article L217-4 du Code de la consommation - Le vendeur doit livrer un bien conforme au contrat et répond des défauts de conformité existant lors de la livraison. Il répond également des défauts de conformité résultant de l'emballage, des instructions de montage ou de l'installation lorsque celle-ci a été mise à sa charge par le contrat ou a été réalisée sous sa responsabilité. Article L217-5 du Code de la consommation - Le bien est conforme au contrat : 1. S'il est adapté à l'objectif généralement prévu pour des biens similaires et, le cas échéant : s'il correspond à la description donnée par le vendeur et possède les qualités présentées par le vendeur à l'acheteur sous forme d'échantillon ou de modèle ; s'il présente des qualités que l'acheteur peut légitimement attendre au regard des déclarations publiques faites par le vendeur, par le fabricant ou par son représentant, notamment dans la publicité ou l'étiquetage ; 2. Ou s'il présente les caractéristiques définies d'un commun accord par les parties ou est propre à tout usage spécial recherché par l'acheteur, porté à la connaissance du vendeur et que ce dernier a accepté. Article L217-12 du Code de la consommation - Toute réclamation suite à un défaut de conformité est limitée à deux ans à compter de la livraison du bien. Garantie légale sur les vices cachés (extrait du Code de la consommation) : Article 1641 du Code civil - Le vendeur est tenu de la garantie en cas de défauts cachés de la chose vendue qui la rendent impropre à l'usage auquel on la destine, ou qui diminuent tellement cet usage que l'acheteur ne l'aurait pas acquise, ou n'en aurait donné qu'un moindre prix, s'il les avait connus. Article 1648 du Code civil (alinéa 1) - Toute réclamation résultant de vices cachés doit être faite par l'acheteur dans un délai de deux ans à compter de la découverte du vice.

**IMPORTANT - A
CONSERVER POUR
CONSULTATION
ULTERIEURE : A LIRE
SOIGNEUSEMENT**

PL

Pierwsze kroki

- Sprawdź zawartość opakowania, aby upewnić się, że znajdują się w nim wszystkie części.
- Przed rozpoczęciem montażu upewnij się, że posiadasz odpowiednie narzędzia, wystarczająco dużo miejsca oraz suchą przestrzeń pod montaż.
- Przed rozpoczęciem instalacji kabiny upewnij się, że powierzchnia montażu jest stabilna, czysta i sucha.
- Upewnij się, że kabina została przymocowana do wypoziomowanego brodzika lub podłogi oraz do pionowej ściany.
- Grubość położonych na ścianie kafelków ma wpływ na ostateczną pozycję ułożenia kabiny na brodziku.
- Do wiercenia przez kafelki ceramiczne używaj specjalnego wiertła.
- Podczas pracy w okolicy brodzika lub wanny, upewnij się, że odpływ jest zamknięty, dzięki czemu małe części nie mogą do niego wpaść.
- Informacja: Kołki rozporowe dołączone do produktu są przeznaczone wyłącznie do montażu na litych ścinach. Montaż na ścianach innego typu wymaga specjalnych elementów montażowych lub kołków rozporowych (nie dołączone). Zawsze upewnij się, że kołki rozporowe i elementy montażowe są właściwie dobrane dla danego typu ściany. W razie wątpliwości zasięgnij porady specjalisty.
- Pamiętaj. Pomimo, że instrukcje instalacji są kompleksowe, to zawsze zalecane jest przeprowadzenie montażu przez wykwalifikowanego fachowca.

Bezpieczeństwo

- Produkt przeznaczony do użytku domowego.



**UWAGA: SZKŁO - BĄDŹ
OSTROŻNY PODCZAS
OBCHODZENIA SIĘ Z
PRODUKTEM. NINIEJSZY
PRODUKT MOŻE
DOPROWADZIĆ DO URAZU
UŻYTKOWNIKA, USZKODZENIA
MIENIA LUB MOŻE STŁUC SIĘ,
JEŚLI NALEŻYTA OSTROŻNOŚĆ
NIE ZOSTANIE ZACHOWANA
PODCZAS INSTALACJI.**



UWAGA: PROSZĘ ZACHOWAĆ OSTROŻNOŚĆ PODCZAS OBCHODZENIA SIĘ Z SZYBAMI. JAKIEKOLWIEK USZKODZENIA KRAWĘDZI LUB ZADRAPANIA POWIERZCHNI SPOWODOWANE PODCZAS MONTAŻU BĄDŹ NORMALNEGO UŻYCIA, MOGĄ DOPROWADZIĆ DO NAGŁEGO STŁUCZENIA SIĘ SZYBY. SZKŁO HARTOWANE ROZKRUSZY SIĘ NA BARDZO MAŁE KAWAŁKI Z OSTRYMI KRAWĘDZIAMI.

- Nie uderzaj w szyby twardymi lub spiczastymi przedmiotami.
- Nie przecinaj szyb.



UWAGA: PRZED UŻYCIEM ZAWSZE UPEWNIJ SIĘ, ŻE PRODUKT JEST BEZPIECZNIE ZAINSTALOWANY.

- Zachowaj ostrożność podczas wiercenia ściany, aby nie uszkodzić rur oraz przewodów elektrycznych.



UWAGA: DO WIERCENIA PRZEZ KAFELKI CERAMICZNE UŻYWAJ SPECJALNEGO WIERTŁA.



UWAGA: NIE DOKRĘCAJ MOCOWAŃ ZBYT MOCNO, GDYŻ MOŻE TO USZKODZIĆ PRODUKT.



OSTRZEŻENIE: NIE PRZESTRZEGANIE NINIEJSZYCH INSTRUKCJI MOŻE DOPROWADZIĆ DO URAZU UŻYTKOWNIKA, ZNISZCZENIA LUB USZKODZENIA MIENIA.

Gwarancji

Przykładamy szczególną wagę do tego, aby wybierać materiały wysokiej jakości i stosować techniki produkcyjne, które umożliwiają tworzenie wytrzymałych, a zarazem atrakcyjnych produktów. Ten produkt ma gwarancję producenta na 10 lat, która obejmuje wady produkcyjne, począwszy od daty zakupu (zakup w sklepie) lub dostawy (zakup przez Internet) bez dodatkowych kosztów w przypadku normalnego (nieprofesjonalnego lub niekomercyjnego) użytku domowego.

Aby dokonać zgłoszenia reklamacyjnego, należy przedstawić dowód zakupu (np. paragon, fakturę lub inny dowód na mocy obowiązujących przepisów prawa). Dowód zakupu należy przechowywać w bezpiecznym miejscu. Gwarancja obejmuje produkty nowe; nie obejmuje produktów używanych lub z ekspozycji. Produkt zamienny objęty niniejszą gwarancją będzie nią objęty aż do wygaśnięcia okresu obowiązywania gwarancji oryginalnego produktu, chyba że określono inaczej w obowiązujących przepisach prawa.

Niniejsza gwarancja obejmuje wady i uszkodzenia produktu, pod warunkiem że produkt był używany zgodnie z przeznaczeniem oraz zamontowany, czyszczony i konserwowany zgodnie z informacjami zawartymi powyżej oraz w instrukcji obsługi, a także ze standardowymi praktykami (jeśli te praktyki nie są sprzeczne z instrukcją użytkownika).

Niniejsza gwarancja nie obejmuje wad ani uszkodzeń wynikających z normalnego zużycia lub uszkodzeń będących skutkiem niewłaściwego używania, montażu lub złożenia, a także zaniedbania, wypadku i modyfikacji produktu. Gwarancja nie obejmuje w żadnym wypadku dodatkowych kosztów (transportu, przenoszenia, montażu i demontażu, robocizny itd.) ani strat bezpośrednich lub pośrednich, chyba że określono inaczej w obowiązujących przepisach prawa.

Jeśli produkt jest wadliwy, we właściwym czasie wymienimy lub zapewnimy części zamienne.

Gwarancja nie obejmuje zbita drzwi ze szkła hartowanego które nastąpiło podczas rozpakowywania, montażu lub transportu produktu.

Prawa wynikające z tej gwarancji obowiązują w kraju, w którym zakupiono produkt. Zapytania dotyczące gwarancji powinno się kierować do sklepu, w którym zakupiono produkt.

Niniejsza gwarancja jest dokumentem dodatkowym, który nie ma wpływu na ustawowe prawa konsumenta.

Jeśli produkt zakupiono w Polsce, niniejsza gwarancja nie wyklucza, nie ogranicza ani nie zawiesza uprawnień wynikających z przepisów prawa dotyczących gwarancji na wady zakupionego towaru.

**WAŻNE - ZACHOWAJ
TE INFORMACJE DO
WYKORZYSTANIA
W PRZYSZŁOŚCI:
PRZECZYTAJ
UWAŻNIE**

RO

Pentru început

- Verificați pachetul și asigurați-vă că toate componentele trecute pe listă sunt prezente.
- Când sunteți gata, asigurați-vă că aveți sculele adecvate la îndemână, suficient spațiu și o zonă uscată pentru asamblare.
- Asigurați-vă că suprafața de montare este adecvată, curată și uscată înainte de instalarea cabinei de duș.
- Asigurați-vă că produsul este montat pe o cădiță sau sol drept și i pereți verticali.
- Cabina este proiectată pentru a permite o reglare de 20mm când este montată între pereți autentici.
- Grosimea plăcilor de faianță utilizate va influența poziția generală a cabinei pe cădița de duș.
- Când găuriți prin plăci ceramice, utilizați un burghiu specializat.
- Când lucrați în apropierea unei cădițe sau căzi de baie, asigurați-vă că gaura de scurgere este acoperită astfel încât să se împiedice căderea pieselor mici în aceasta.
- Vă rugăm, notați: Diblurile incluse cu acest produs sunt adecvate numai pentru pereți solizi. Alte tipuri de pereți pot necesita elemente profesionale de fixare sau dibluri (neincluse). Întotdeauna asigurați-vă că diblurile sau elementele de fixare sunt corecte pentru tipul de perete. În caz de dubiu, consultați un expert.
- Vă rugăm notați că deși aceste instrucțiuni sunt complete, întotdeauna se recomandă ca instalarea să fie executată de un instalator cu competențe tehnice.

Siguranța

- Numai pentru utilizare casnică.



ATENȚIE: FRAGIL - MANEVRAȚI PRODUSUL CU GRIJĂ. ACEST PRODUS POATE CAUZA RĂNI, PAGUBE SAU SE POATE SPARGE UȘOR DACĂ NU ESTE MANEVRAȚ, POZIȚIONAT ȘI INSTALAT CU GRIJĂ.



ATENȚIE: VĂ RUGĂM MANEVRAȚI CU GRIJĂ TOATE PRODUSELE DE STICLĂ. ORICARE DETERIORARE A MUCHIILOR SAU ZGÂRIETURI ALE SUPRAFETELOR CARE

POT AVEA LOC ÎN TIMPUL ASAMBLĂRII SAU A UTILIZĂRII NORMALE POT CAUZA SPARGEREA BRUSCĂ A STICLEI. STICLA CĂLITĂ SE VA SPARGE ÎN BUCĂȚELE FOARTE MICI CARE VOR AVEA MUCHII ASCUȚITE.

- Nu loviți sticla cu articole ascuțite sau dure.
- Nu încercați să tăiați sticla.



ATENȚIE: ÎNTOTDEAUNA ASIGURAȚI-VĂ CĂ PRODUSUL ESTE BINE INSTALAT ÎNAINTEA UTILIZĂRII.

- Aveți grijă când dați găuri în pereți pentru a evita țevile sau firele electrice ascunse.



ATENȚIE: CÂND GĂURIȚI PRIN PLĂCI CERAMICE, UTILIZAȚI UN BURGHIU SPECIALIZAT.



ATENȚIE: NU STRÂNGEȚI EXCESIV FITINGURILE DEOARECE RISCAȚI SĂ AVARIAȚI PRODUSUL.



AVERTIZARE: NERESPECTAREA ACESTOR INSTRUCȚIUNI SE POATE SOLDA CU VĂTĂMARE CORPORALĂ, DETERIORAREA PRODUSULUI ȘI DETERIORAREA BUNURILOR.

Garanție

Avem o grijă deosebită să selectăm materiale de înaltă calitate și să utilizăm tehnici de fabricare care ne permit să creăm produse care încorporează designul și durabilitatea. Acest produs beneficiază de garanție din partea producătorului de 10 ani pentru defectele de fabricație, de la data achiziției (dacă este cumpărat din magazin) sau de la data livrării (dacă este cumpărat online), fără niciun cost suplimentar pentru uz casnic normal (nu profesional sau comercial).

Pentru a efectua o solicitare în temeiul acestei garanții, trebuie să prezentați dovada achiziției (cum ar fi, chitanța de vânzare/bonul fiscal, factura de achiziție sau alte dovezi admisibile conform legii aplicabile); vă rugăm să păstrați dovada achiziției într-un loc sigur. Pentru ca această garanție să

se aplice, produsul achiziționat trebuie să fie nou, garanția neaplicându-se pentru produse la mâna a doua sau produse de prezentare. Cu excepția cazului în care legislația aplicabilă prevede altfel, orice produs înlocuit livrat în baza prezentei garanții va beneficia de garanție doar până la expirarea perioadei inițiale de garanție.

Prezenta garanție acoperă defecțiunile produsului și erorile de funcționare, cu condiția ca produsul să fi fost utilizat în scopul prevăzut și să fi fost instalat, curățat, îngrijit și întreținut în conformitate cu informațiile conținute în termenii și condițiile prezente, manualul de utilizare și practicile standard, cu condiția ca practicile standard să nu fie în contradicție cu manualul de utilizare.

Această garanție nu acoperă defectele și deteriorările provocate de uzura normală sau daunele care pot fi rezultatul utilizării necorespunzătoare, instalării sau asamblării defectuoase, neglijenței, accidentelor, utilizării greșite sau modificărilor aduse produsului. Cu excepția cazului în care legislația aplicabilă prevede altfel, prezenta garanție nu va acoperi, în niciun caz, costurile suplimentare (de expediere, deplasare, dezinstalare și reinstalare, manoperă etc.) sau daunele directe și indirecte.

Dacă produsul este defect, vom proceda, într-un timp rezonabil, înlocuirea sau oferire piese de schimb.

Garanția nu acoperă spargerea pereților din sticlă temperată atunci când aceasta are loc în timpul despachetării, asamblării sau transportului produsului.

Drepturile acoperite de această garanție sunt aplicabile în țara în care ați achiziționat produsul. Întrebările legate de garanție trebuie adresate magazinului de la care ați achiziționat produsul.

Garanția este suplimentară drepturilor dvs. legale și nu le afectează.

Dacă achiziționați acest produs din Turcia sau România, veți primi o garanție.

**IMPORTANT -
PĂSTRAȚI ACESTE
INFORMAȚII PENTRU
CONSULTĂRI
VIITOARE: CITIȚI CU
ATENȚIE**

ES Empezando

- Compruebe y asegúrese de que cuenta con todos los componentes de la lista.
- Cuando esté listo para comenzar, asegúrese de que tiene a mano las herramientas adecuadas, mucho espacio y una zona seca para el montaje.
- Compruebe que la superficie del montaje sea sólida, esté limpia y seca antes de instalar la cabina.
- Asegúrese que la cabina esté ajustada a una bandeja nivelada o al piso y que las paredes están verticales.
- El grosor de los azulejos utilizados afectará la posición general en la cabina sobre la bandeja.
- Cuando taladre azulejos de cerámica utilice una broca especial para ello.
- Cuando trabaje cerca de una bandeja o una tina, asegúrese que el desagüe esté cubierto para que las partes pequeñas no caigan por ahí.
- Por favor tenga en cuenta: los tarugos de pared incluidos con este producto son aptos solo para muros sólidos. Otros tipos de muros podrían necesitar métodos de fijación especiales (no incluidos). Asegúrese siempre de que los tarugos o accesorios de instalación sean los correctos para el tipo de muro. Si tiene dudas al respecto, busque la ayuda de un profesional.
- Por favor tenga en cuenta que aunque estas instrucciones están completas, siempre se recomienda que un instalador competente técnicamente se haga cargo de la instalación.

Seguridad

- Para uso exclusivo doméstico.



PRECAUCIÓN: FRÁGIL - MANEJE EL PRODUCTO CON CUIDADO. ESTE PRODUCTO PUEDE CAUSAR LESIONES PERSONALES, DAÑOS A LA PROPIEDAD O ROMPERSE FÁCILMENTE SI NO SE MANEJA, COLOCA E INSTALA CON CUIDADO.



PRECAUCIÓN: POR FAVOR MANEJE EL VIDRIO CON CUIDADO. LOS BORDES PUEDEN DAÑARSE O LAS SUPERFICIES PUEDEN RAYARSE DURANTE EL MONTAJE O USO NORMAL

CAUSANDO QUE EL VIDRIO SE ROMPA REPENTINAMENTE. EL VIDRIO TEMPLADO SE DESMORONARÁ EN PEDAZOS MUY PEQUEÑOS QUE TENDRÁN BORDES AFILADOS.

- No golpee el vidrio con artículos duros o puntiagudos.
- No intente cortar el vidrio.



PRECAUCIÓN: ASEGÚRESE SIEMPRE DE QUE EL PRODUCTO ESTÁ INSTALADO DE FORMA SEGURA ANTES DE UTILIZARLO.

- Tenga cuidado al taladrar para evitar tuberías o cableado oculto.



PRECAUCIÓN: CUANDO TALADRE AZULEJOS DE CERÁMICA UTILICE UNA BROCA ESPECIAL PARA ELLO.



PRECAUCIÓN: NO APRIETE EN EXCESO LOS ELEMENTOS DE FIJACIÓN O PODRÍA DAÑAR EL PRODUCTO.



PRECAUCIÓN: NO SEGUIR ESTAS INSTRUCCIONES PUEDE DAR COMO RESULTADO LESIONES PERSONALES, DAÑO AL PRODUCTO Y DAÑOS A LA PROPIEDAD.

Garantía

Nos ocupamos especialmente en seleccionar materiales de alta calidad y usar técnicas de fabricación que nos permitan crear productos que aporten diseño y durabilidad. Este producto tiene una garantía del fabricante de 10 años frente a defectos de fabricación, a partir de la fecha de adquisición (si se adquiere en una tienda) o de entrega (si se adquiere por Internet), sin coste adicional para uso normal doméstico (ni profesional ni comercial).

Para presentar una reclamación en el marco de esta garantía, deberá presentar el comprobante de compra (como un recibo, factura de compra u otras pruebas admisibles en virtud de la ley aplicable); conserve su comprobante de compra en un lugar seguro. Para poder acogerse a esta garantía, el producto adquirido deberá ser nuevo; la garantía no se aplicará a productos de segunda mano o productos de exposición. A menos que

la legislación vigente indique lo contrario, todo producto de sustitución entregado conforme a esta garantía estará cubierto solo hasta la fecha de vencimiento de la garantía original.

La presente garantía cubre los fallos y anomalías del producto siempre y cuando este se haya utilizado para los fines para los que está destinado y que su instalación, limpieza, cuidado y mantenimiento se hayan efectuado de conformidad tanto con la información descrita en estos términos y condiciones y en el manual del usuario, como con la práctica habitual, siempre y cuando esta no entre en conflicto con el contenido del manual de usuario. Esta garantía no cubre defectos ni daños causados por el desgaste normal, ni daños que pudiesen ser resultado de usos indebidos, instalaciones o montajes deficientes, negligencia, accidente, uso indebido o modificación del producto. A menos que se indique lo contrario en la ley aplicable, esta garantía no cubre, bajo ningún concepto, los gastos accesorios (transporte, movimiento, costes de desinstalación y reinstalación, mano de obra, etc.) ni los daños directos o indirectos.

Si el producto es defectuoso, procederemos, en un plazo razonable, a su sustitución o reposición de piezas.

La garantía no cubre la rotura de las mamparas de vidrio templado cuando ésta se produce durante el desembalaje, el montaje o el transporte del producto.

Los derechos en virtud de esta garantía tendrán vigencia en el país donde haya adquirido el producto. Las consultas relacionadas con la garantía deberán dirigirse a la tienda en la que adquirió el producto. La garantía es complementaria y no afecta a sus derechos legales.

Si adquirió este producto en España, el distribuidor será responsable de las faltas de conformidad del producto según las disposiciones establecidas en los artículos 114 a 124 del Real Decreto Legislativo 1/2007, con fecha del 16 de noviembre, por el que se aprueba el texto refundido de la Ley General para la Defensa de los Consumidores y Usuarios y otras leyes complementarias.

**IMPORTANTE -
GUARDE ESTA
INFORMACIÓN
PARA FUTURAS
CONSULTAS: LEA
ATENTAMENTE**

PT

Iniciar

- Verifique a embalagem e certifique-se de que não faltam peças.
- Quando estiver pronto para começar, certifique-se de que tem as ferramentas necessárias e espaço suficiente numa zona seca para executar a montagem.
- Certifique-se de que a superfície de montagem está em boas condições, limpa e seca antes de instalar a divisória.
- Certifique-se de que a divisória é colocada numa base ou piso nivelado e com paredes verticais.
- A divisória foi concebida de forma a permitir um ajuste de 20mm quando instalada em “paredes falsas”.
- A espessura dos azulejos usados afeta a posição geral do fecho na base.
- Ao perfurar azulejos de cerâmica, utilize uma broca especial.
- Ao trabalhar junto de uma base de chuveiro ou banheira, certifique-se de que não existe a possibilidade de entrada de resíduos.
- Tenha em atenção o seguinte: As buchas incluídas neste produto adequam-se apenas a paredes sólidas. Outros tipos de parede poderão necessitar de acessórios de fixação ou buchas especiais (não fornecidos). Certifique-se sempre de que as buchas ou os acessórios de fixação adequam-se ao tipo de parede. Em caso de dúvida, consulte um profissional.
- Embora estas instruções sejam abrangentes, é sempre recomendável que a instalação seja executada por um profissional com as devidas qualificações.

Segurança

- Apenas para uso doméstico.



ATENÇÃO: FRÁGIL - MANUSEAR O PRODUTO COM CUIDADO. ESTE PRODUTO PODE CAUSAR LESÕES PESSOAIS, DANOS NA PROPRIEDADE OU PARTIR-SE FACILMENTE SE NÃO FOR MANUSEADO, POSICIONADO E INSTALADO COM CUIDADO.



ATENÇÃO: MANUSEIE TODAS AS PARTES DE VIDRO COM CUIDADO. QUAISQUER DANOS NAS EXTREMIDADES, OU

RISCOS NA SUPERFÍCIE, QUE OCORRAM DURANTE A MONTAGEM OU A UTILIZAÇÃO NORMAL PODEM FAZER COM QUE O VIDRO QUEBRE REPENTINAMENTE. O VIDRO TEMPERADO FRAGMENTA-SE EM VÁRIAS PEÇAS PEQUENAS QUE TERÃO EXTREMIDADES AGUÇADAS.

- Não bata no vidro com objetos rígidos ou pontiagudos.
- Não tente cortar o vidro.



ATENÇÃO: CERTIFIQUE-SE SEMPRE DE QUE O PRODUTO ESTÁ DEVIDAMENTE INSTALADO ANTES DE UTILIZÁ-LO.

- É necessário ter cuidado ao perfurar paredes para evitar qualquer tipo de tubagem ou cablagem.



ATENÇÃO: AO PERFURAR AZULEJOS DE CERÂMICA, UTILIZE UMA BROCA ESPECIAL.



ATENÇÃO: NÃO APERTE DEMASIADO OS ACESSÓRIOS DE FIXAÇÃO, CASO CONTRÁRIO, PODERÁ DANIFICAR O PRODUTO.



AVISO: O NÃO SEGUIMENTO DESTAS INSTRUÇÕES PODE DAR ORIGEM A LESÕES PESSOAIS, DANOS NO PRODUTO E DANOS DE PROPRIEDADE.

Garantia

Empenhamo-nos especialmente na seleção cuidada de materiais de elevada qualidade e utilizamos técnicas de fabrico que nos permitem criar produtos que incorporam design e durabilidade. Este produto tem uma garantia do fabricante de 10 anos contra defeitos de fabrico, a partir da data de compra (se comprado na loja) ou data de entrega (se comprado online), sem custo adicional para uso doméstico normal (não profissional ou comercial).

Para apresentar uma reclamação ao abrigo desta garantia, é necessário apresentar a prova de compra (tal como um recibo, uma fatura de compra ou outra prova admissível em conformidade com a lei em vigor). Mantenha o comprovativo de compra num lugar seguro. Para esta garantia se aplicar, o produto comprado tem de ser novo; não se aplica a produtos em segunda mão ou a produtos de exibição. Salvo disposição em contrário na lei em vigor, a garantia de qualquer produto de substituição expira no final do período da garantia do produto original.

Esta garantia cobre defeitos e falhas de produto, desde que o produto tenha sido utilizado para o fim a que se destina e tenha sido sujeito à instalação, limpeza, manutenção e a cuidados de acordo com as informações contidas nestes termos e condições, no manual do utilizador e na prática padrão, desde que a mesma não contrarie o manual de utilizador.

Esta garantia não cobre defeitos e danos causados pelo desgaste normal, nem danos que possam resultar de utilização indevida, instalação ou montagem incorreta, negligência, acidentes, utilizações indevidas ou modificações do produto. Salvo disposição em contrário na lei em vigor, esta garantia não abrange, em caso algum, custos auxiliares (expedição, deslocação, custos de desinstalação e reinstalação, mão-de-obra, etc), ou danos diretos e indiretos.

Se o produto apresentar algum defeito, iremos, dentro de um prazo razoável, substituir ou peças sobressalentes.

A garantia não abrange a quebra das paredes em vidro temperado, quando esta ocorre durante a desembalagem, montagem, ou transporte do produto.

Os direitos no âmbito desta garantia têm força executiva no país onde adquiriu este produto. As questões relativas à garantia devem ser esclarecidas na loja onde adquiriu o produto. A garantia complementa e não afeta os seus direitos legais.

Se adquiriu este produto em Portugal - o distribuidor é responsável por quaisquer defeitos de conformidade do produto de acordo com os termos da lei relativa a garantias (Decreto-Lei N.º 67/2003), aditada pelo Decreto-Lei N.º 84/2008.

**IMPORTANTE -
GUARDE ESTA
INFORMAÇÃO
PARA REFERÊNCIA
FUTURA: LER
CUIDADOSAMENTE**



- EN CAUTION:** Be careful of cutting edges. Wear gloves during installation.
- FR ATTENTION:** Faites attention aux bords coupants. Portez des gants lors de l'installation.
- PL PRZESTROGA:** Uwazac na ostrza tnace. Nosic rekawice podczas montazu.
- RO ATENȚIE:** Aveți grijă la marginile ascușite. Purtați manusi în timpul instalării.
- ES PRECAUCIÓN:** Tenga cuidado con los filos cortantes. Use guantes durante la instalación.
- PT ATENÇÃO:** Tenha cuidado com arestas afiadas. Use luvas durante a instalação.

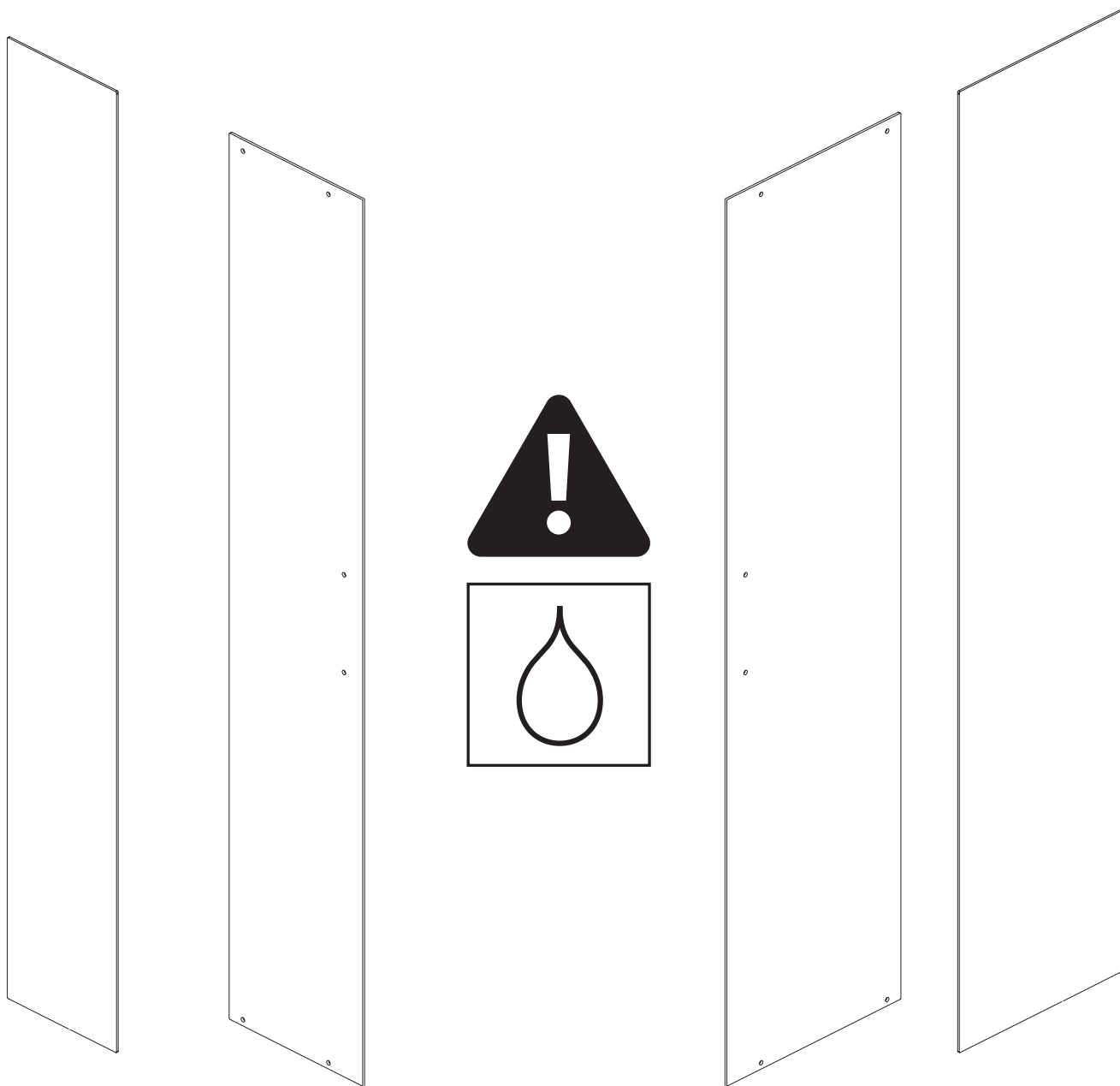

- EN NOTE:** Ensure that the sides of the glass panels with the Easy Clean treatment logo are positioned facing inward.
- FR REMARQUE :** Assurez-vous que les faces des panneaux en verre avec le logo nettoyage facile sont positionnées face vers l'intérieur.
- PL INFORMACJA:** Upewnij się, że obie strony szyb pokrytych powłoką "Easy Celan" Są skierowane do wewnątrz.
- RO NOTĂ:** Asigurați-vă că panourile de sticlă cu fațada tratată cu Easy Clean sunt poziționate înspre interiorul cabinei.
- ES NOTA:** Asegúrese que los lados de los paneles de vidrio con tratamiento de Easy Clean estén colocados hacia el interior.
- PT NOTA:** Certifique-se de que os lados dos painéis de vidro com o tratamento Easy Clean estão voltados para dentro.

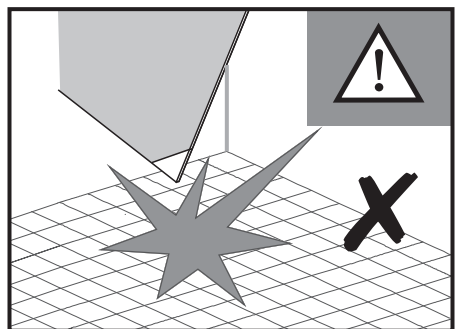
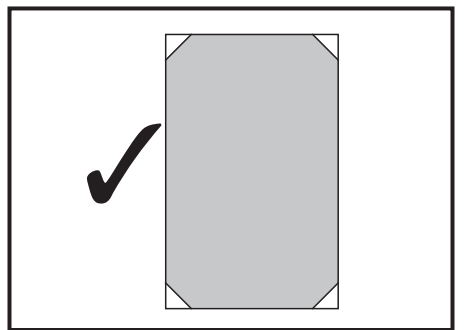
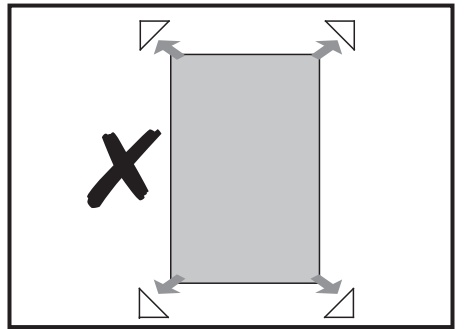
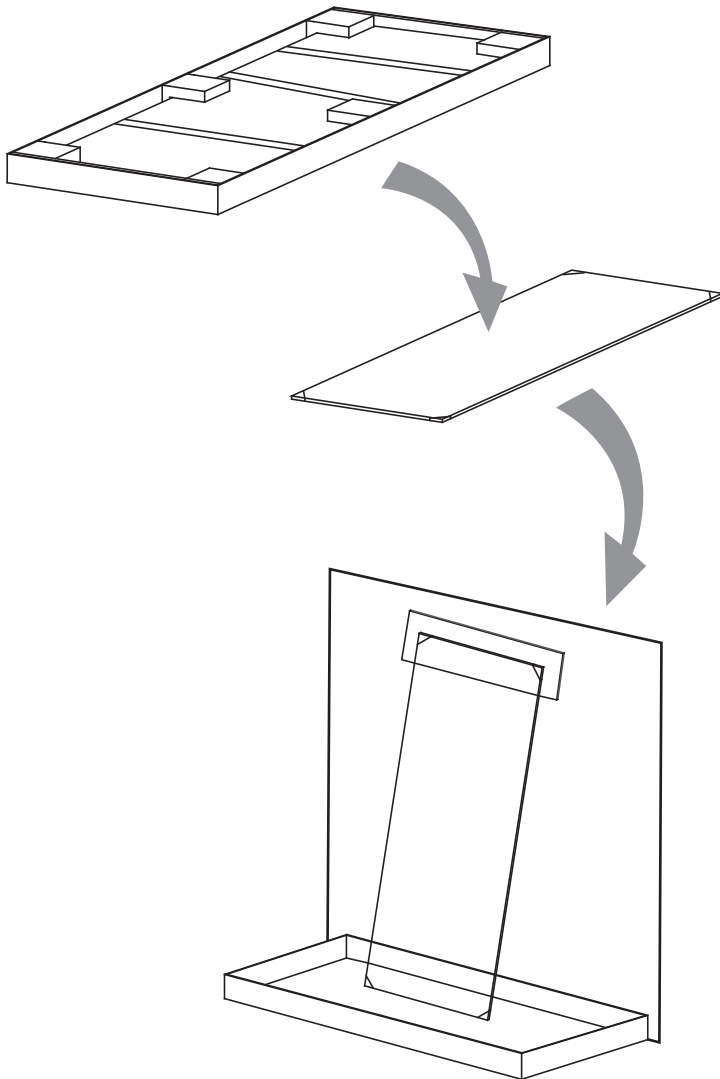
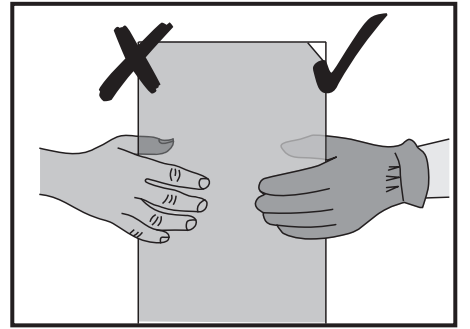
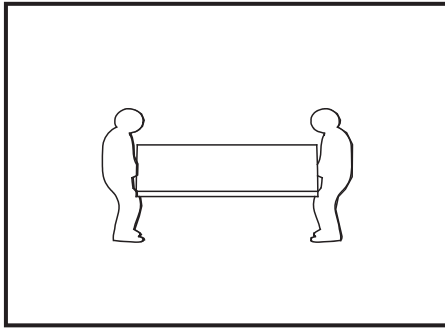
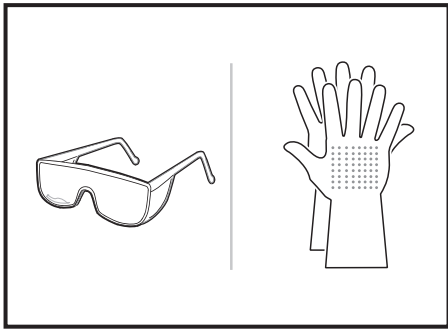
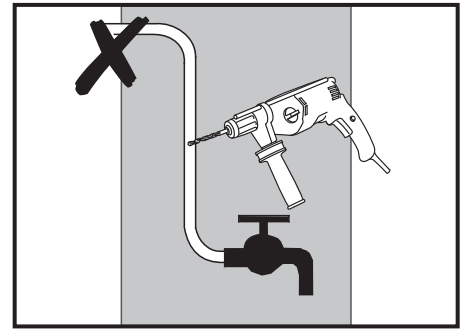
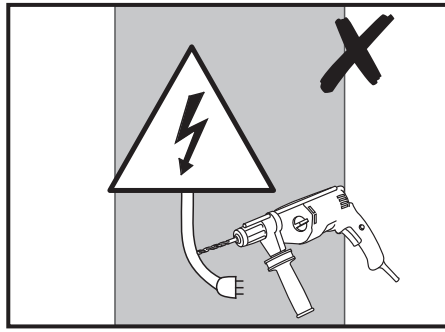
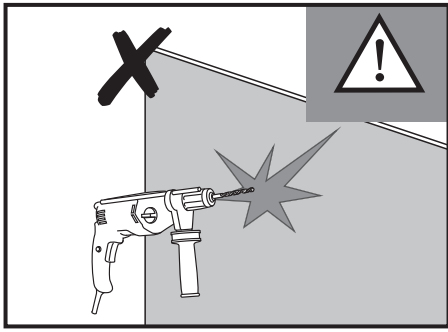

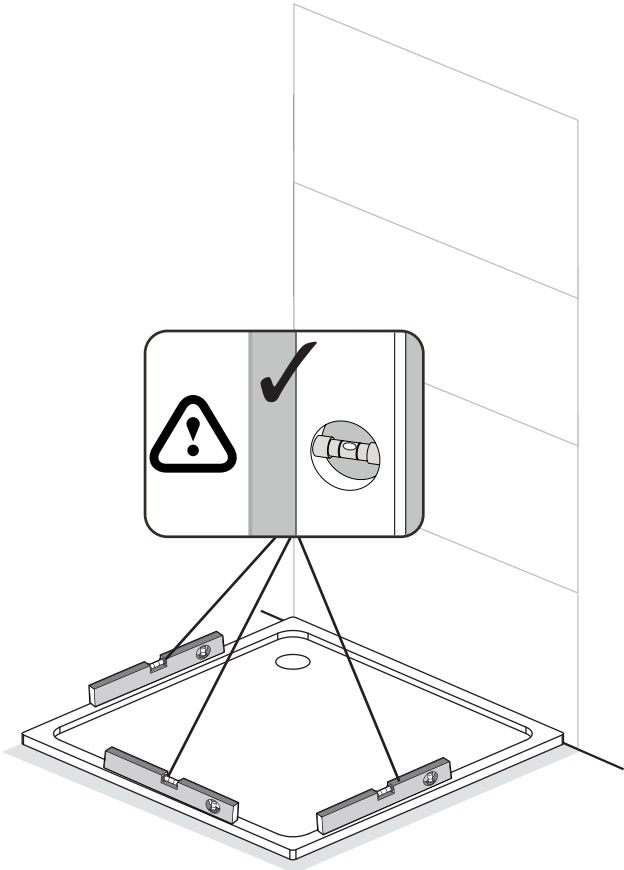
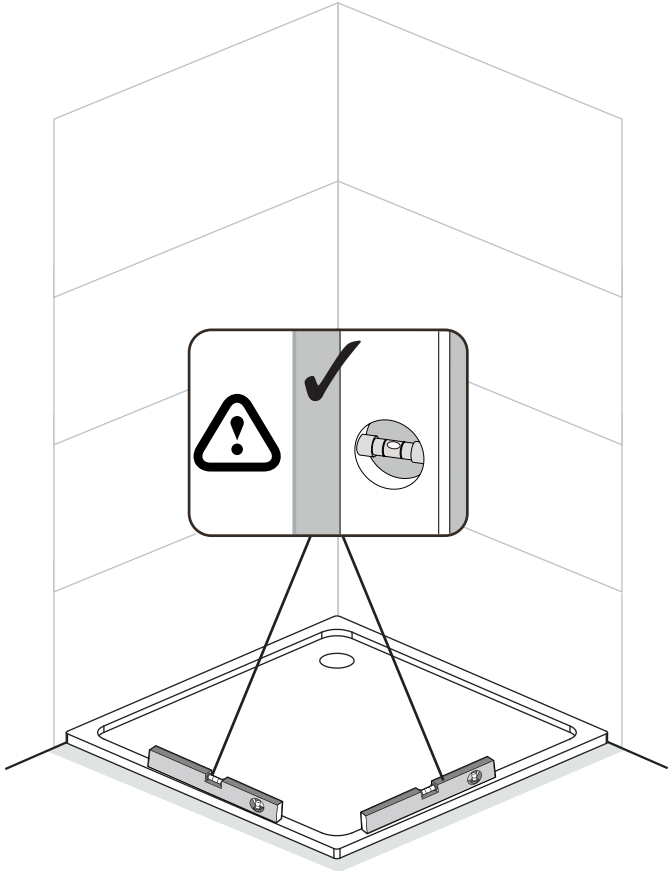

A1

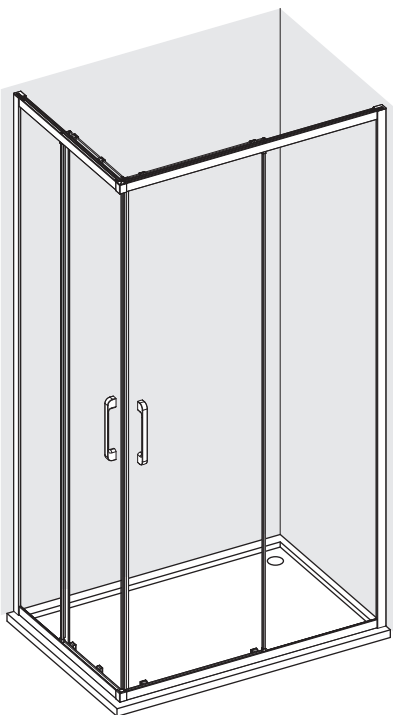

P20~P35

B1

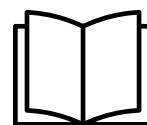
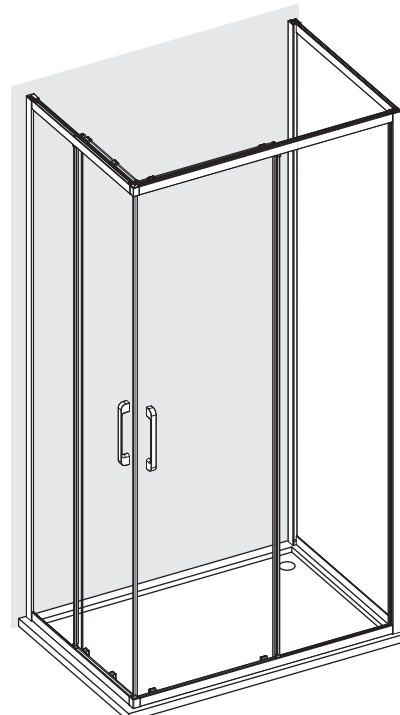

P36~P54

A2

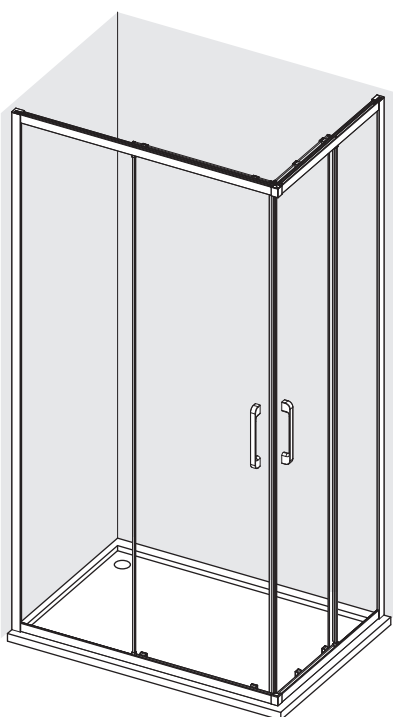

P55~P70

B2

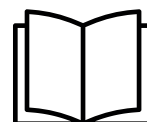
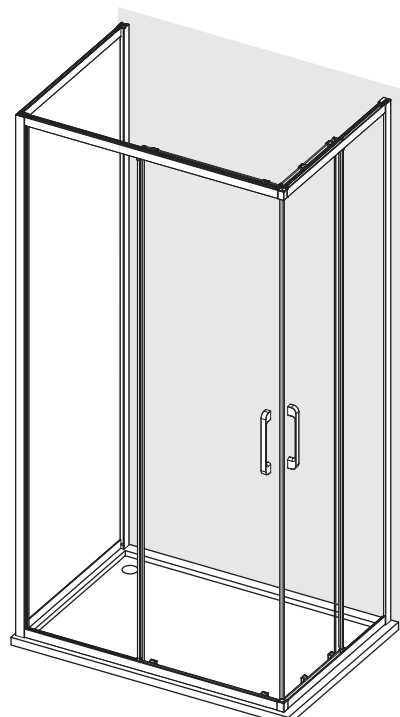

P71~P89

1A

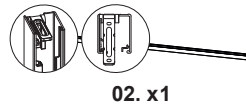
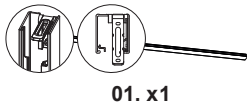
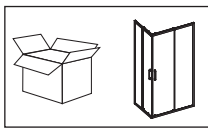

A1



| SIZE (mm) | A(mm) | B(mm) |
|-----------|---------|-----------|
| 700×900 | 675-695 | 875-895 |
| 700×1000 | | 975-995 |
| 700×1200 | | 1175-1195 |

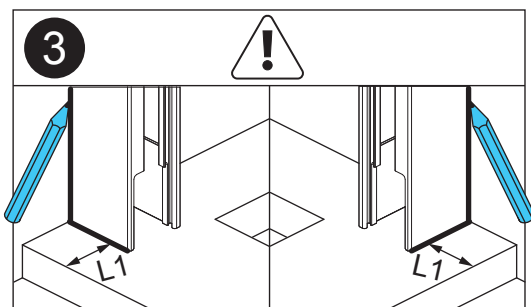
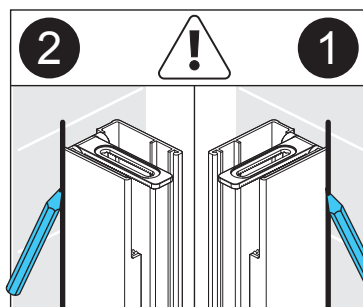
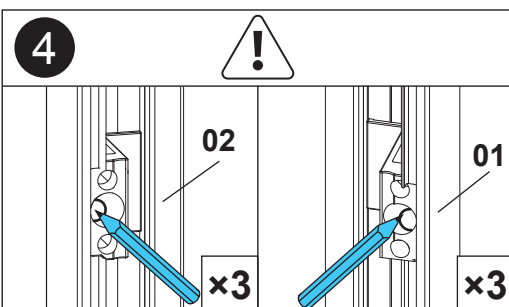
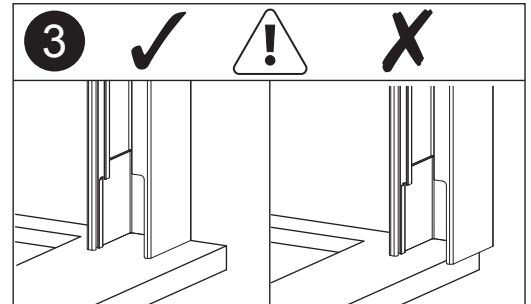
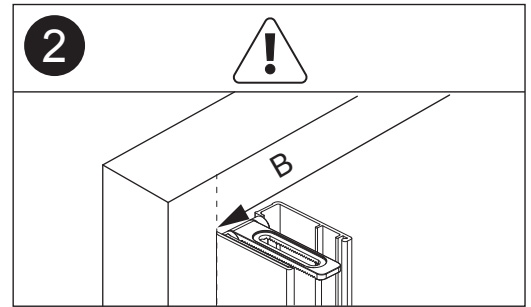
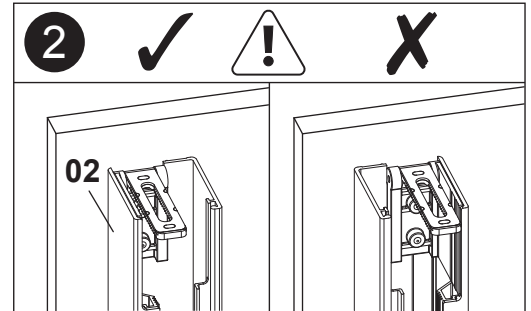
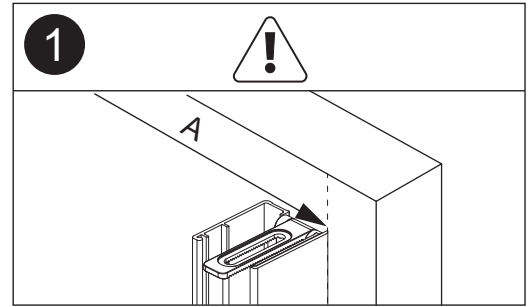
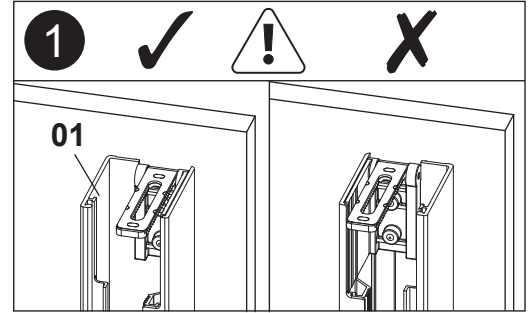
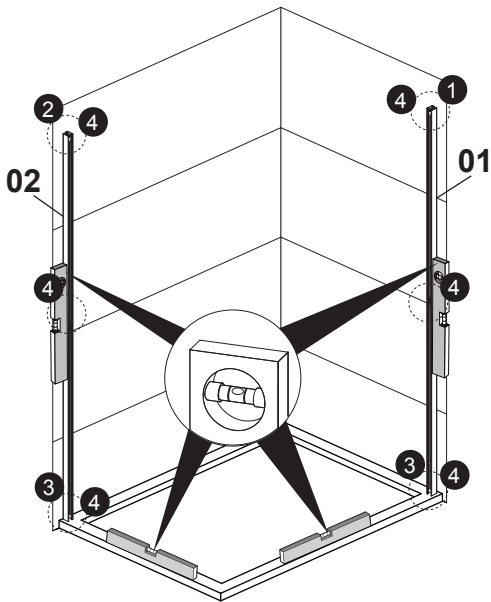
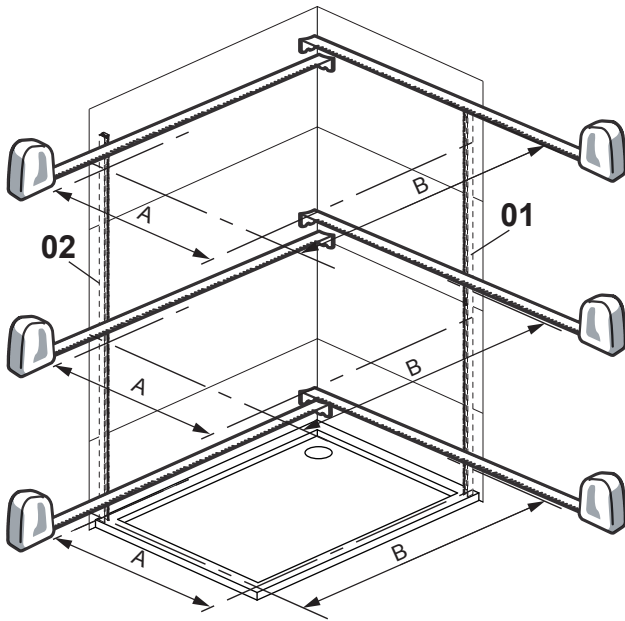

2A

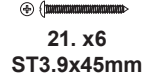
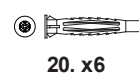
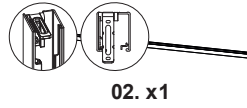
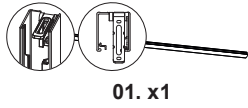
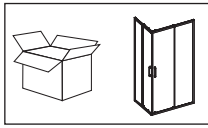

A1

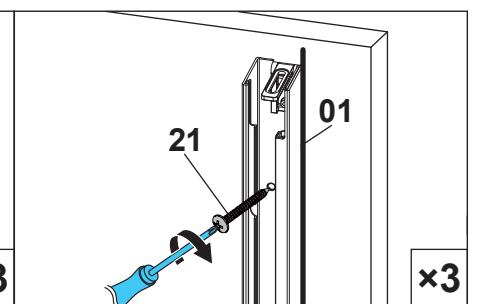
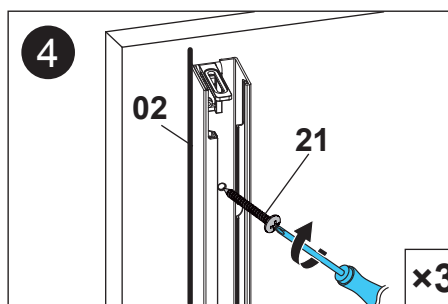
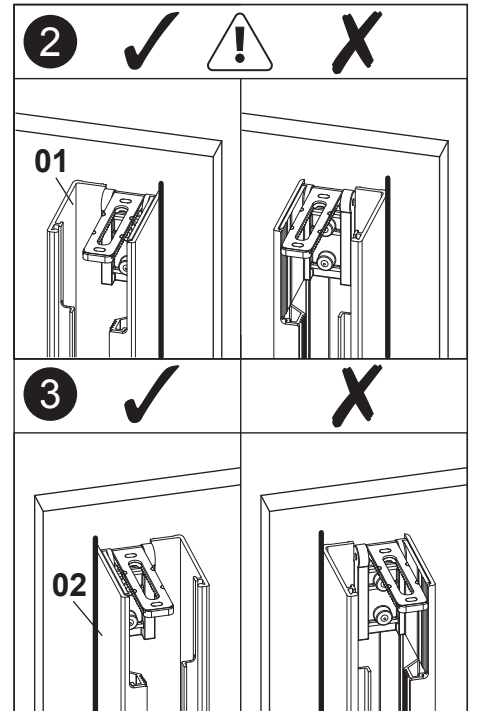
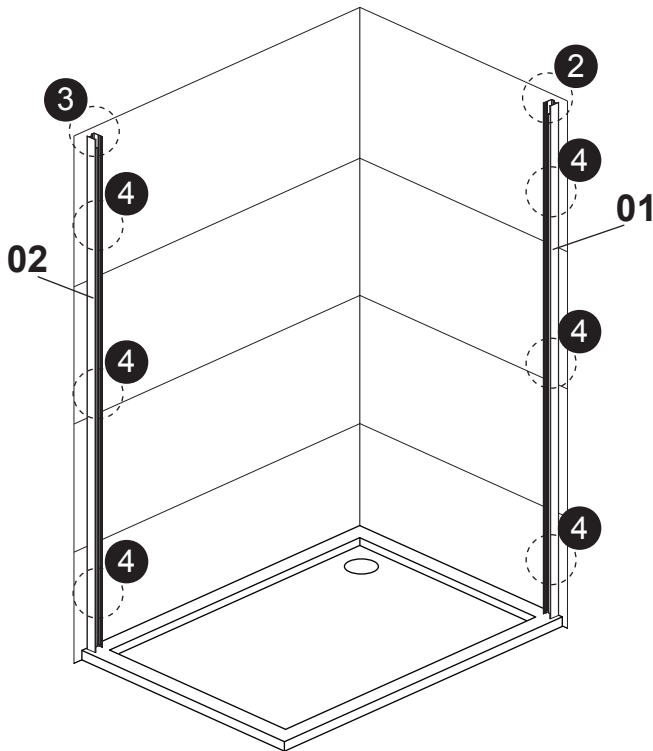
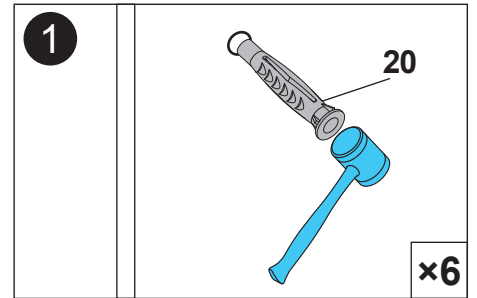
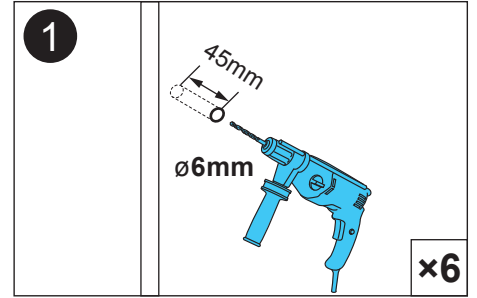
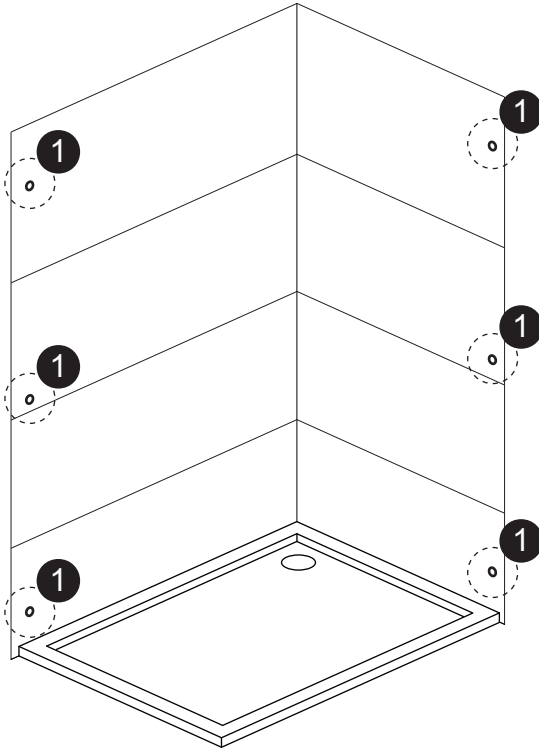

3A

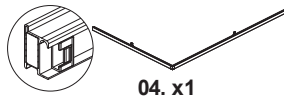
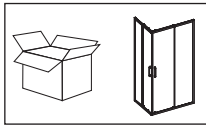

04. x1

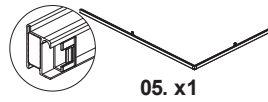

05. x1

A1

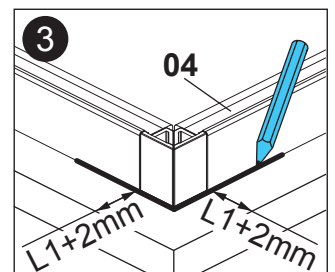
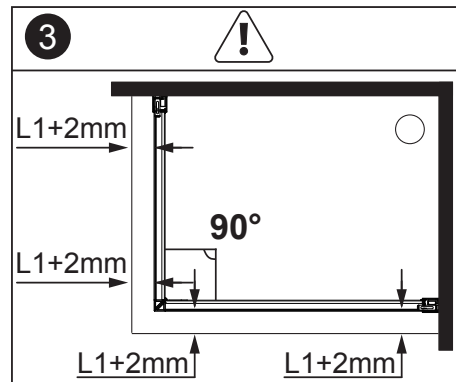
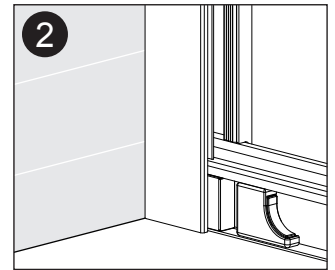
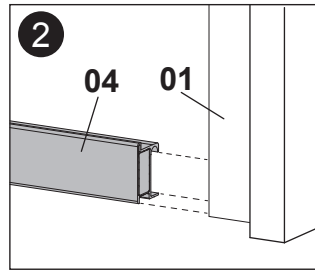
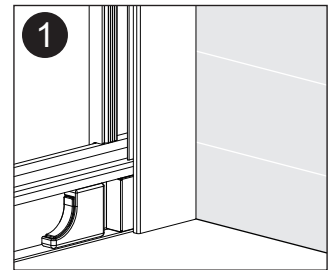
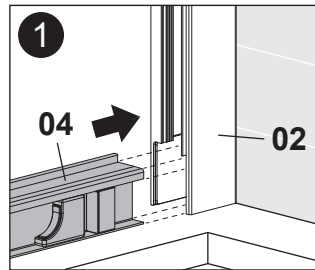
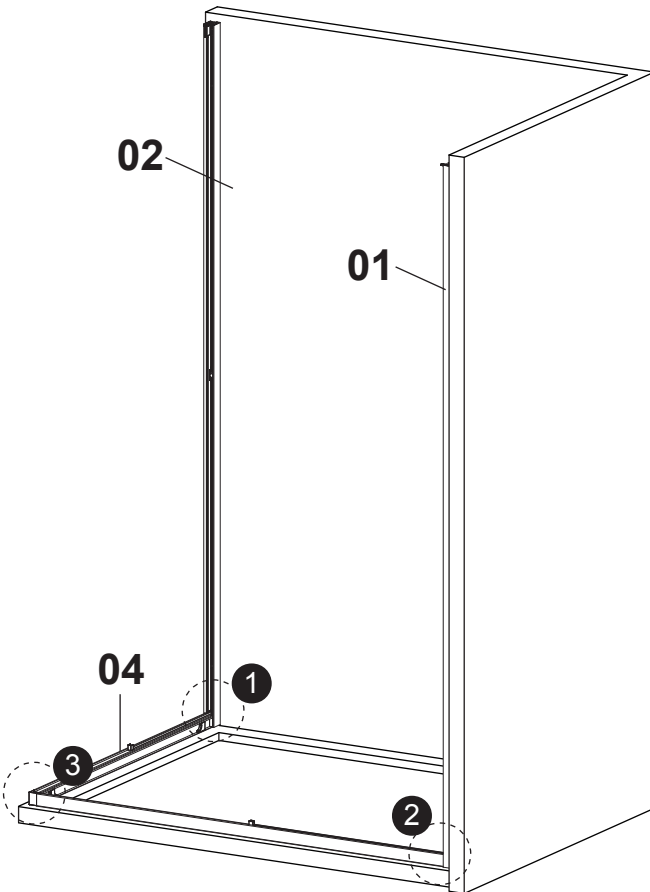
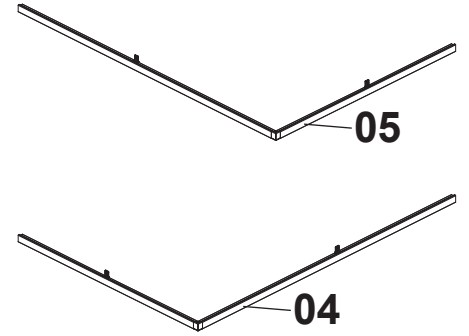
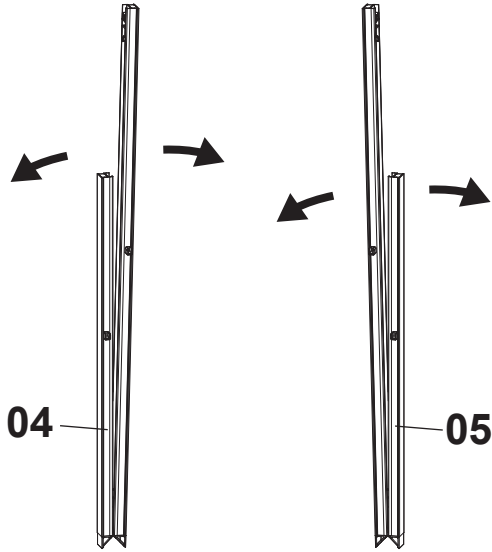

4A

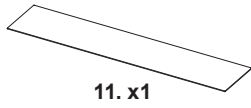
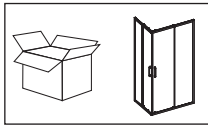

11. x1

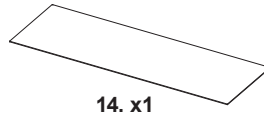

14. x1



50-1. x2



50-2. x2

A1

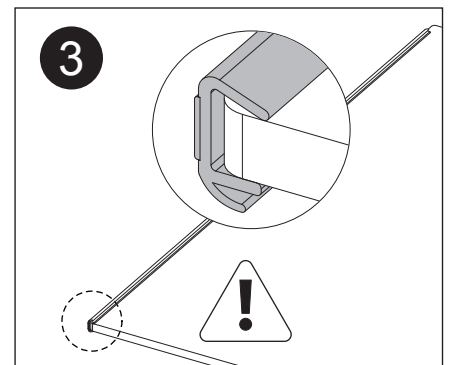
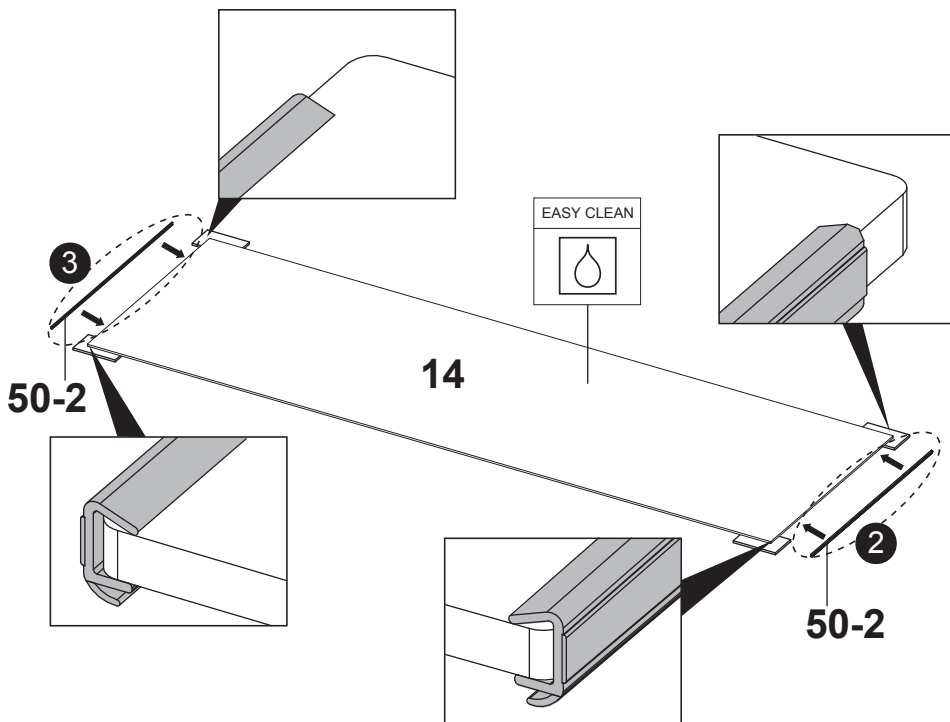
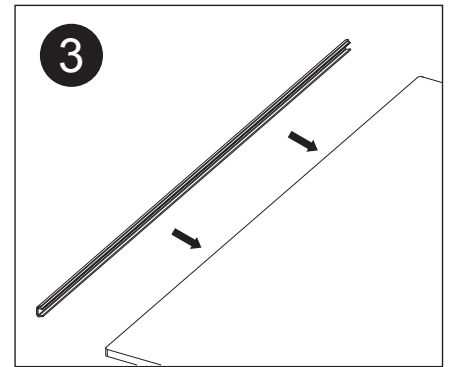
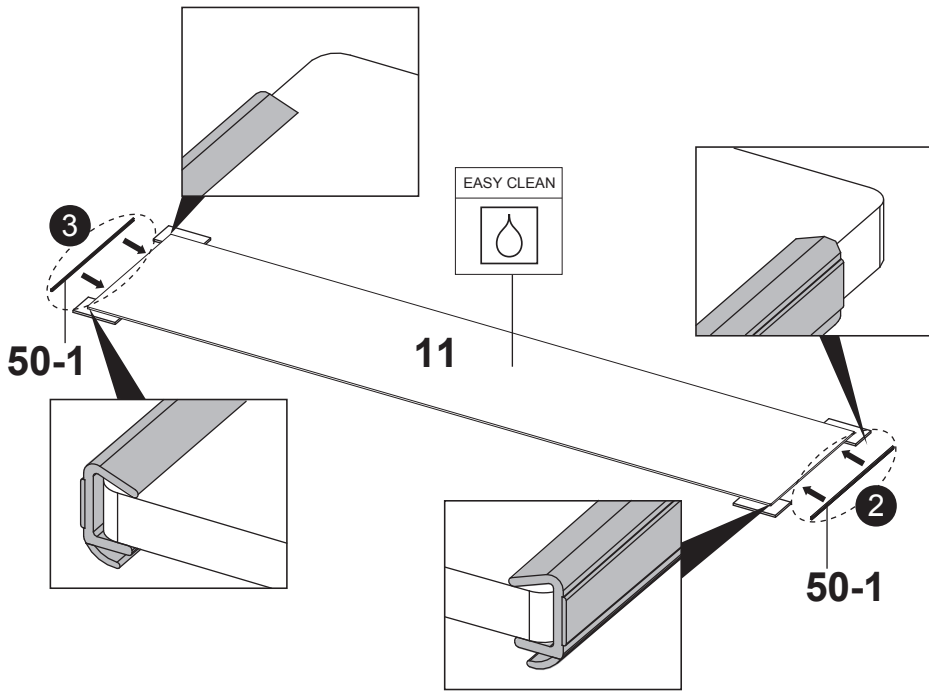
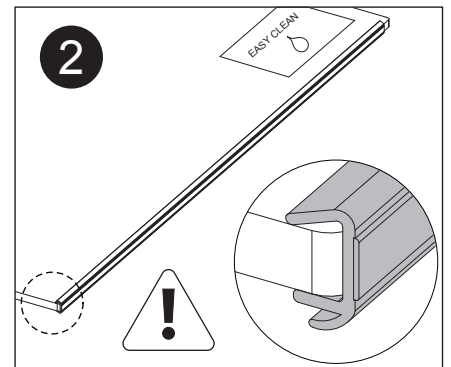
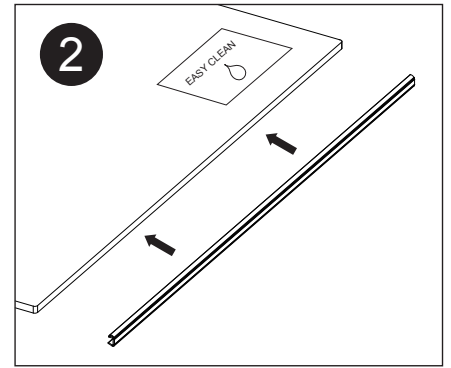
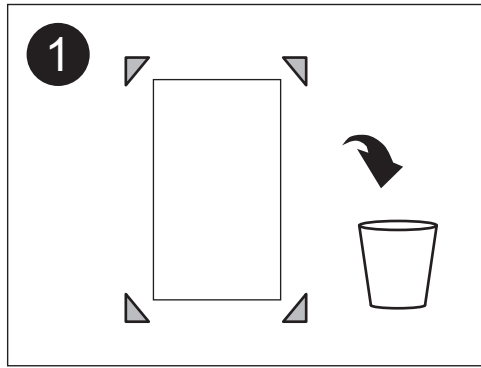

5A

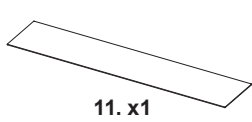
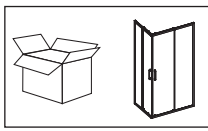

11. x1

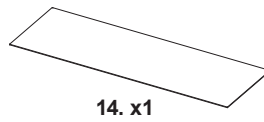

14. x1

A1

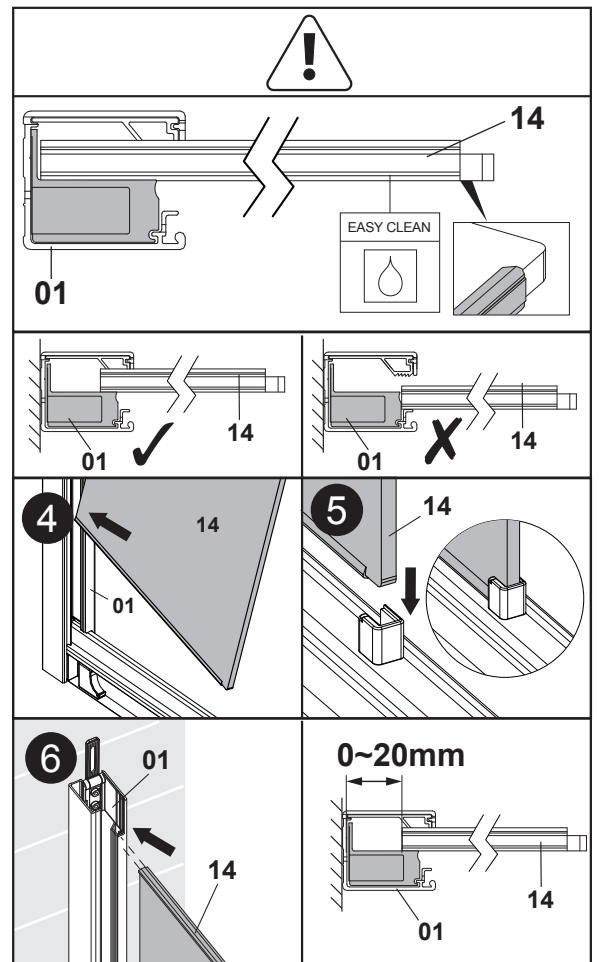
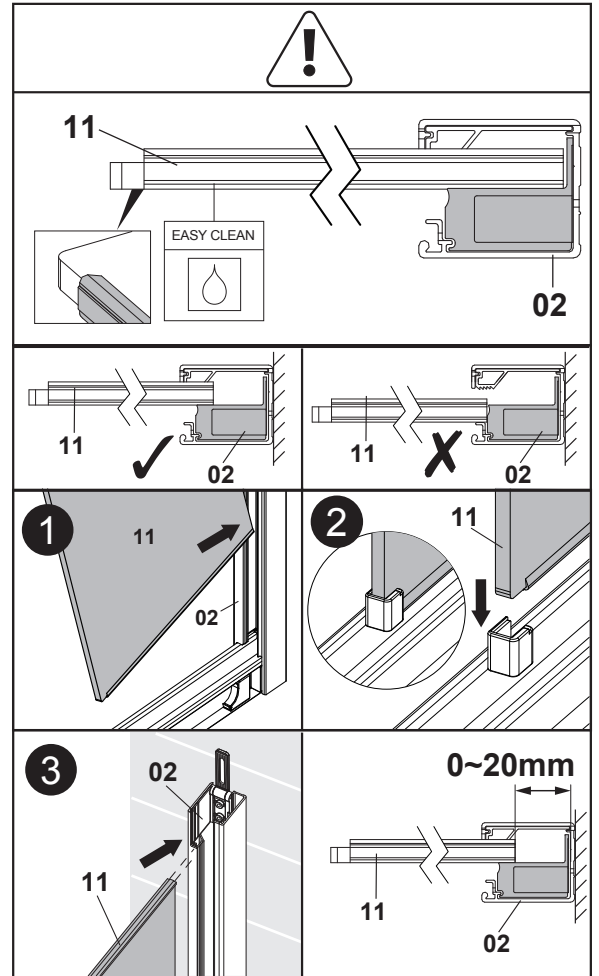
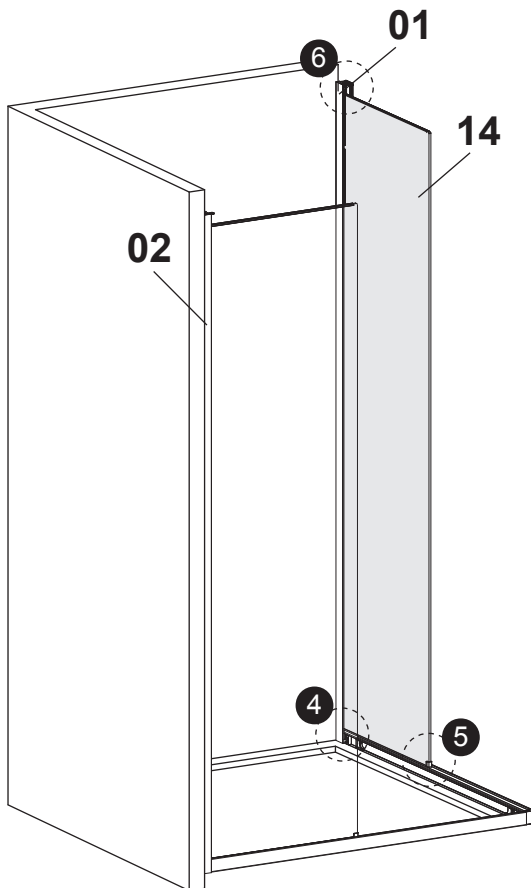
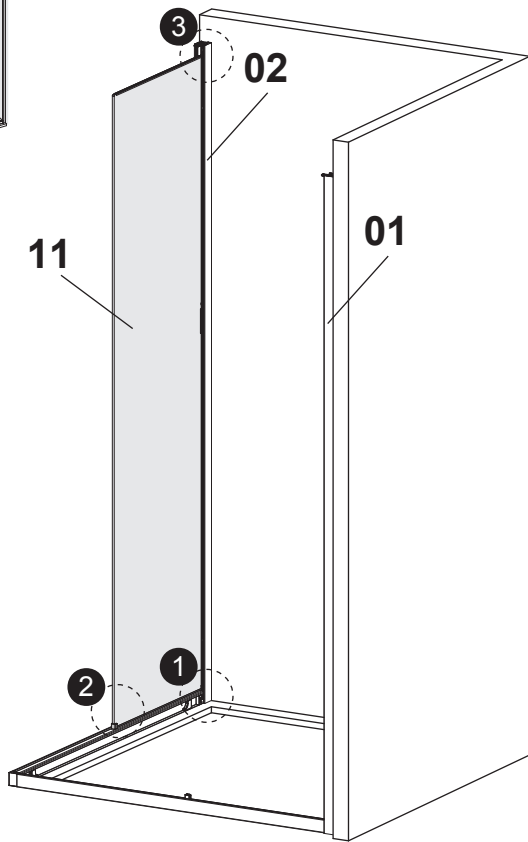
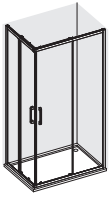

6A

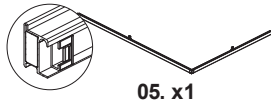
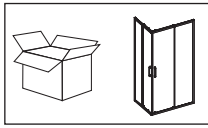

05. x1



22. x2
M4x10mm



29. x1
2.5mm

A1

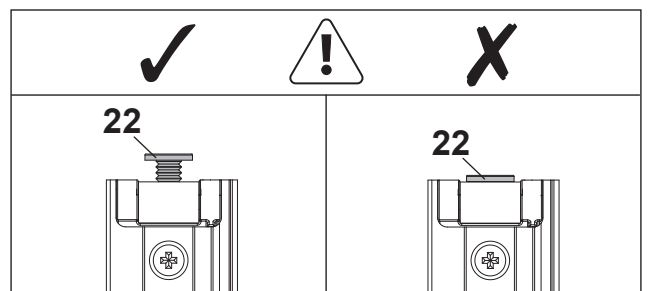
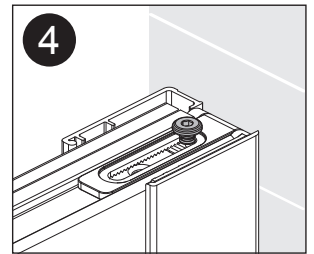
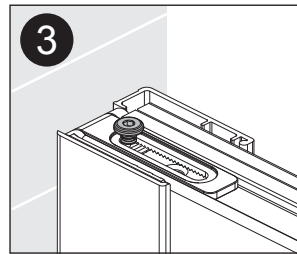
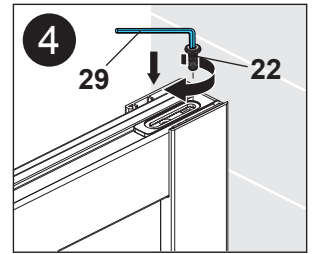
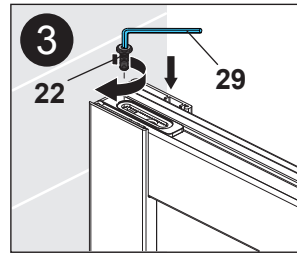
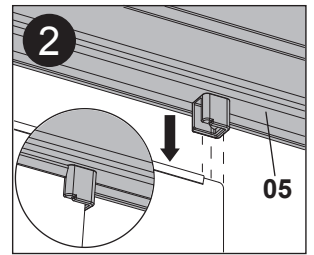
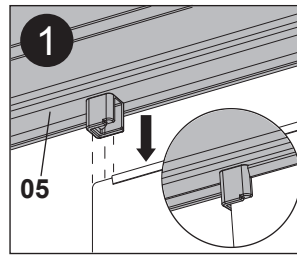
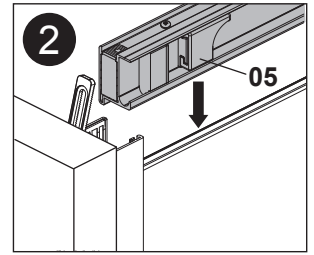
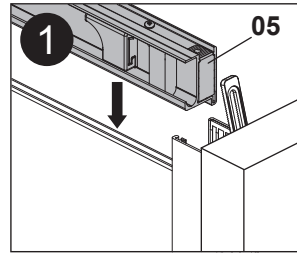
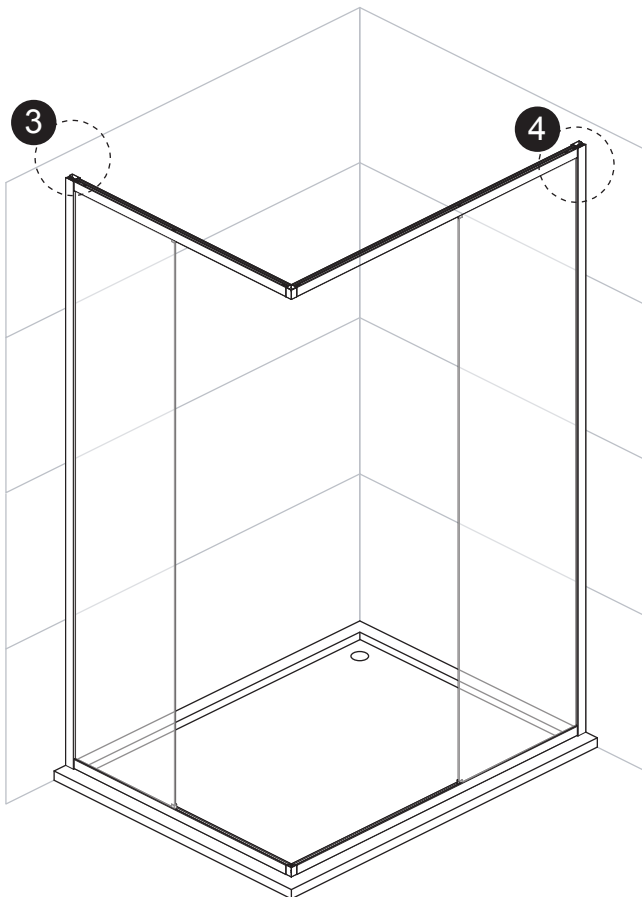
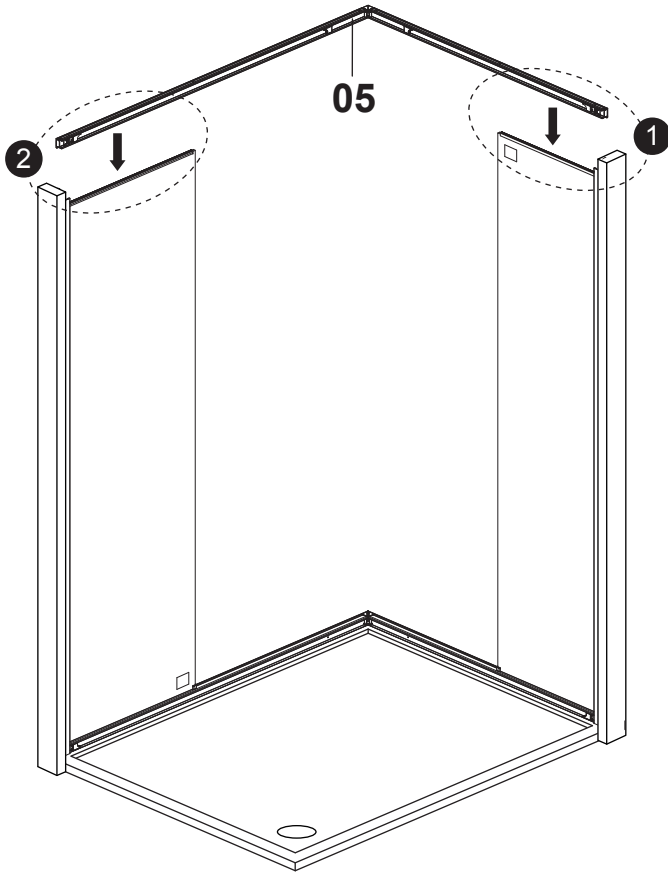

7A

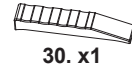
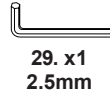
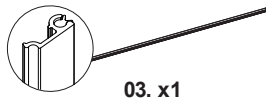
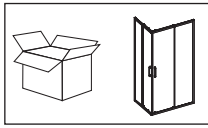

A1

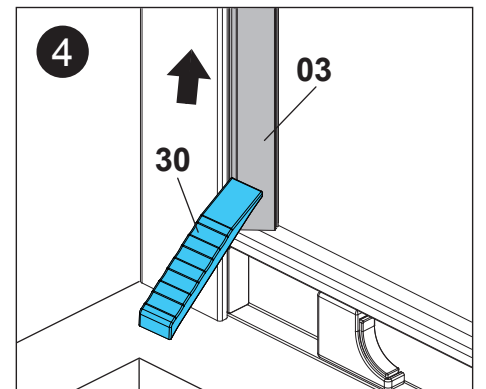
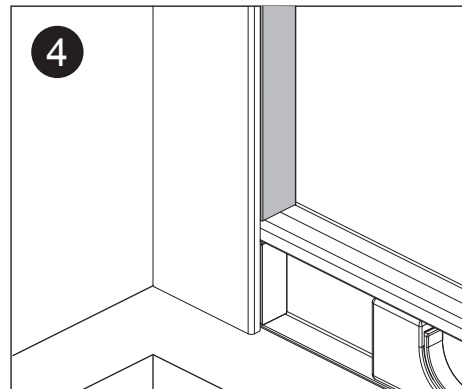
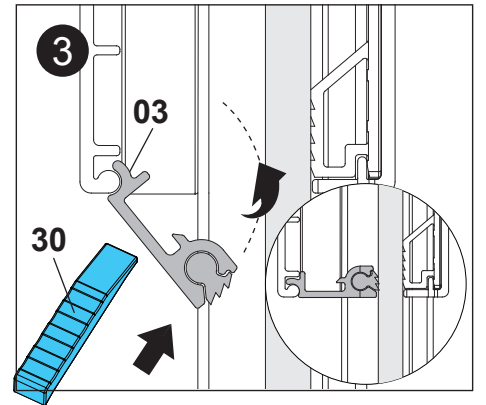
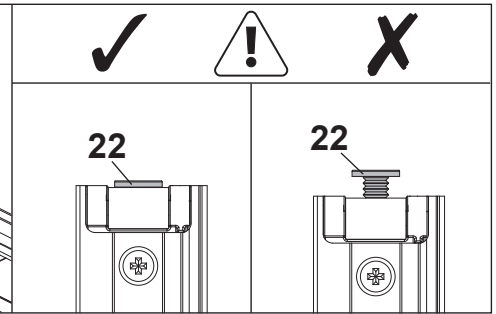
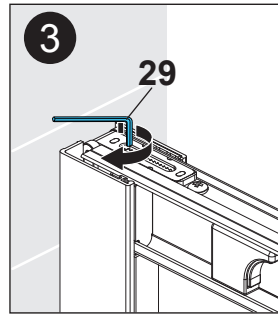
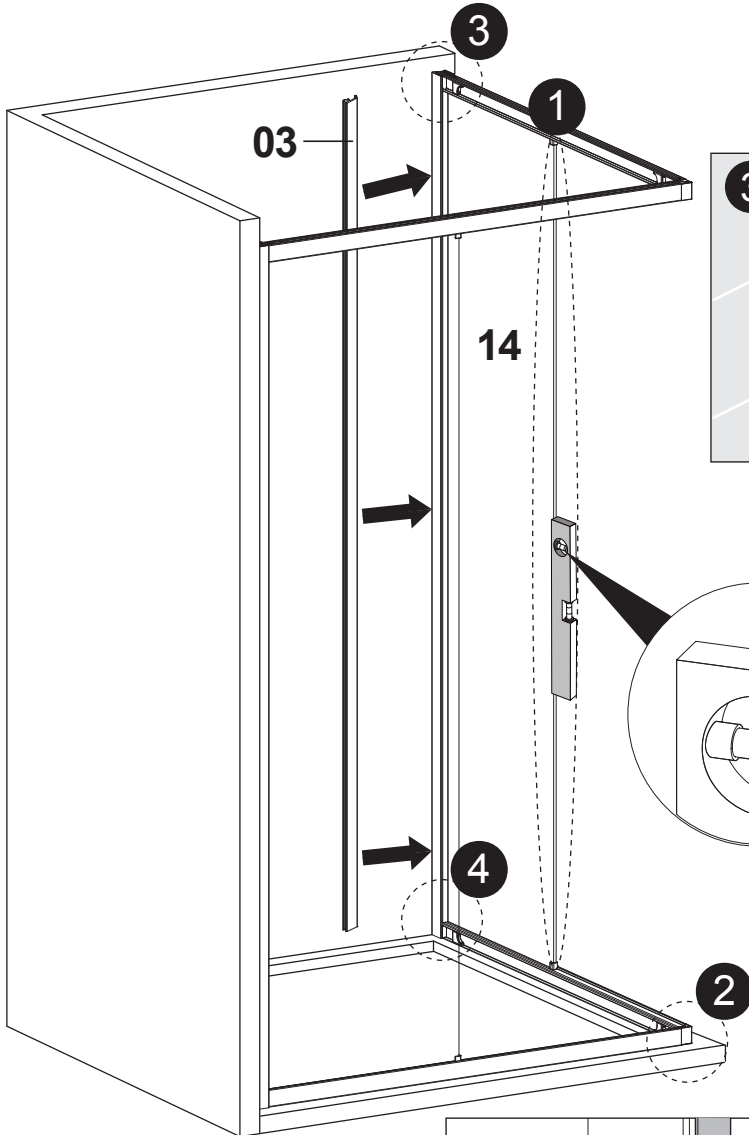
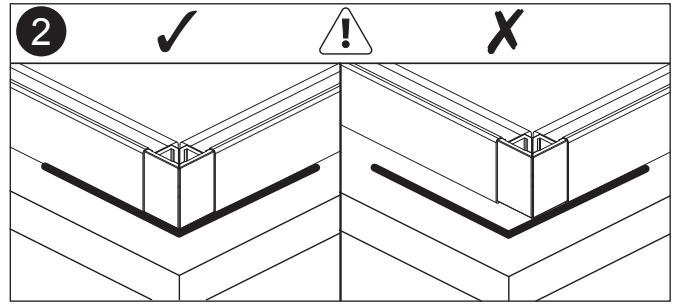
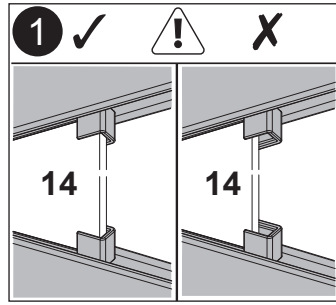

8A

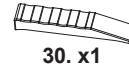
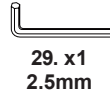
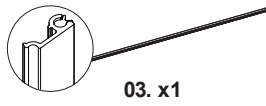
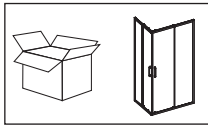

A1

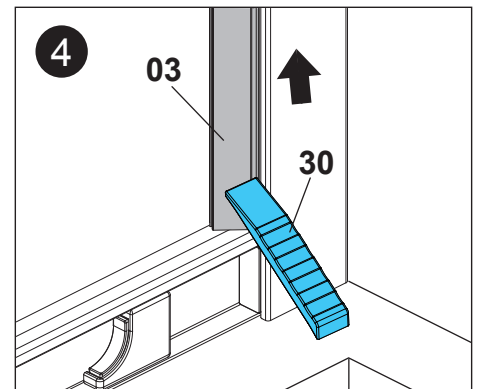
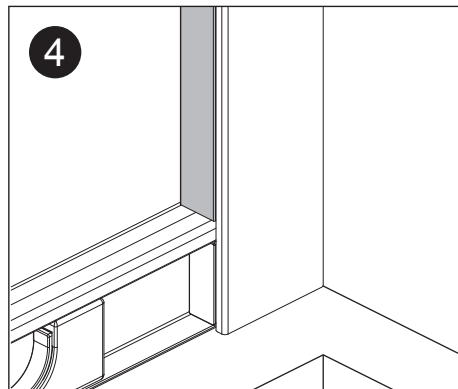
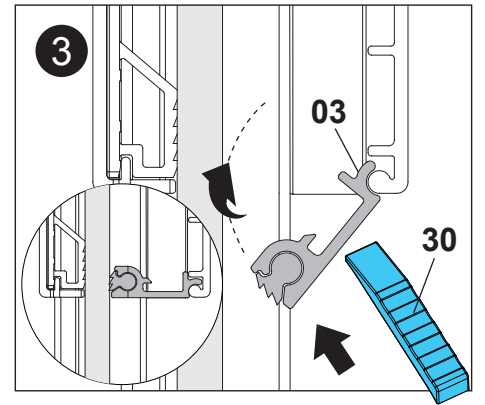
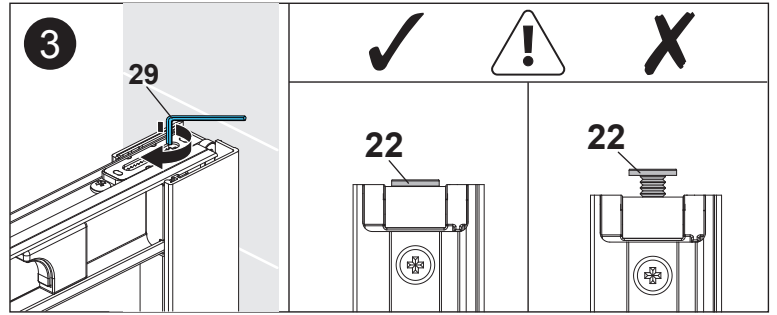
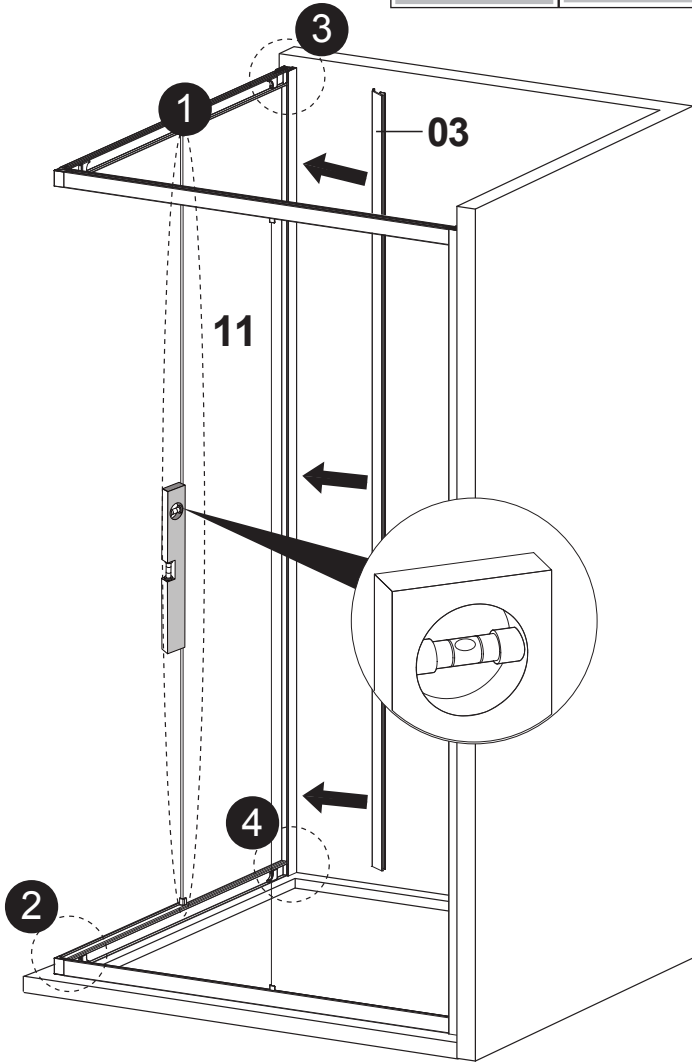
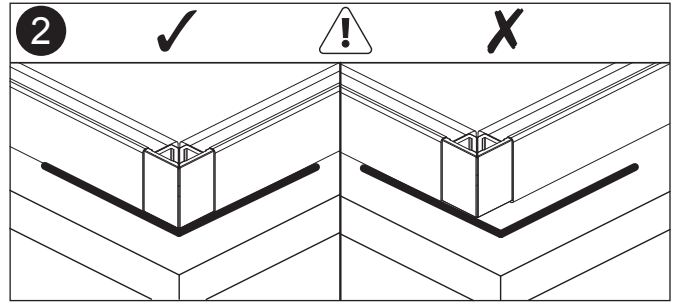
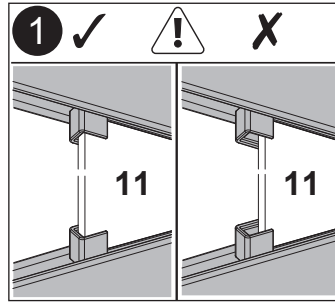

9A

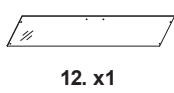
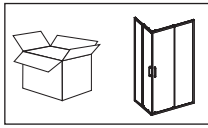

12. x1

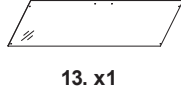

13. x1



26. x4

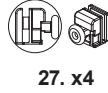

27. x4



29. x1
2.5mm

A1

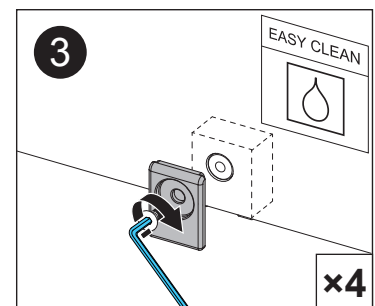
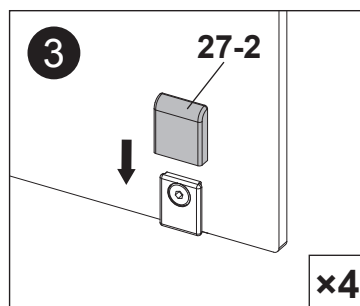
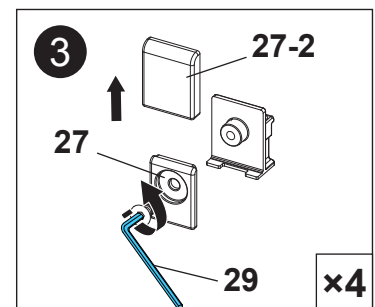
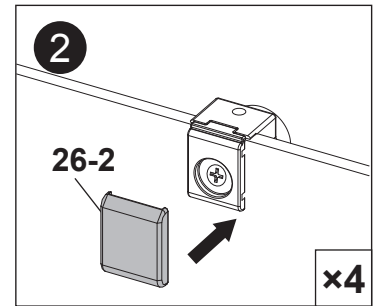
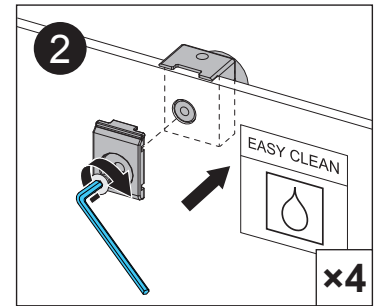
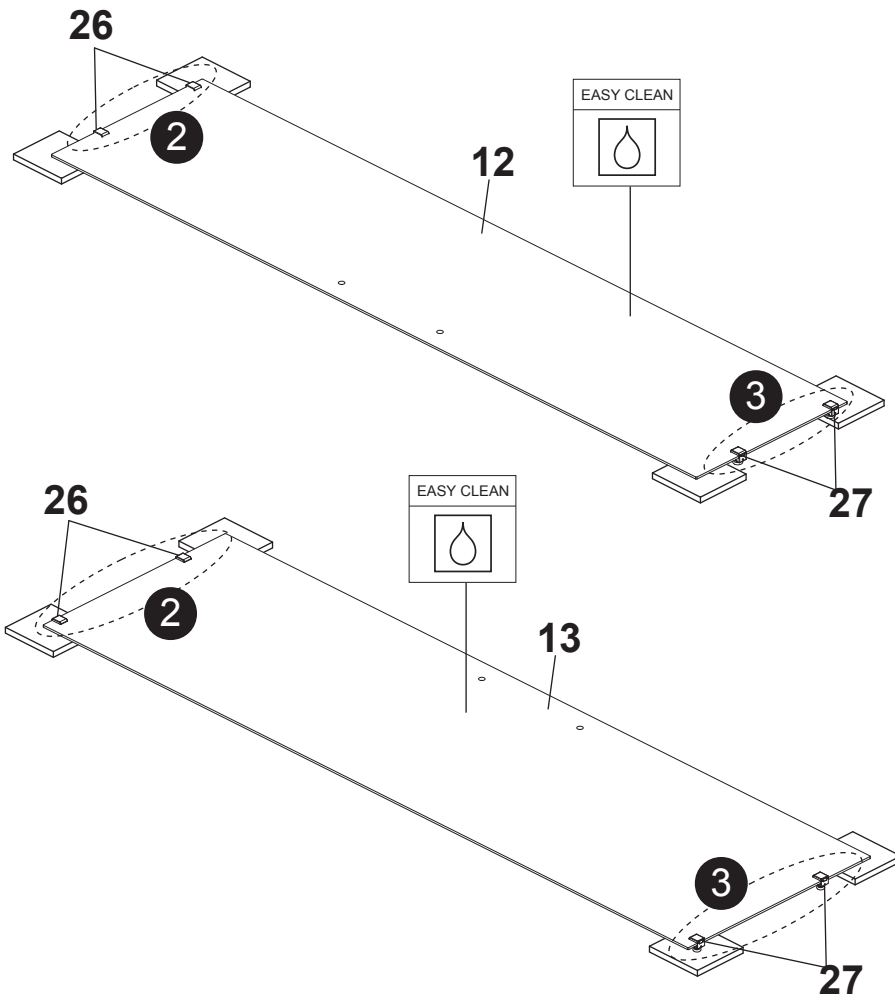
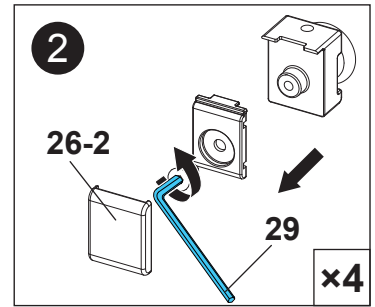
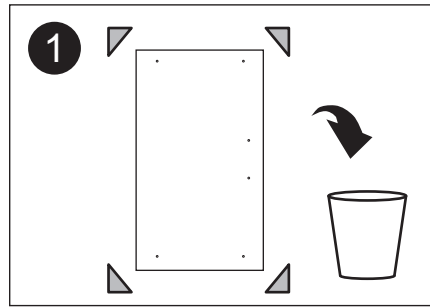
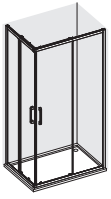

10A

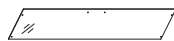
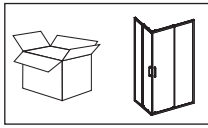

12. x1

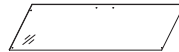

13. x1

A1

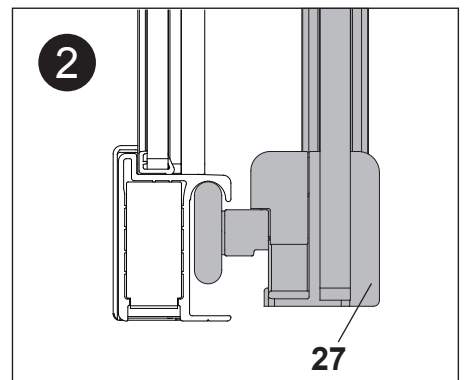
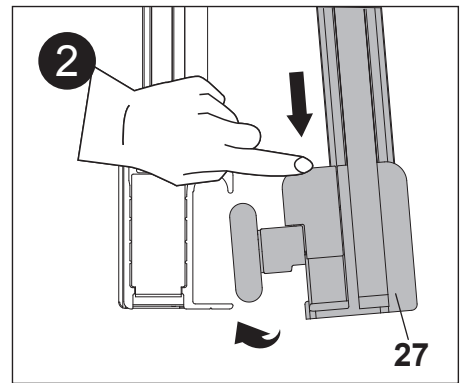
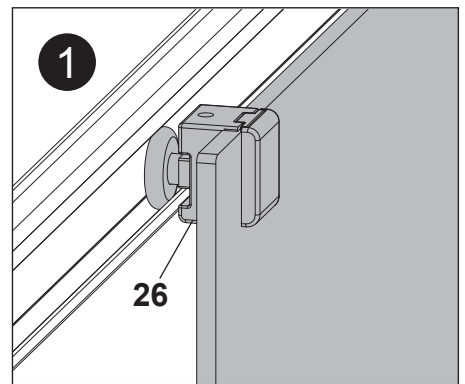
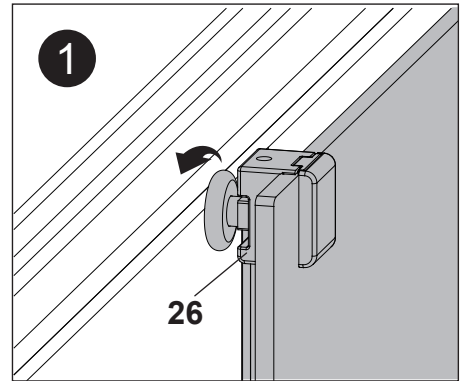
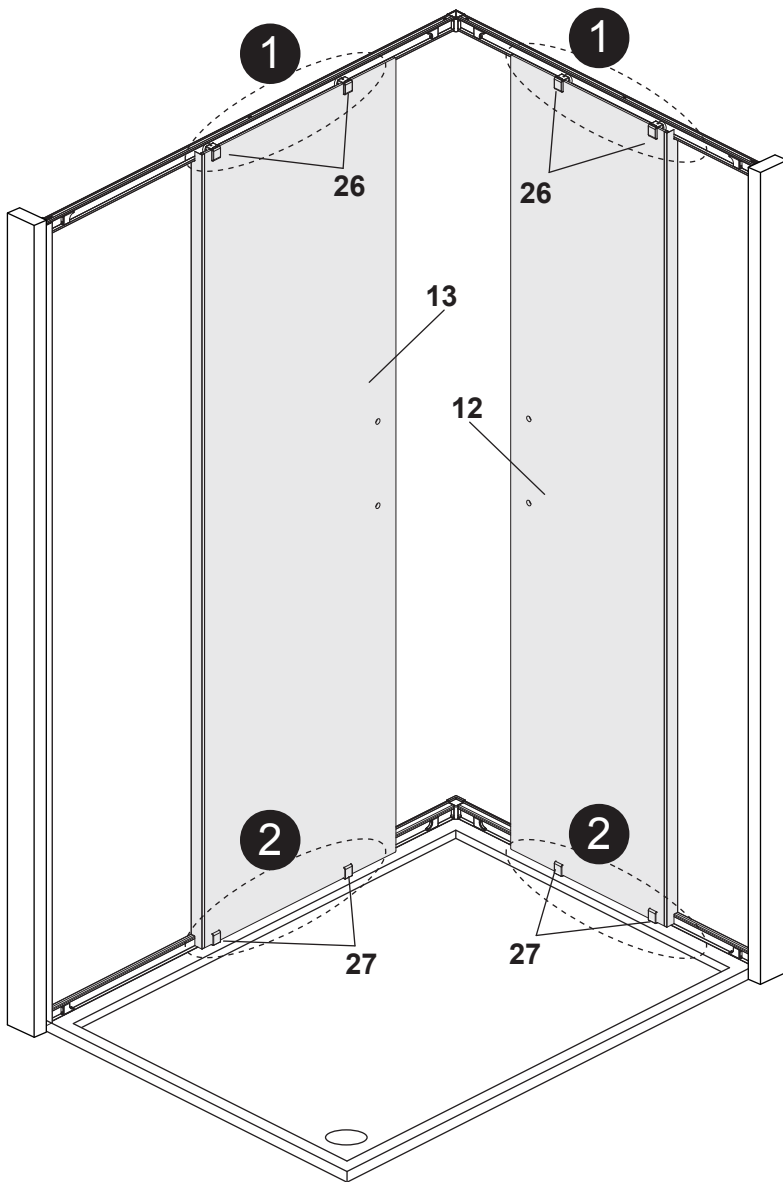

11A

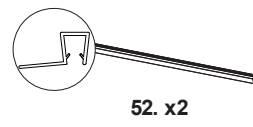
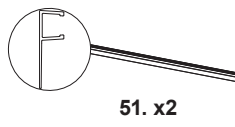
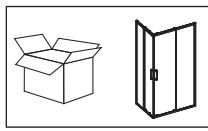

A1

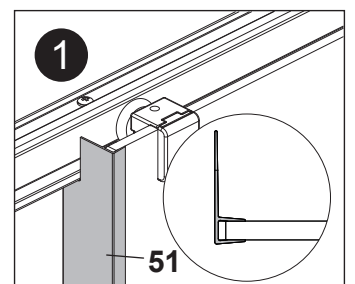
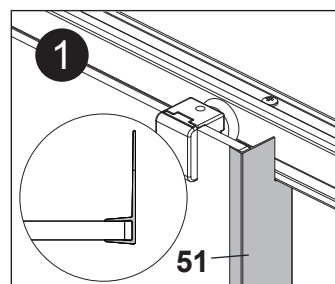
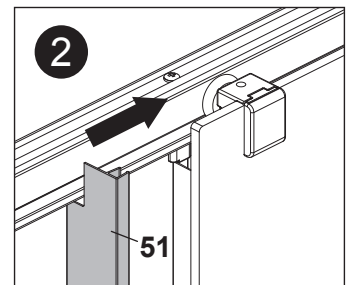
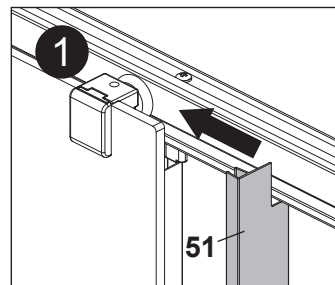
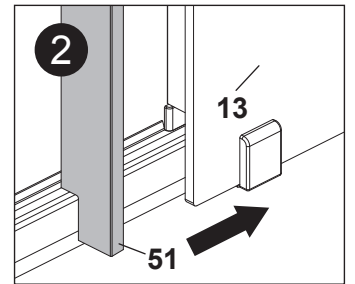
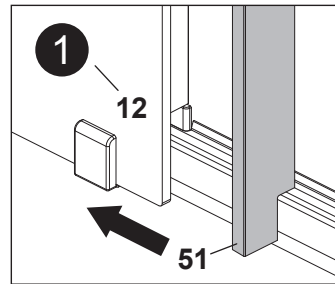
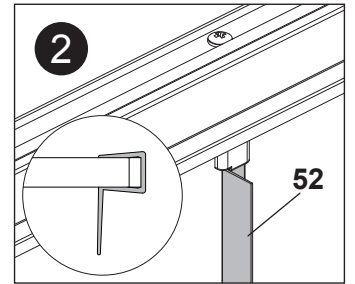
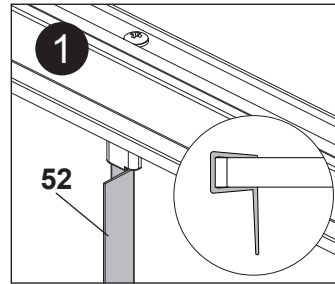
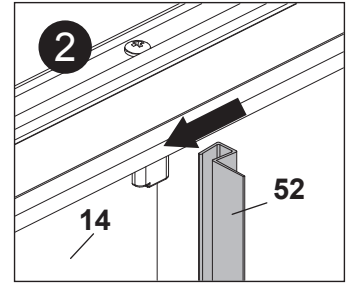
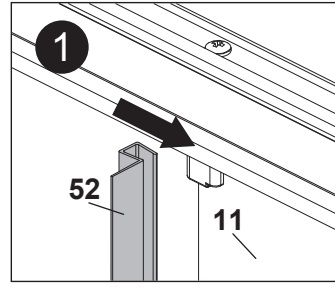
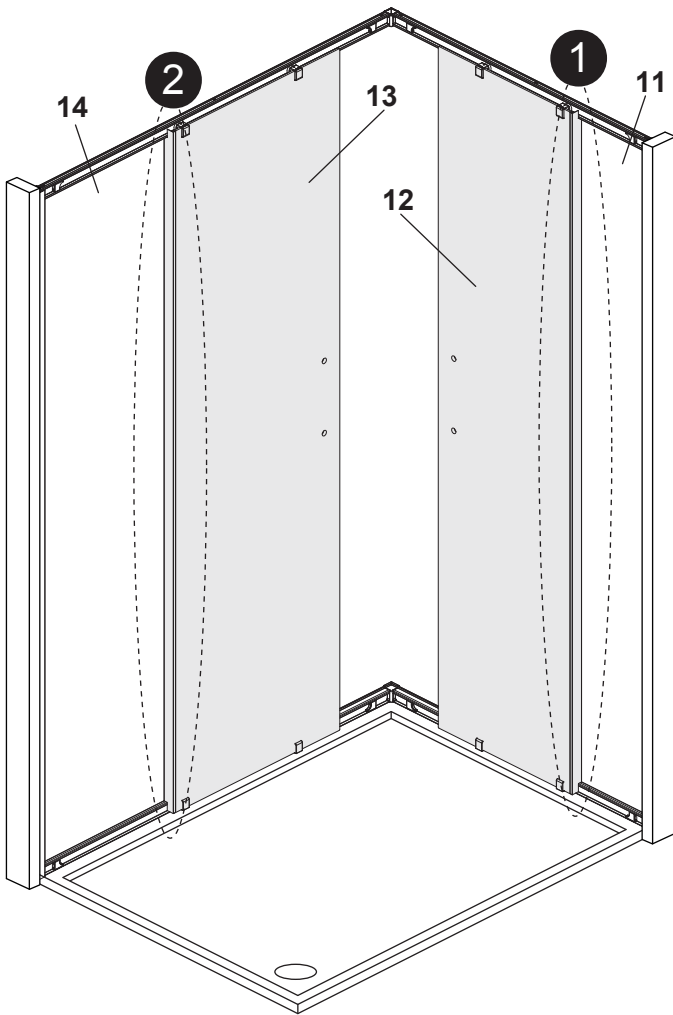
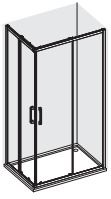

12A

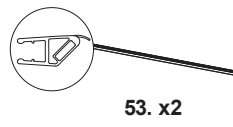
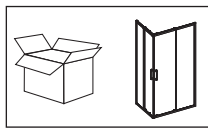

A1

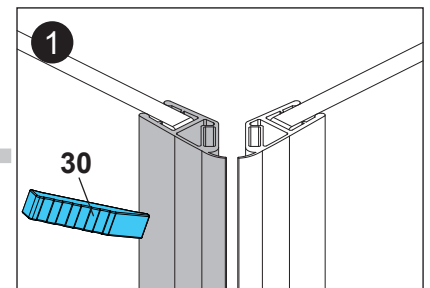
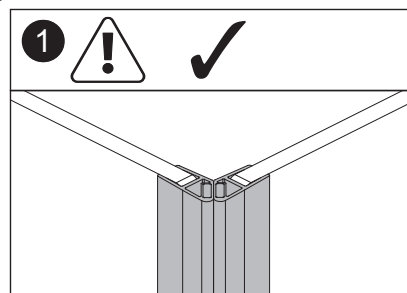
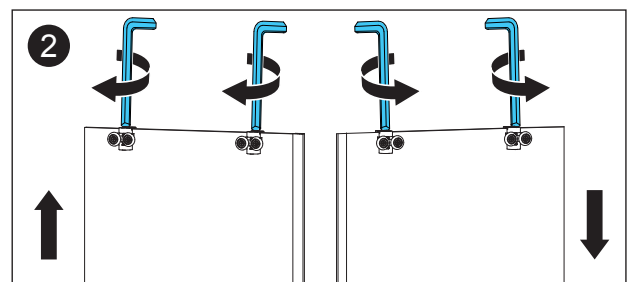
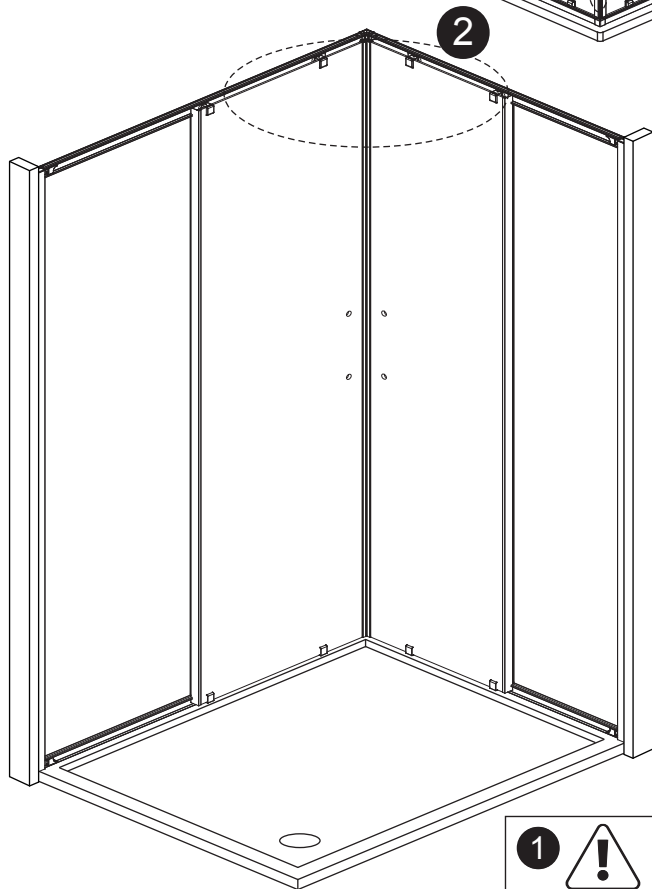
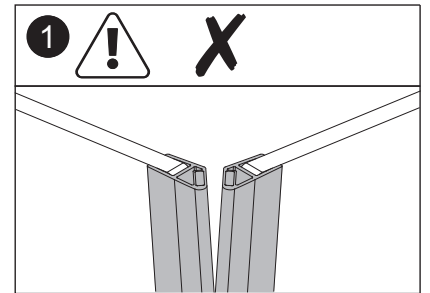
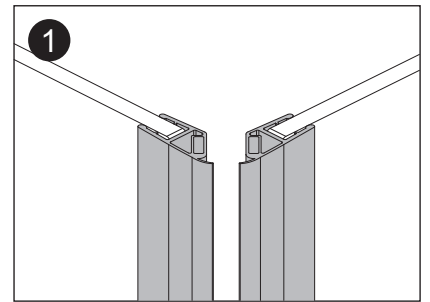
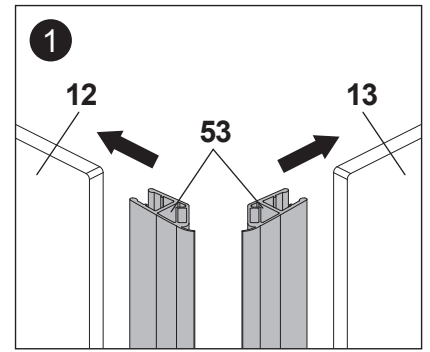
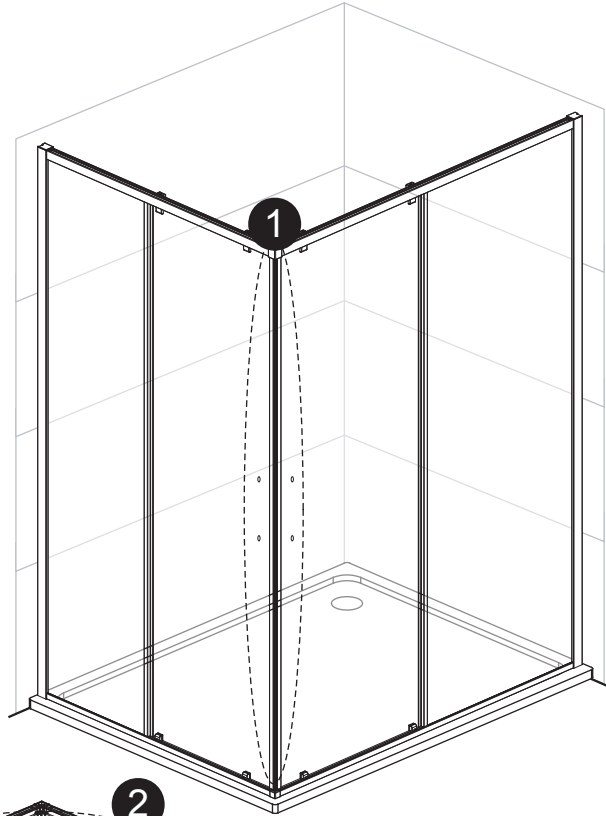

13A

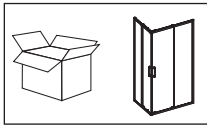

A1

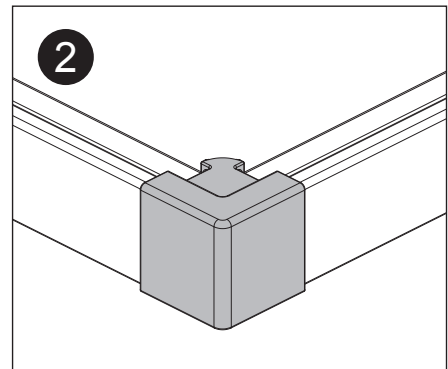
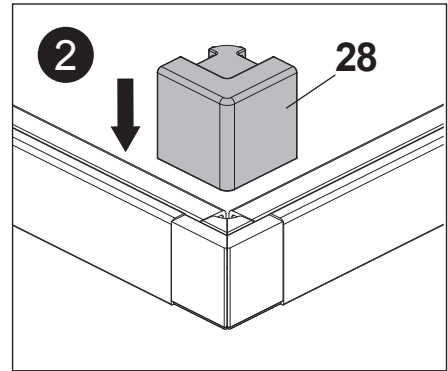
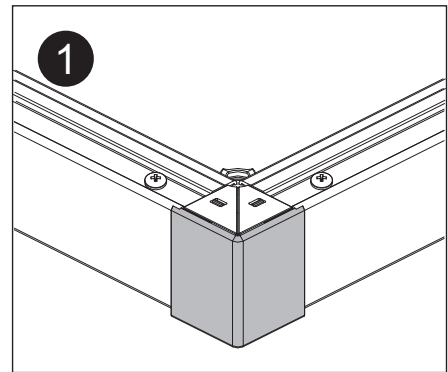
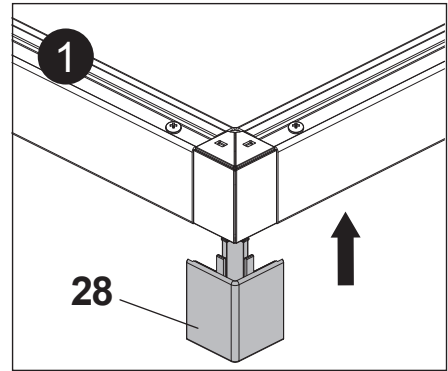
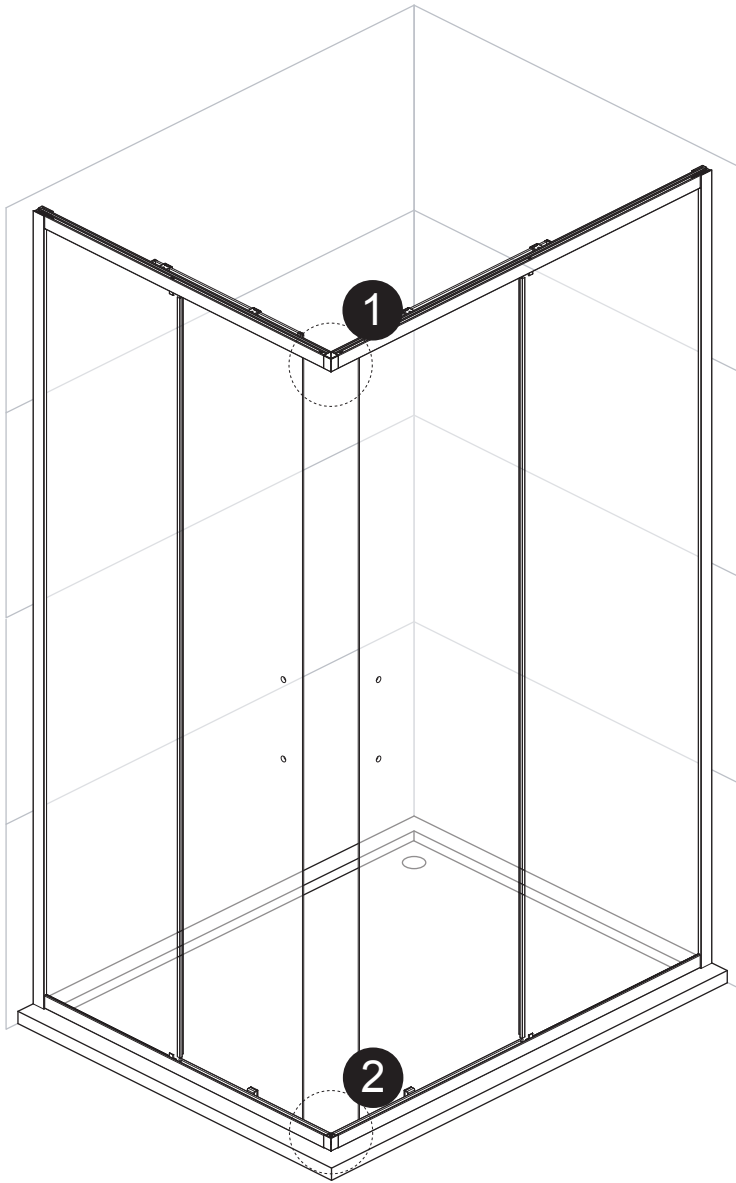

14A

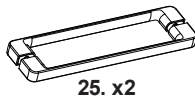
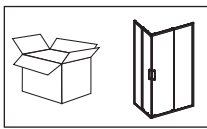

25. x2



29. x1
2.5mm

A1

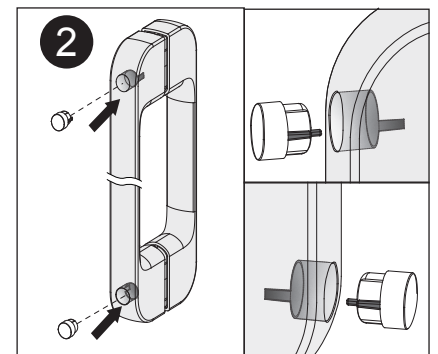
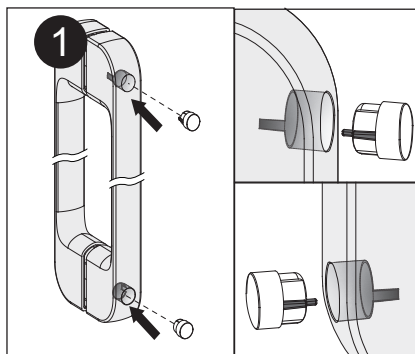
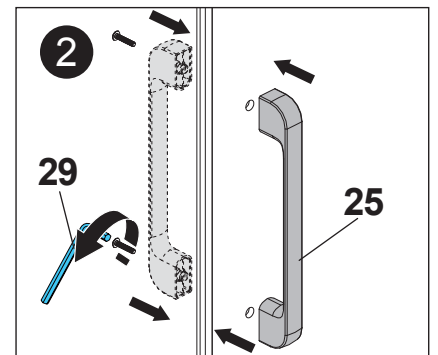
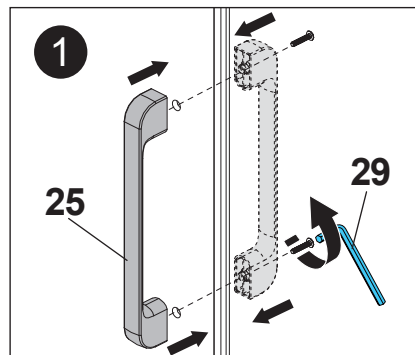
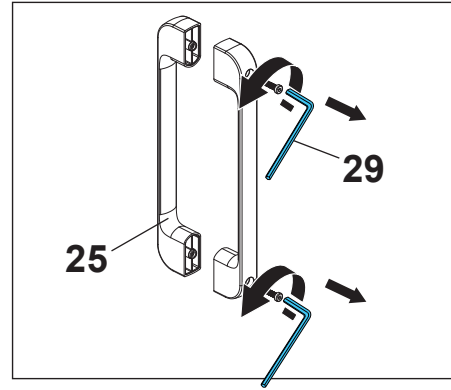

15A

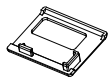
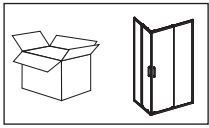

23. x1

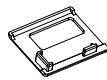

24. x1

A1

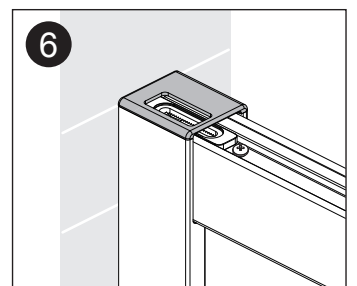
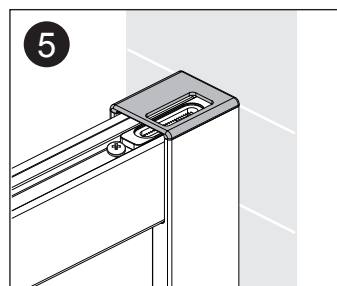
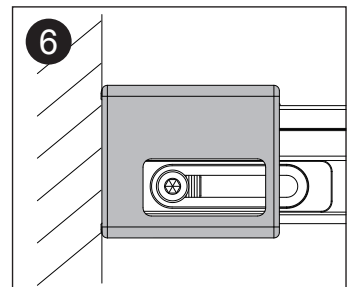
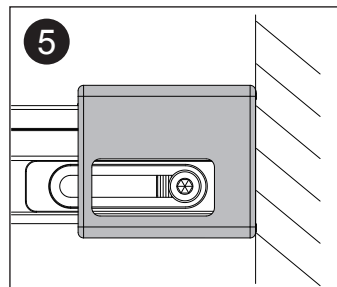
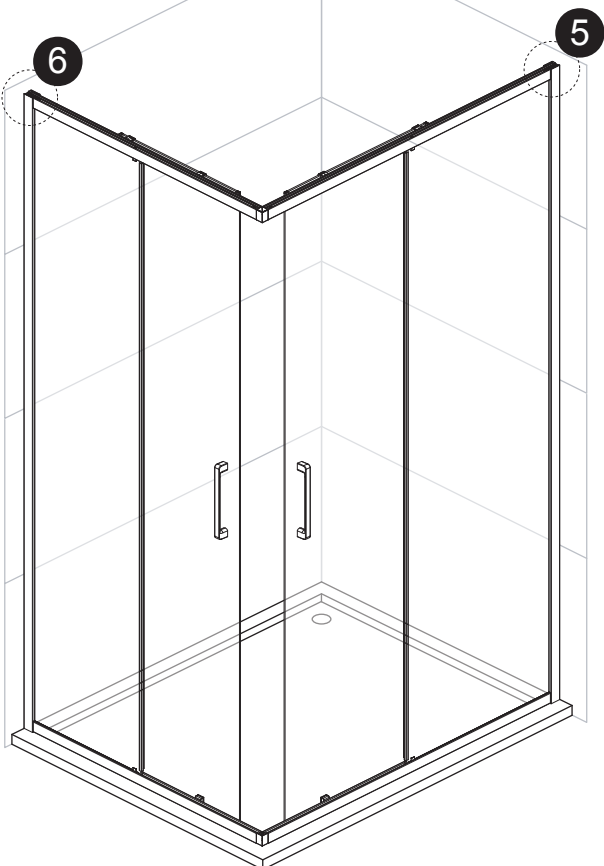
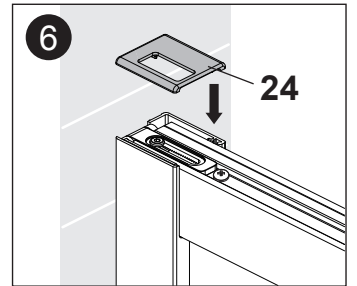
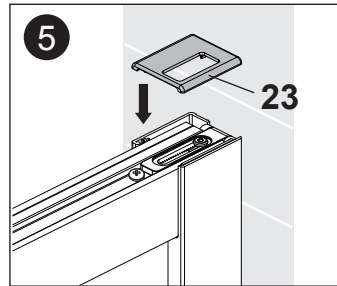
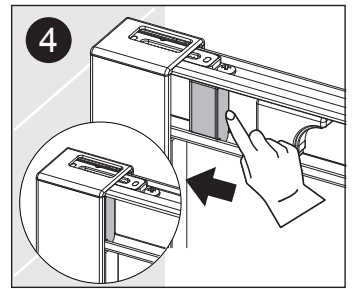
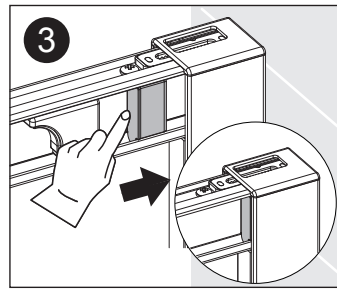
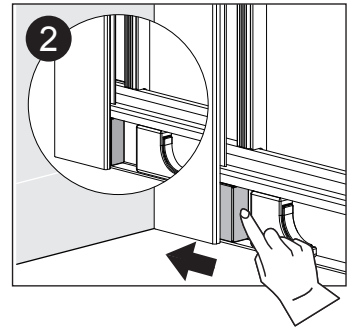
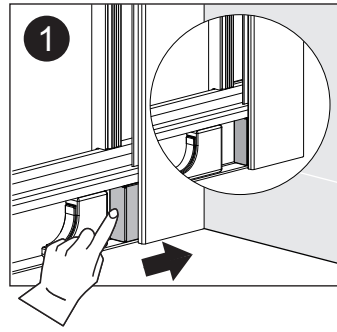
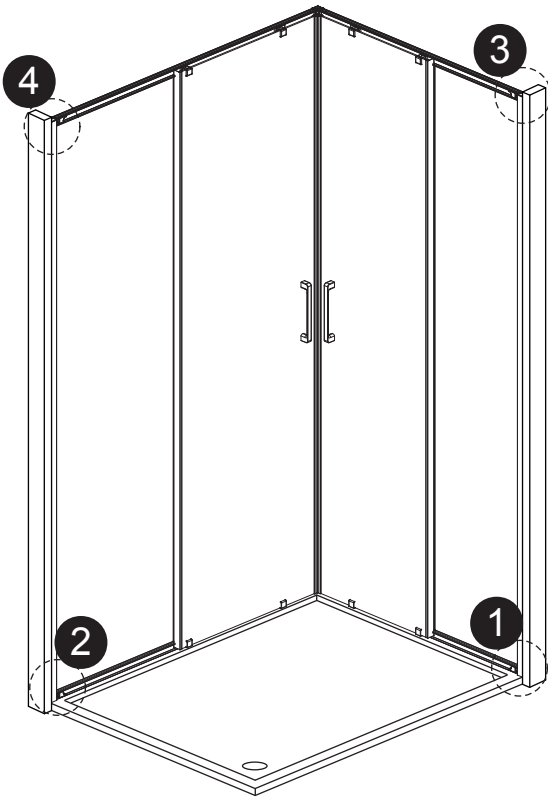

16A

A1

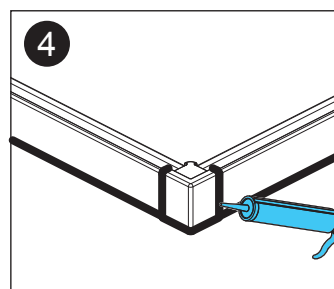
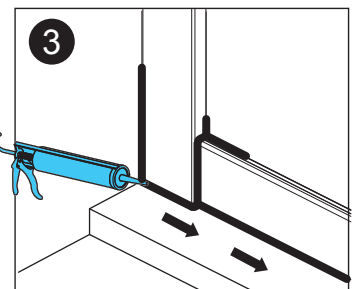
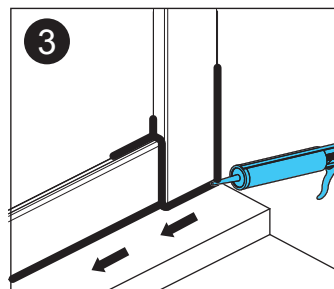
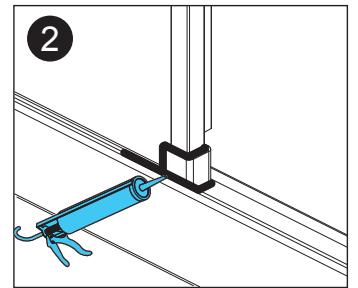
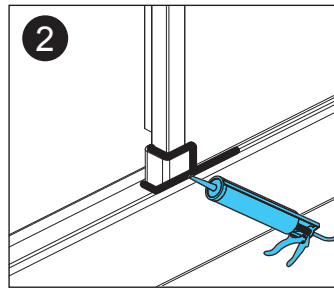
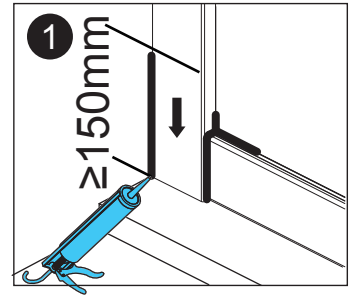
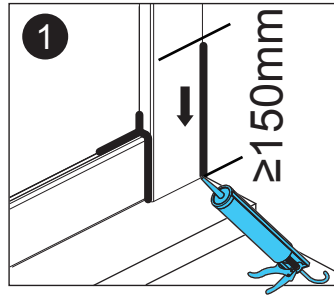
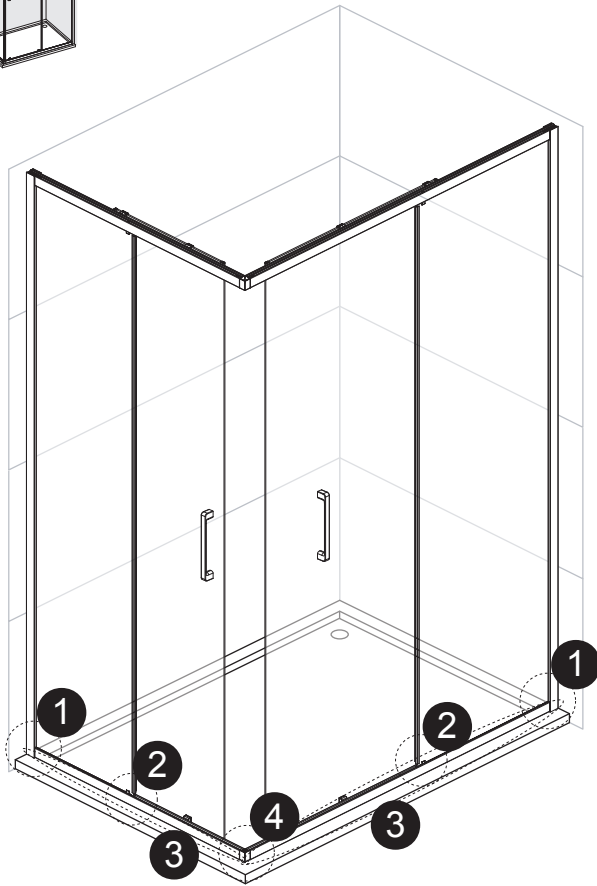

- EN** Do not use the shower enclosure for at least 24 hours in order to allow the silicone sealant to cure fully.
- FR** N'utilisez pas votre douche pendant au moins 24 heures afin de permettre aux joints de silicone de sécher entièrement.
- PL** Po zakończonym montażu, nie używaj brodzika prysznicowego przez co najmniej 24 godziny, aby umożliwić pełne osadzenie się uszczelnacza silikonowego.
- RO** Nu utilizați cab.ina de duș timp de cel puțin 24 pentru a permite izolației de silicon să se usuc complet.
- ES** No use la cabina de la ducha por lo menos 24 para dejar que el sellador de silicon se fragüe completamente.
- PT** Não utilize a divisória de chuveiro durante, no mínimo, 24 horas para garantir que o vedante silicone fica totalmente seco.

1B

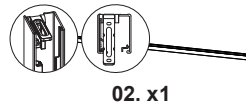
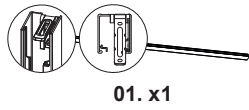
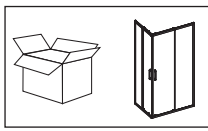

B1



| SIZE (mm) | A(mm) |
|-----------|-------|
| 700×900 | 682 |
| 700×1000 | 982 |
| 700×1200 | 1182 |

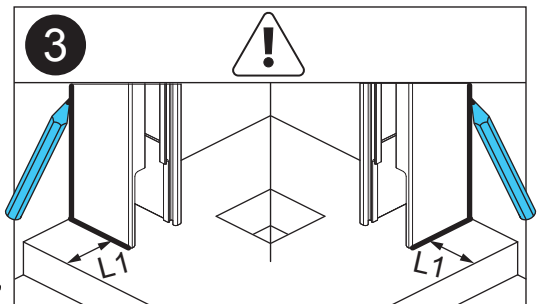
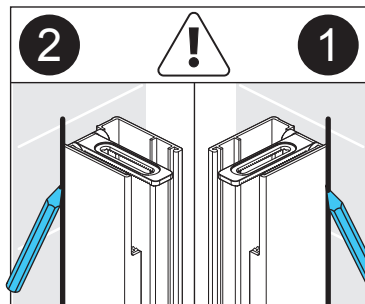
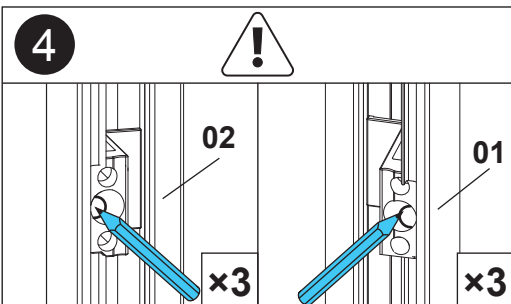
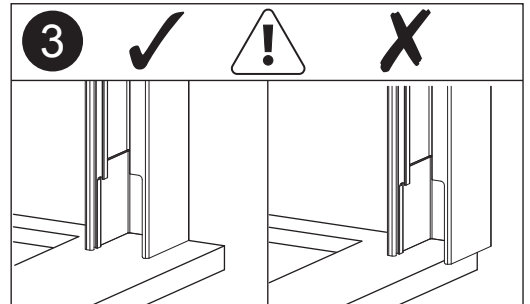
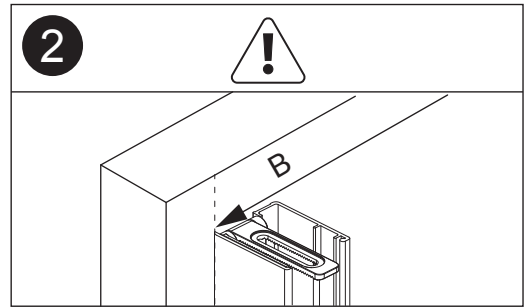
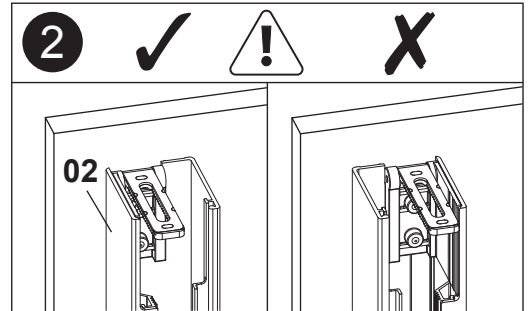
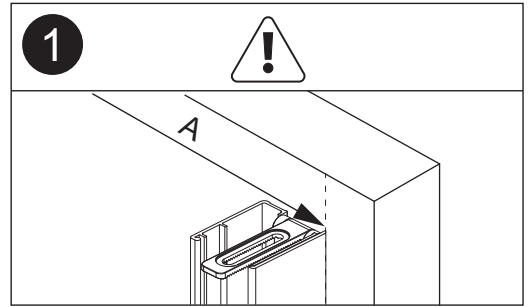
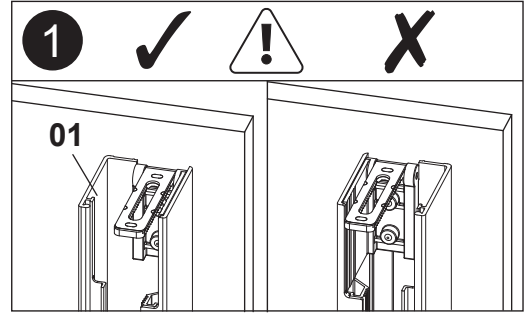
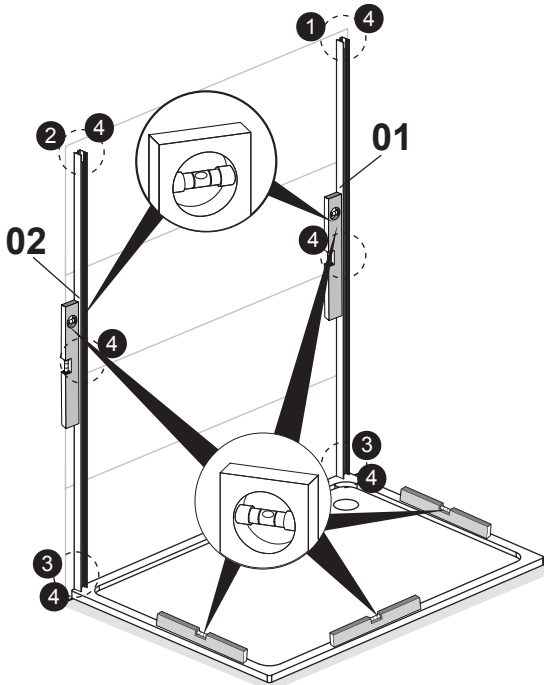
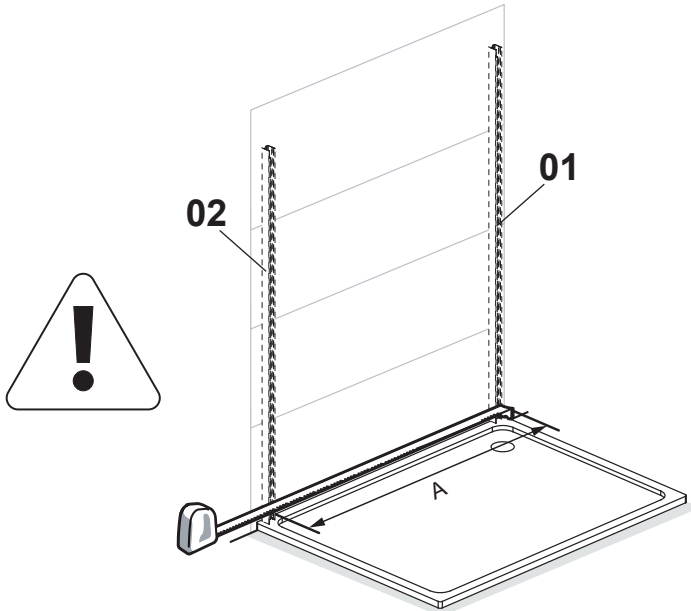

2B

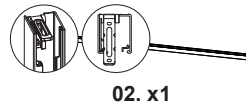
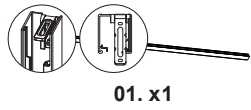
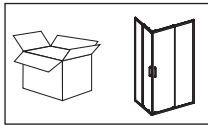

B1

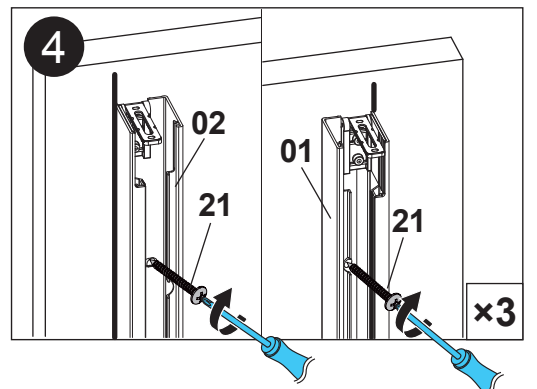
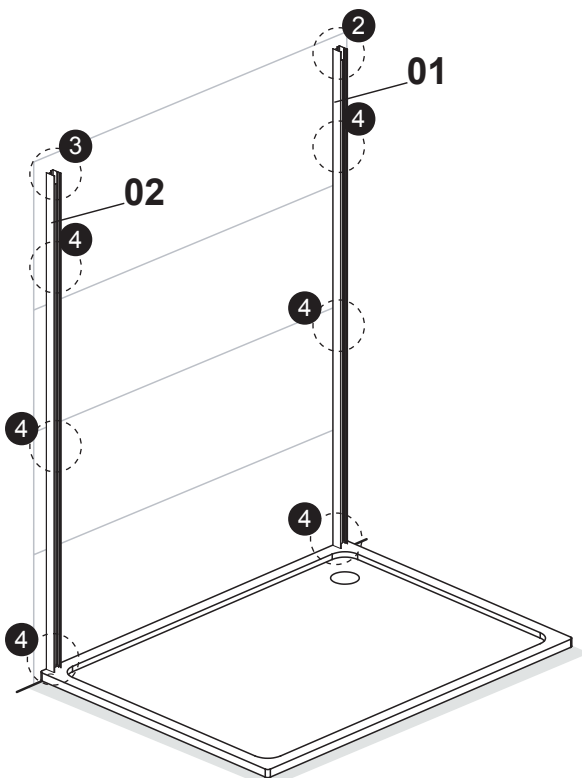
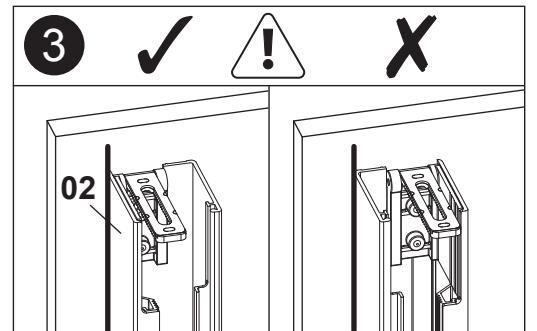
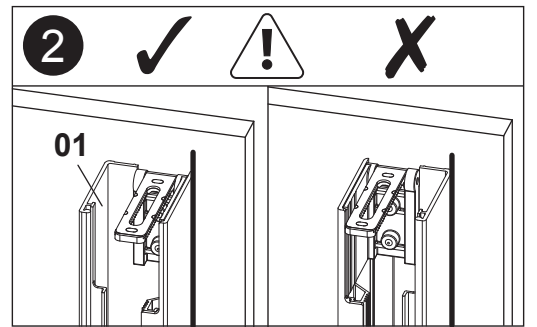
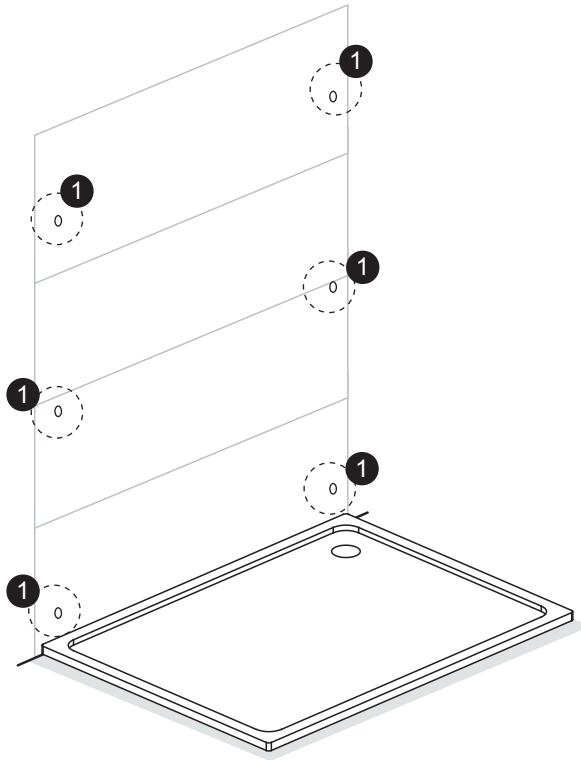
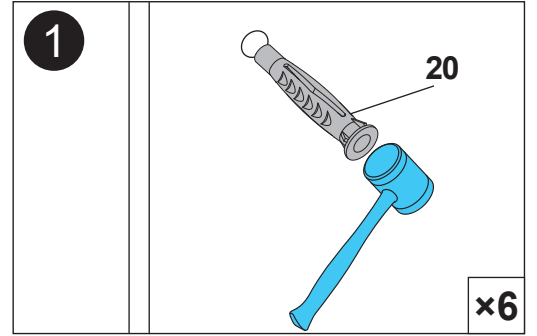
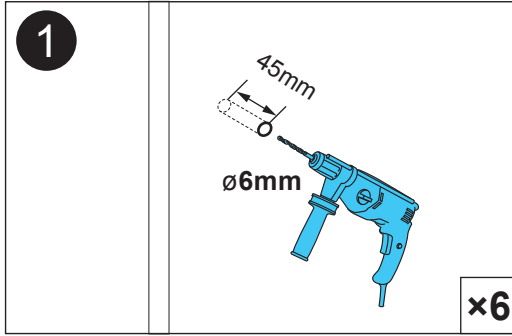

3B

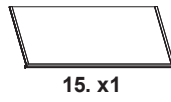
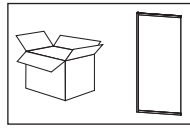
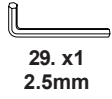
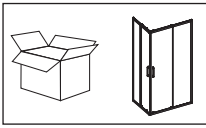

B1

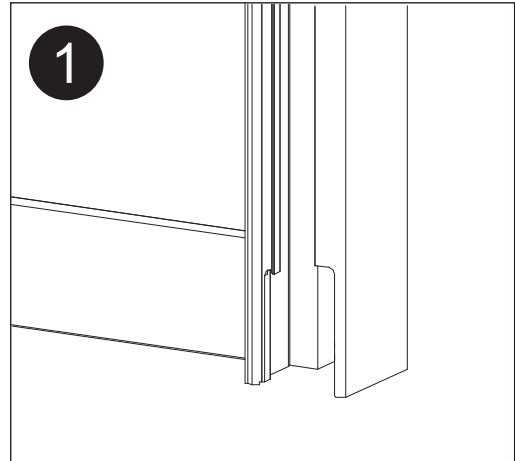
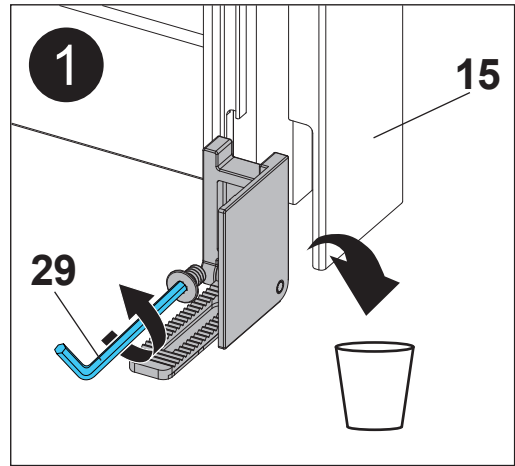
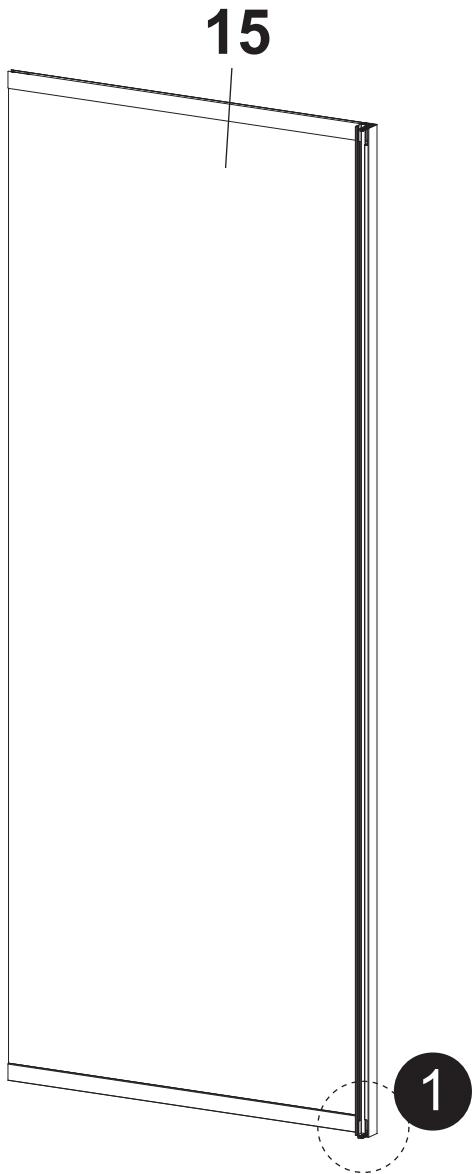

4B

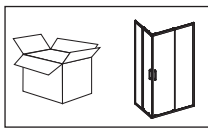

22. x2
M4x10mm

29. x1
2.5mm

30. x1

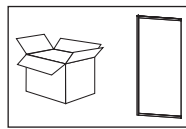

15. x1

08. x1

B1

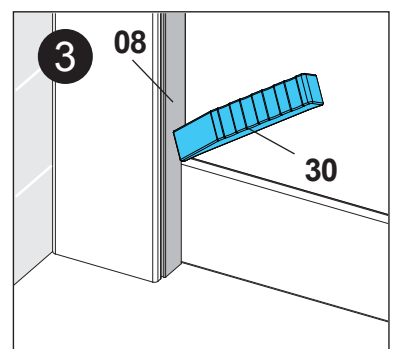
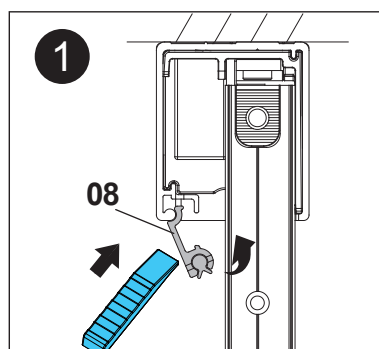
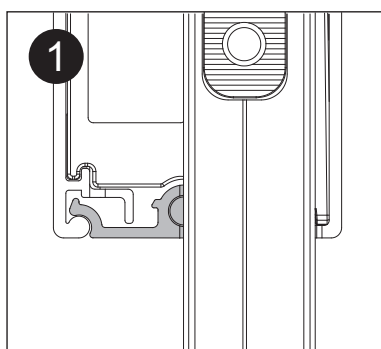
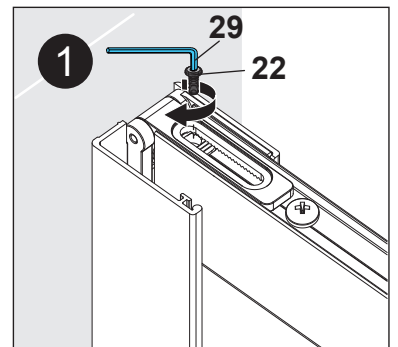
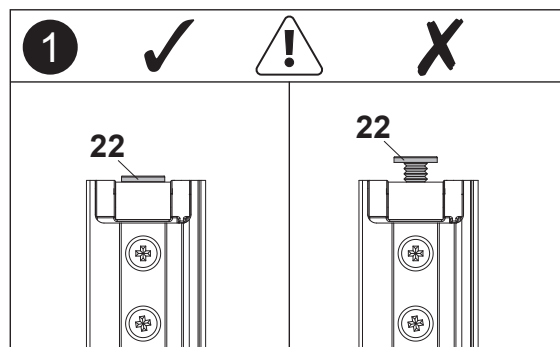
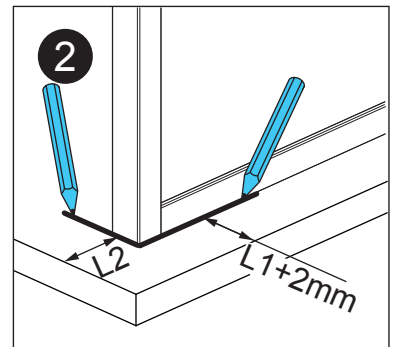
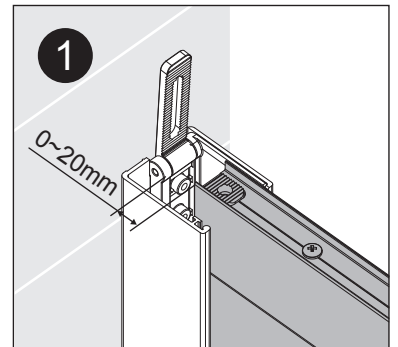
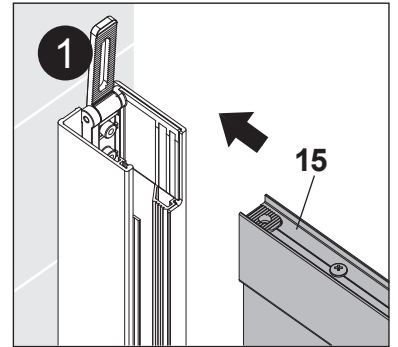
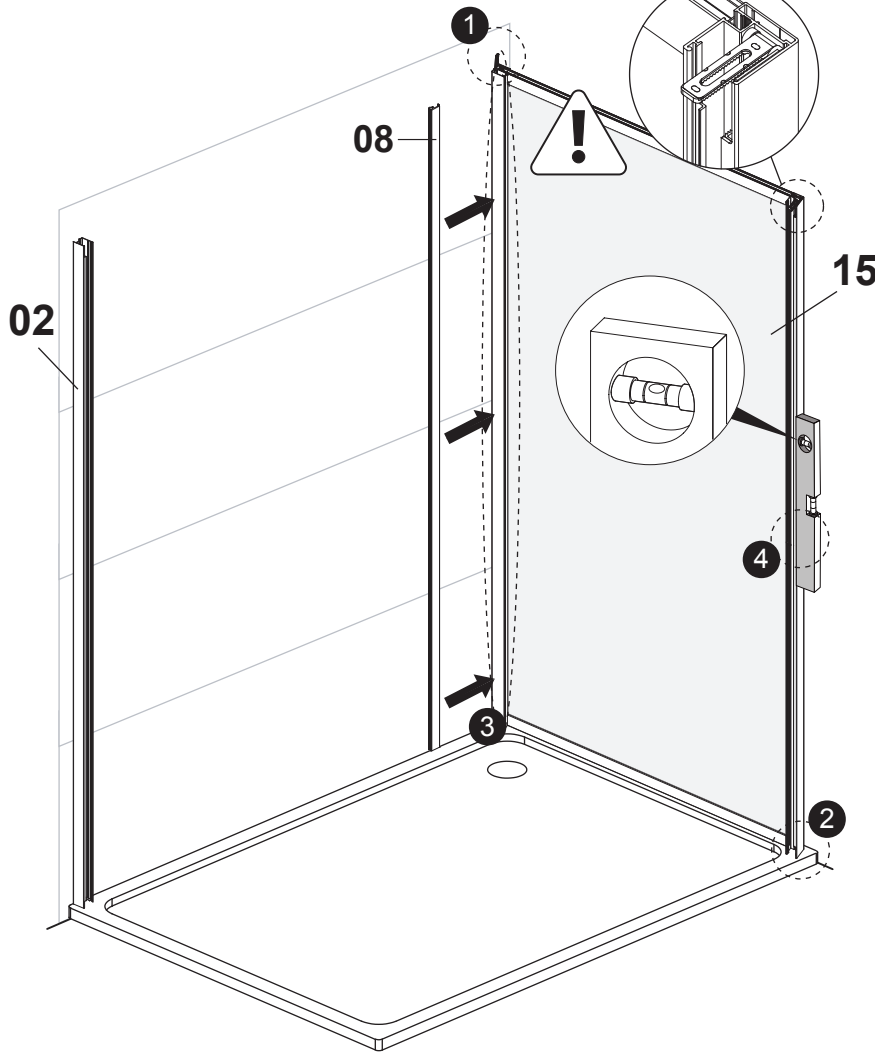

5B

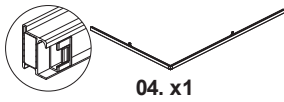
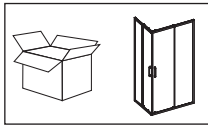

04. x1

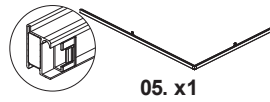

05. x1

B1

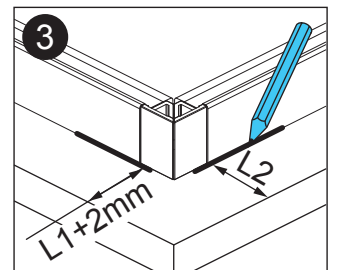
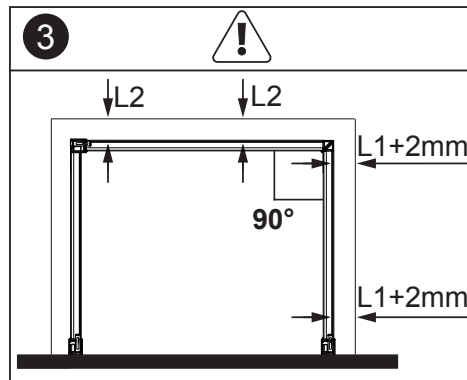
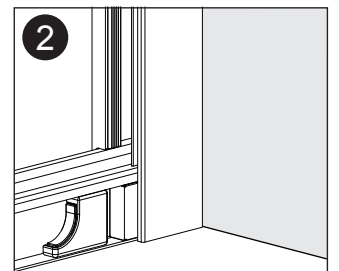
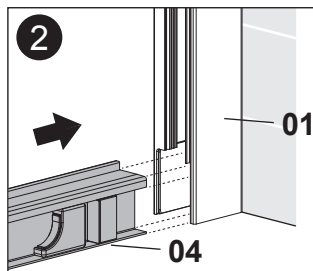
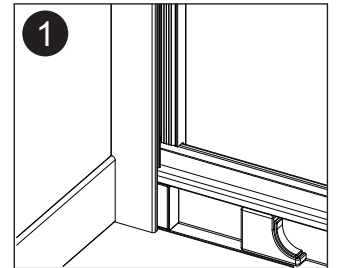
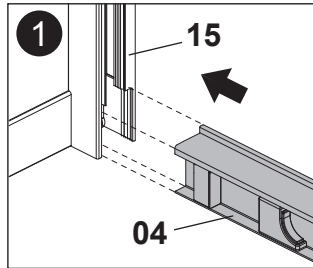
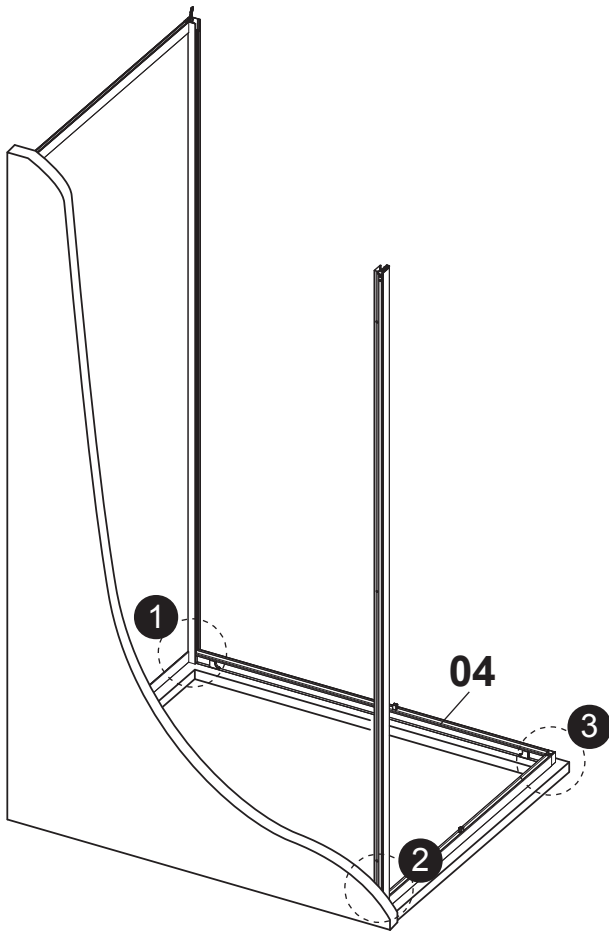
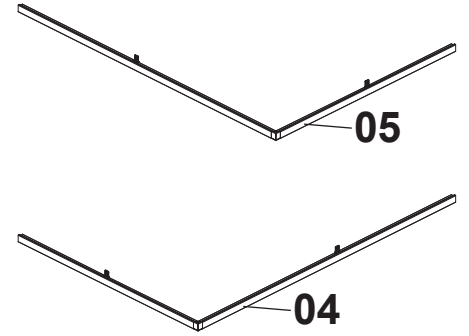
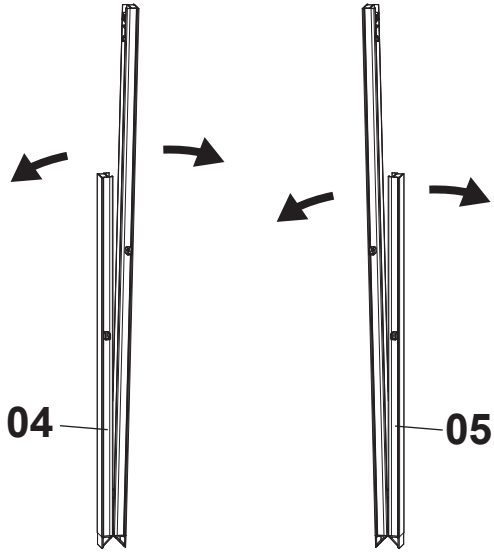

6B

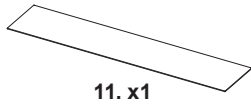
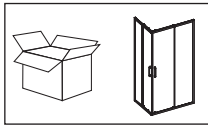

11. x1

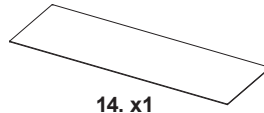

14. x1



50-1. x2



50-2. x2

B1

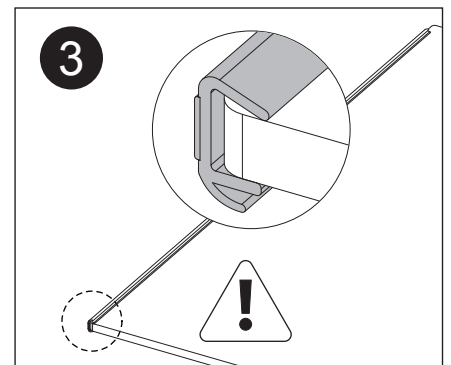
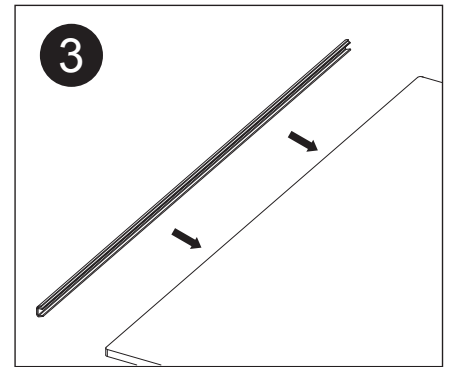
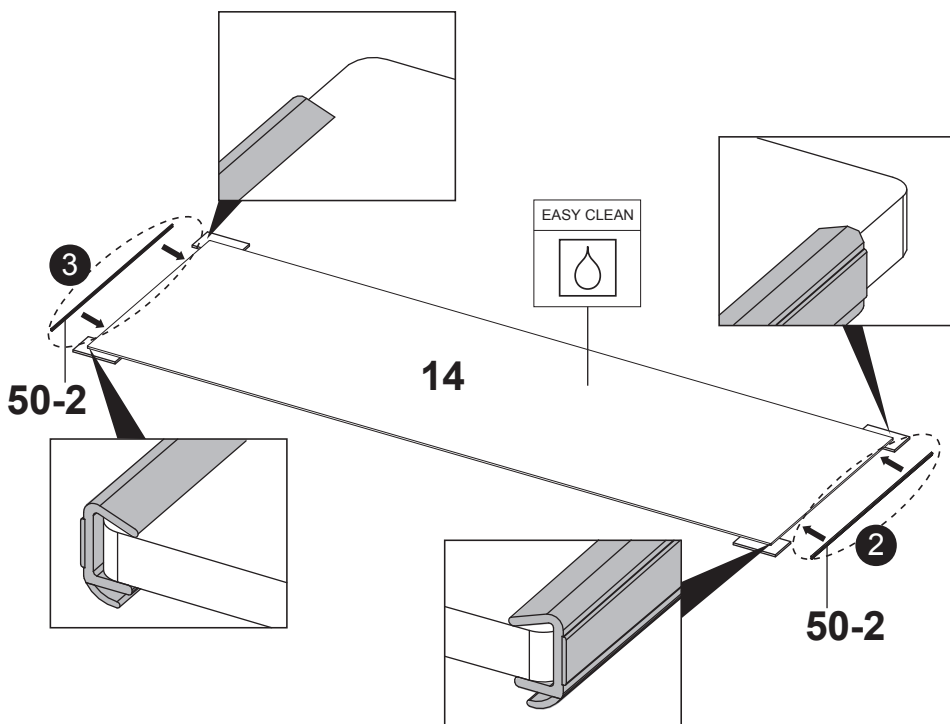
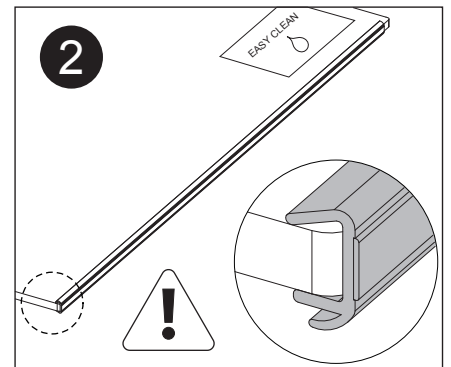
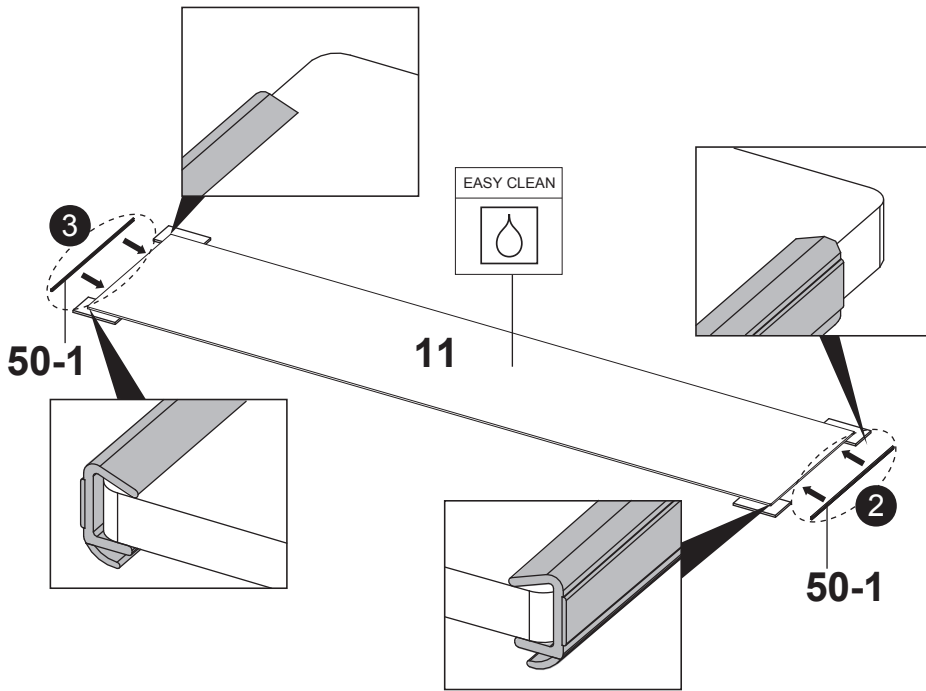
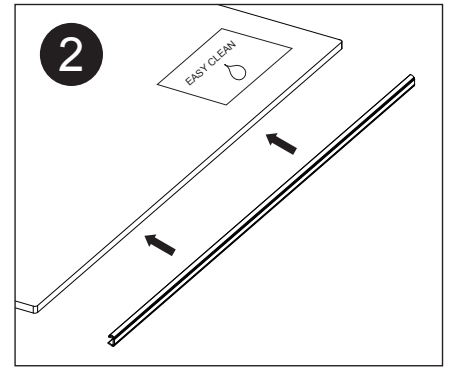
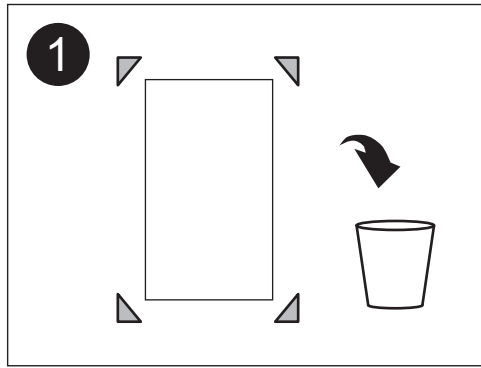

7B

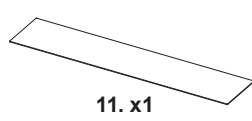
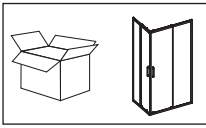

11. x1

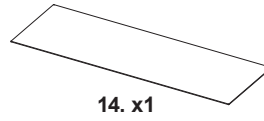

14. x1

B1

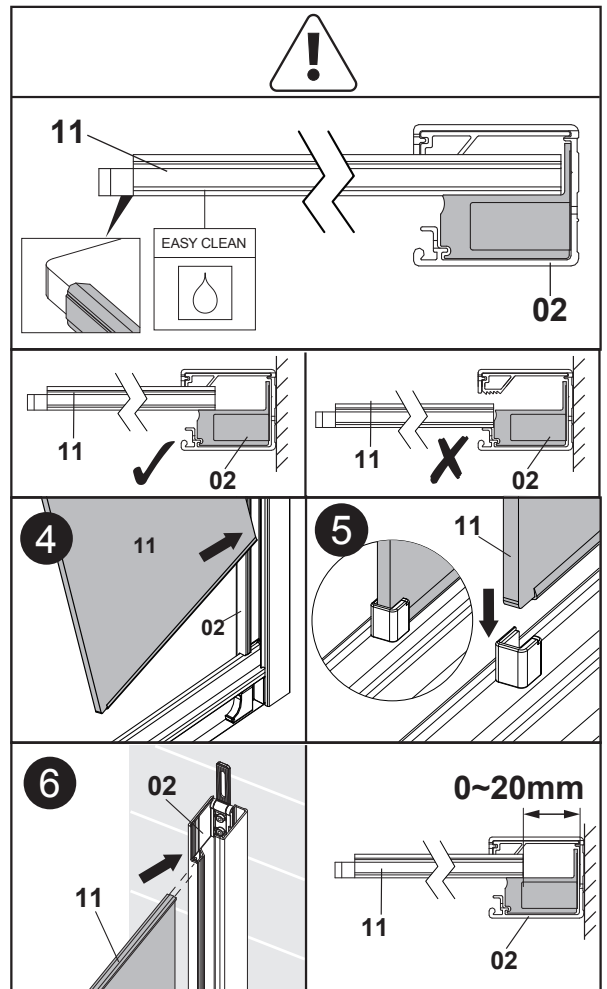
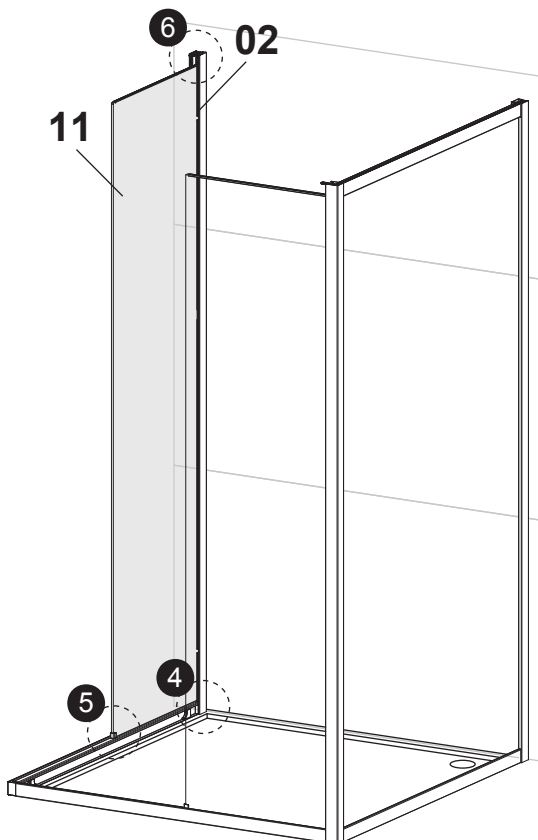
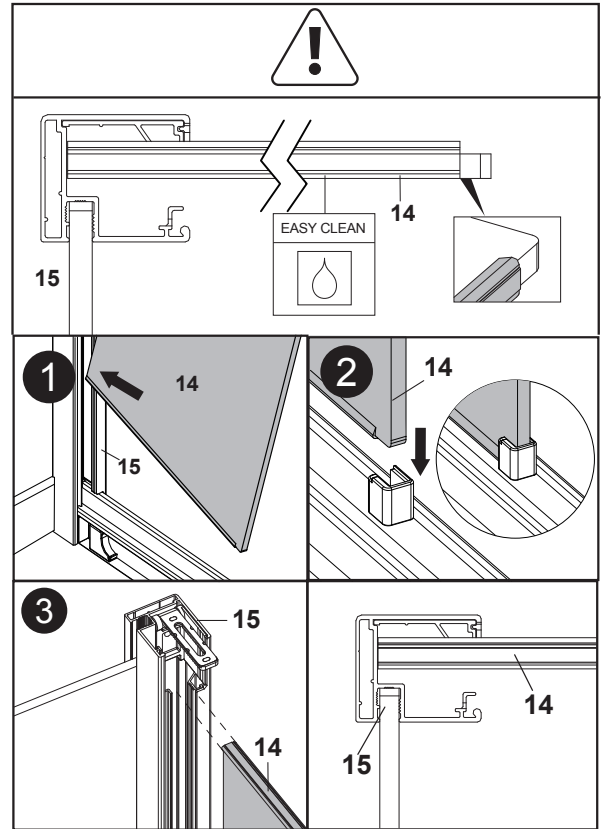
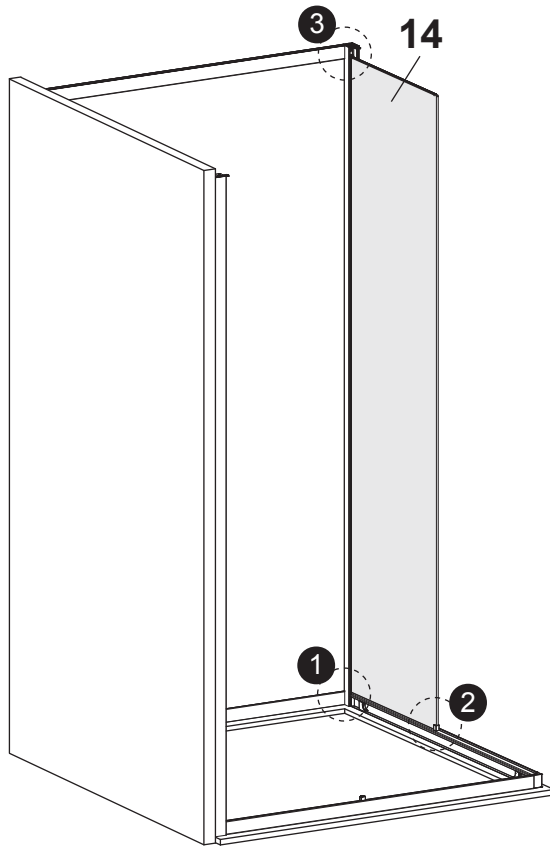

8B

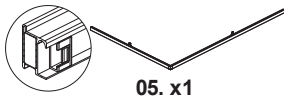
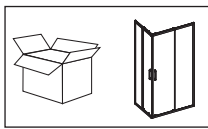

05. x1



22. x2
M4x10mm

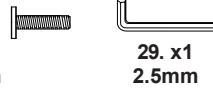

29. x1
2.5mm

B1

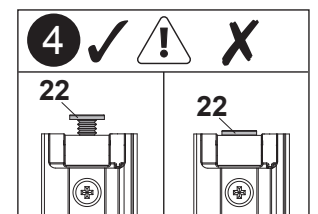
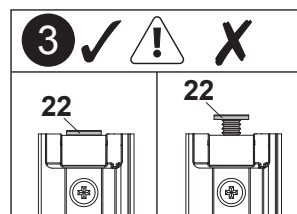
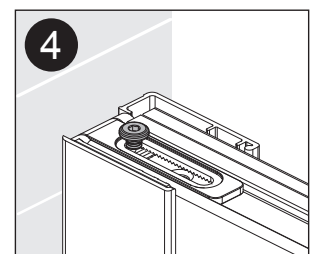
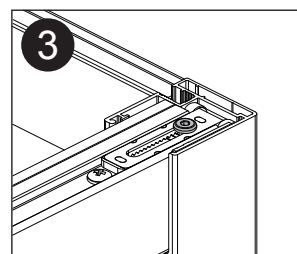
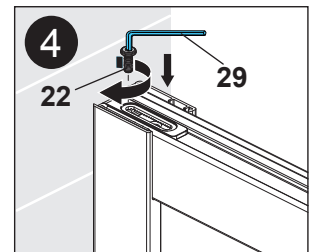
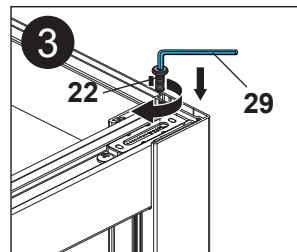
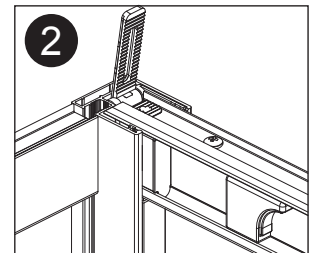
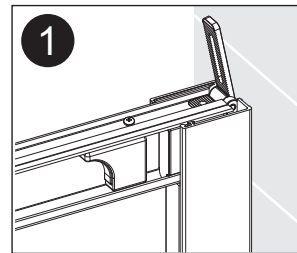
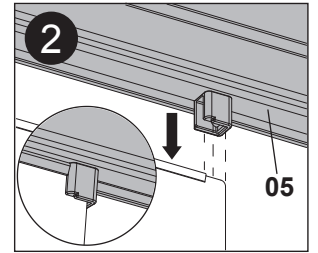
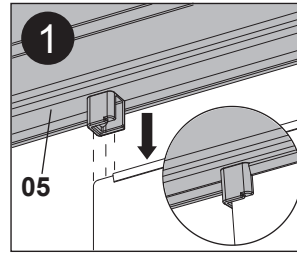
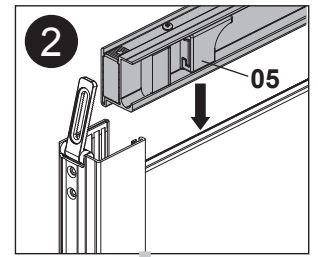
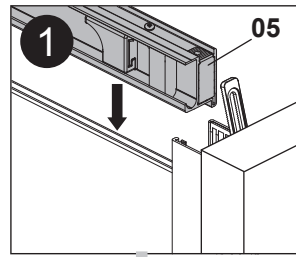
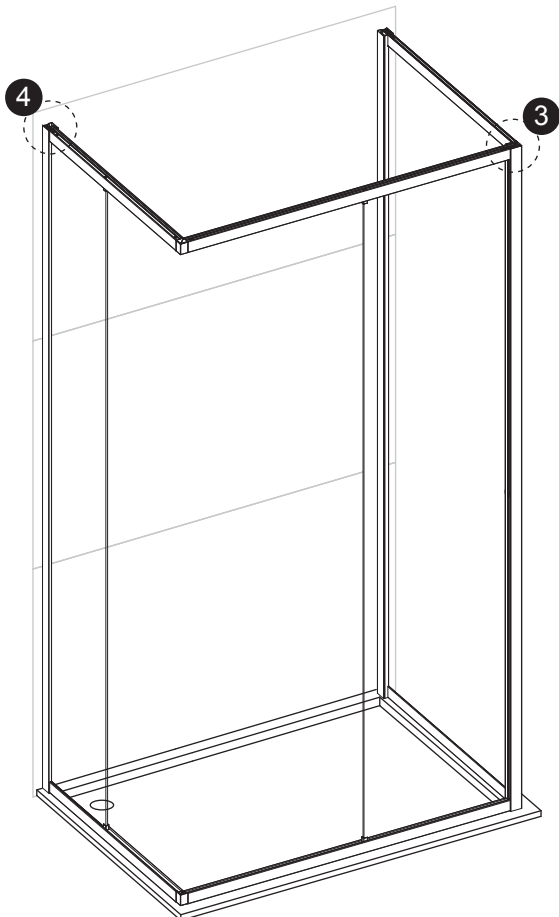
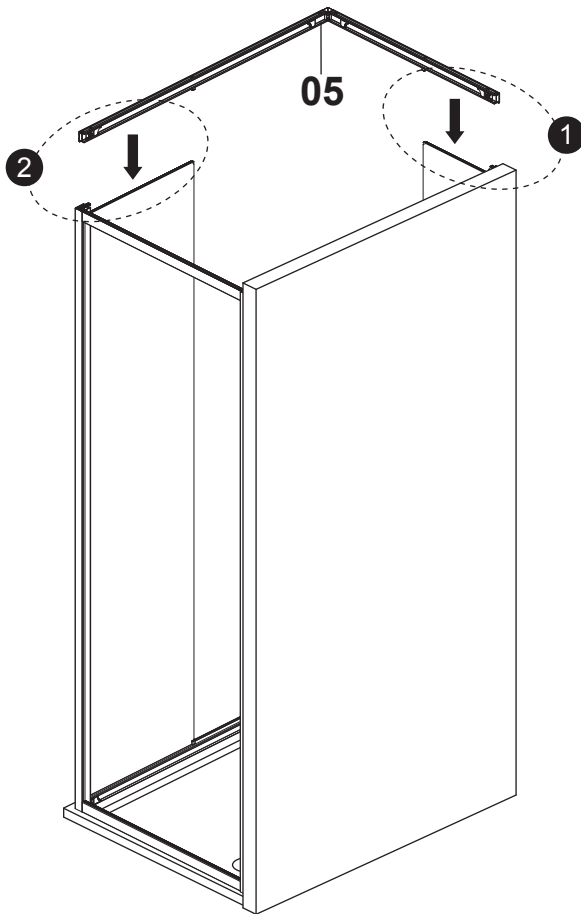

9B

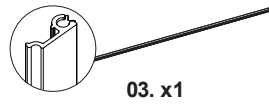
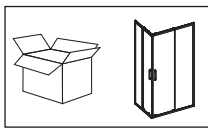

03. x1

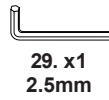

29. x1
2.5mm

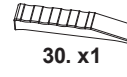

30. x1

B1

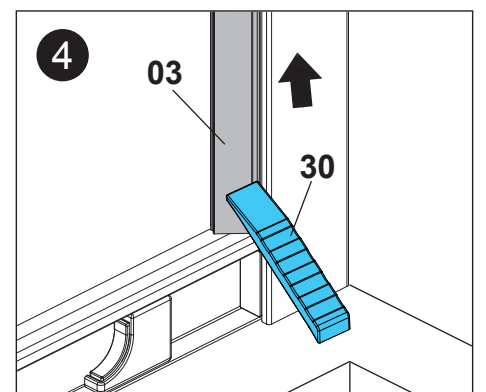
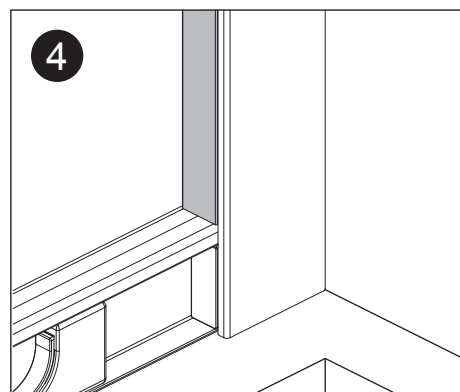
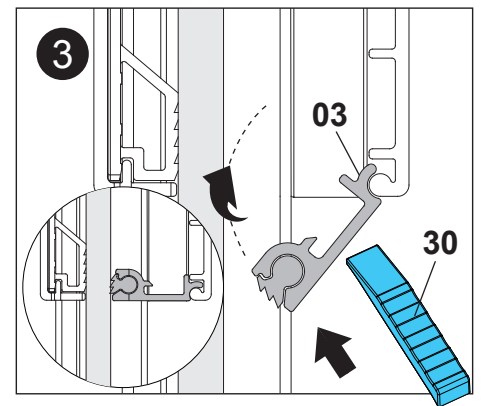
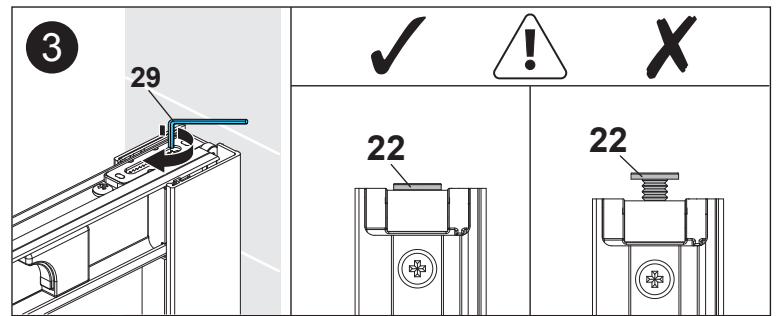
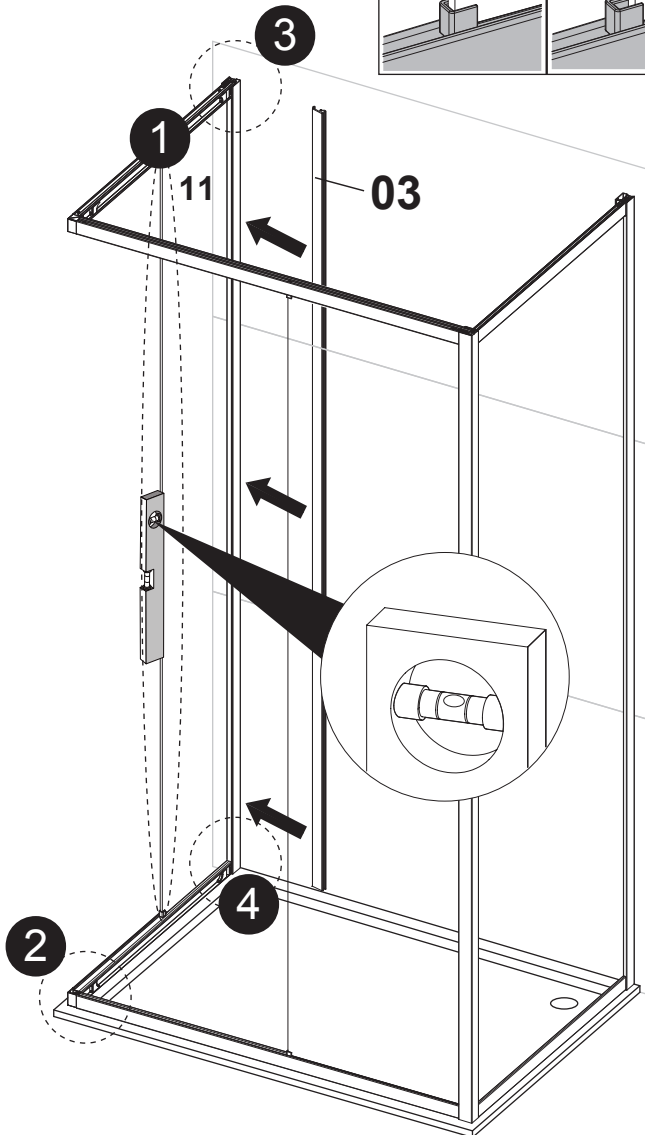
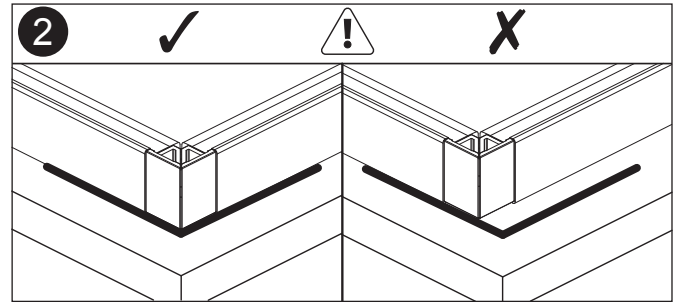
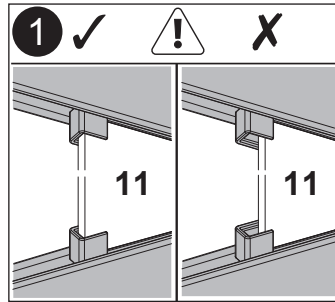

10B

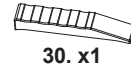
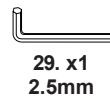
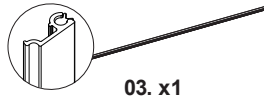
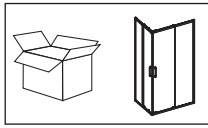

B1

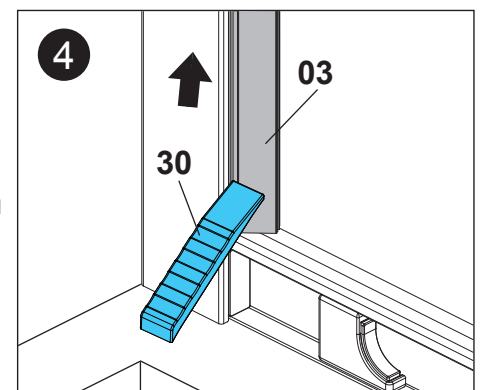
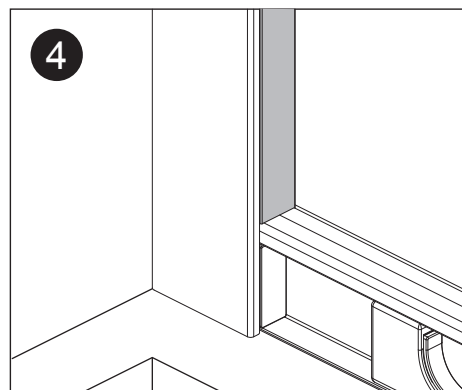
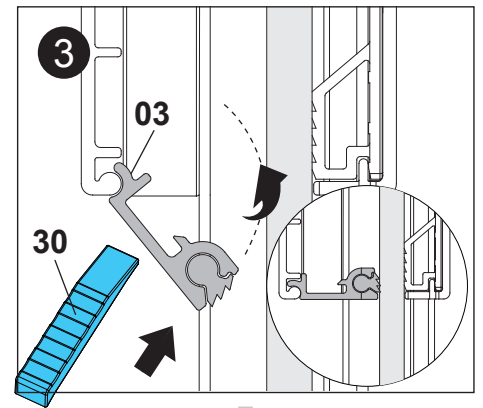
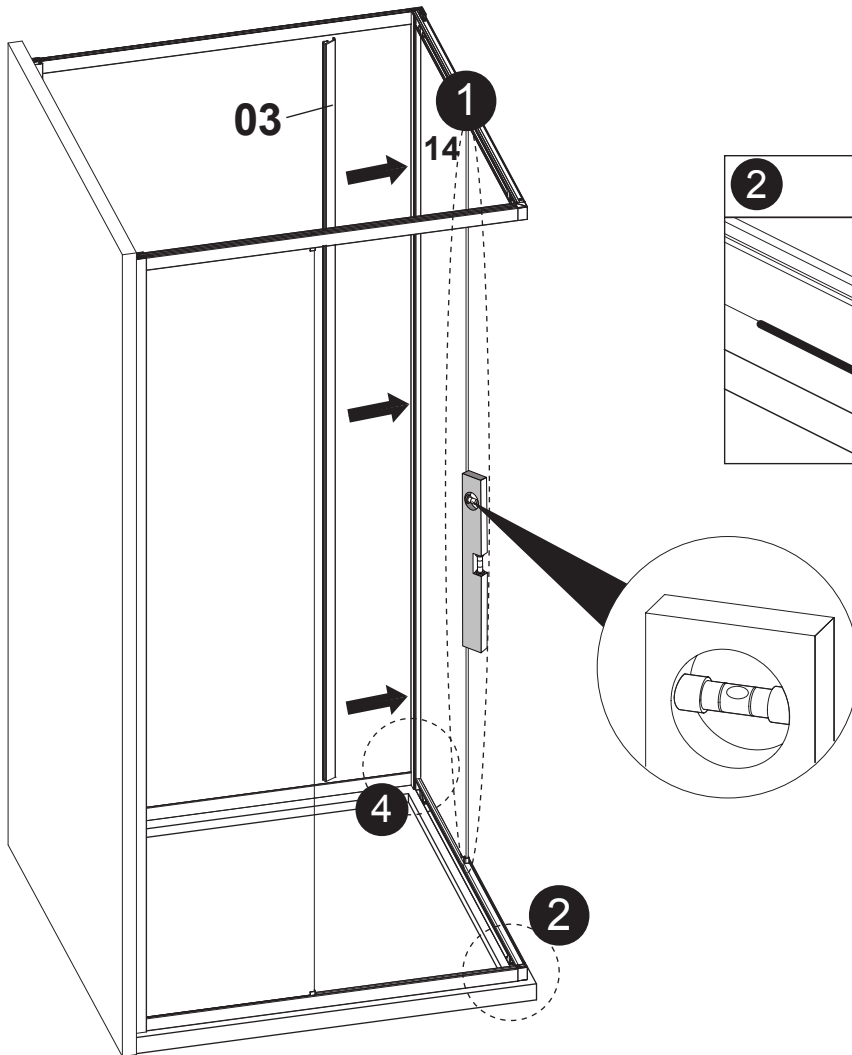
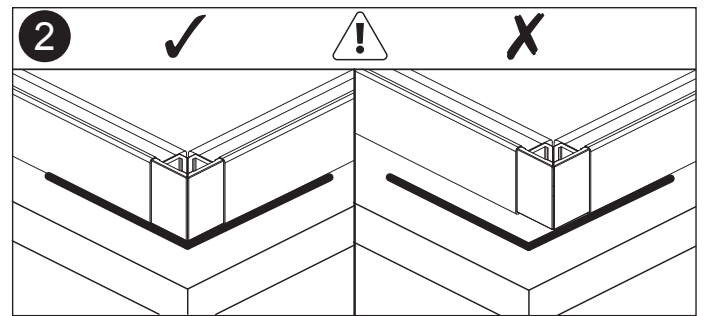
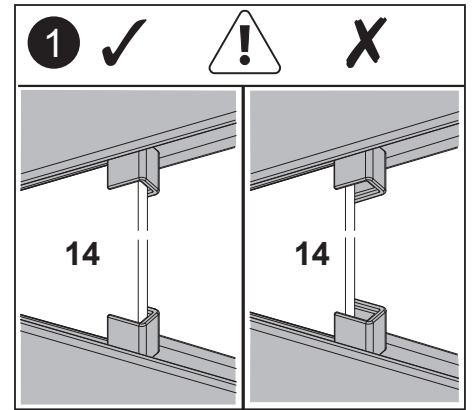

11B

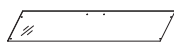
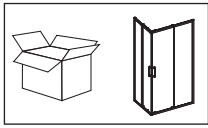

12. x1

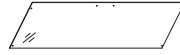

13. x1



26. x4



27. x4



29. x1
2.5mm

B1

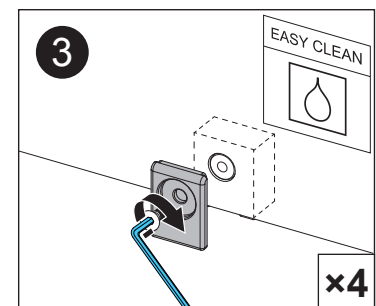
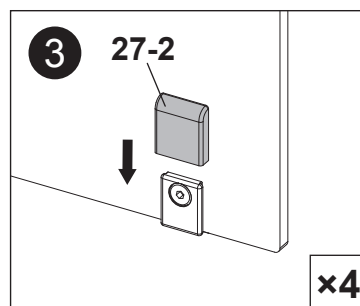
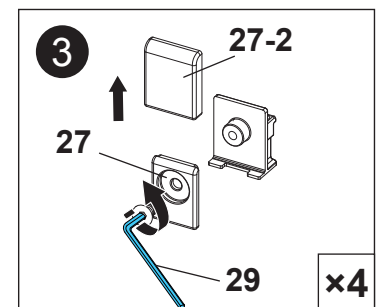
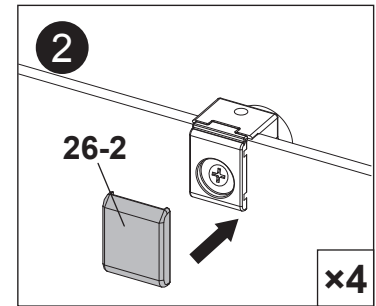
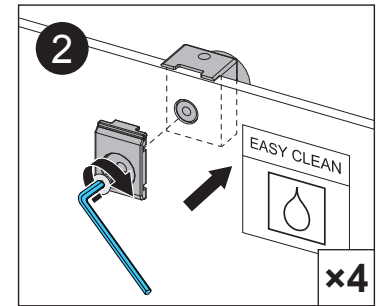
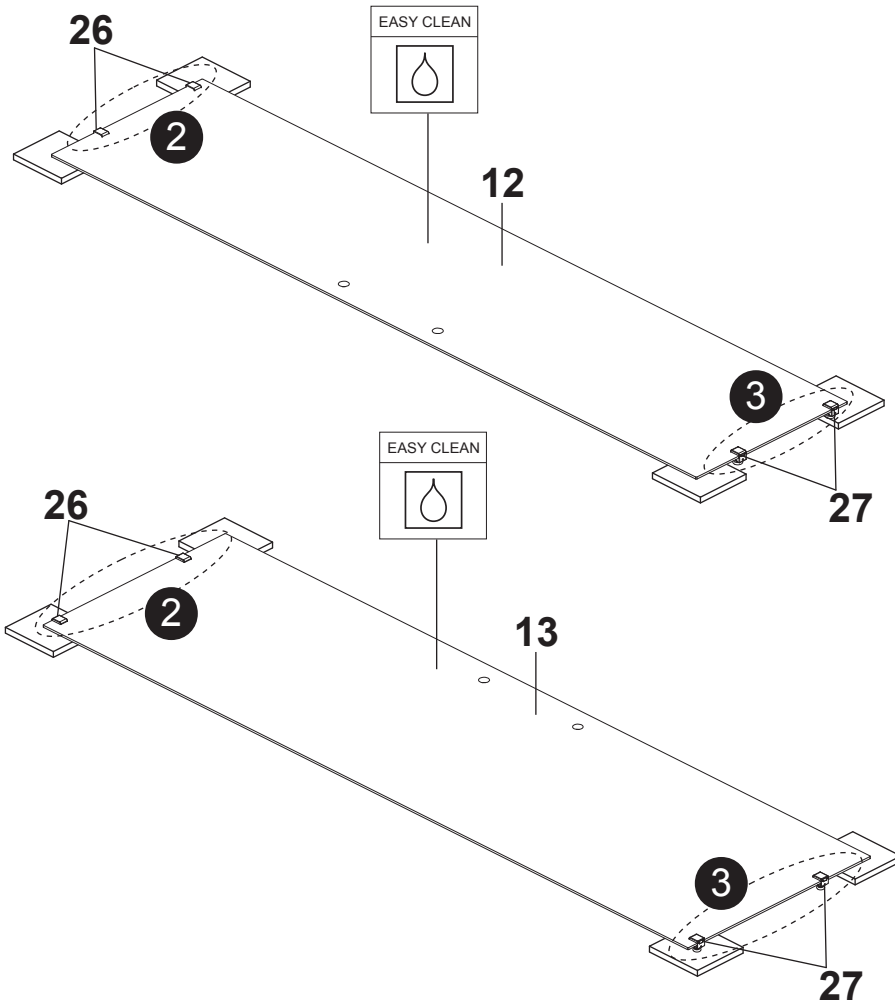
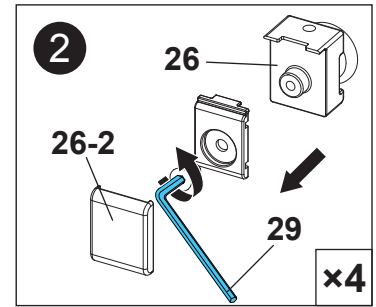
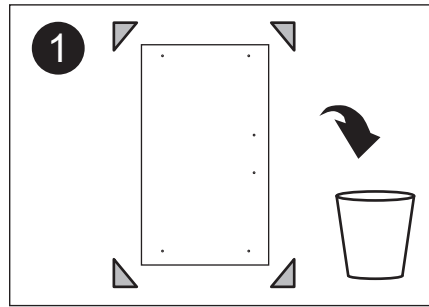

12B

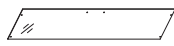
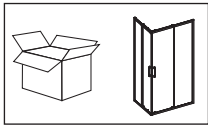

12. x1



13. x1

B1

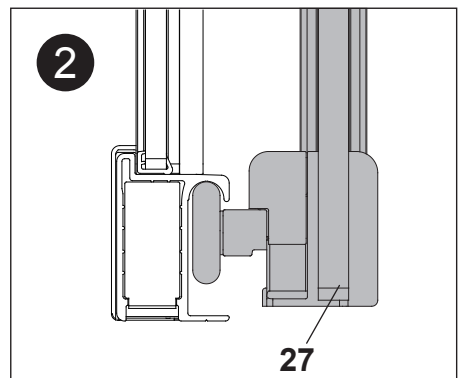
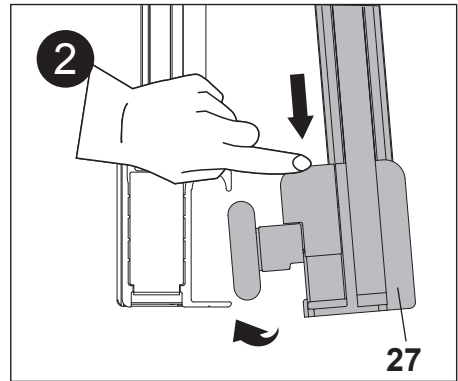
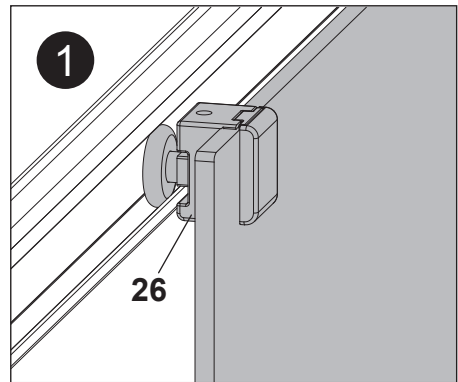
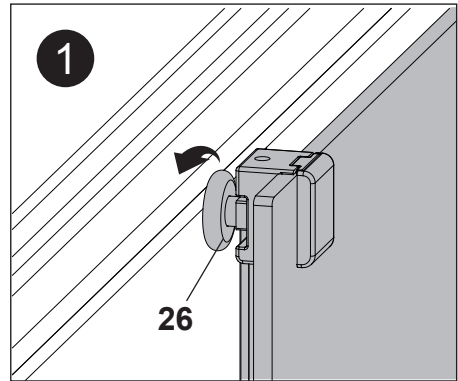
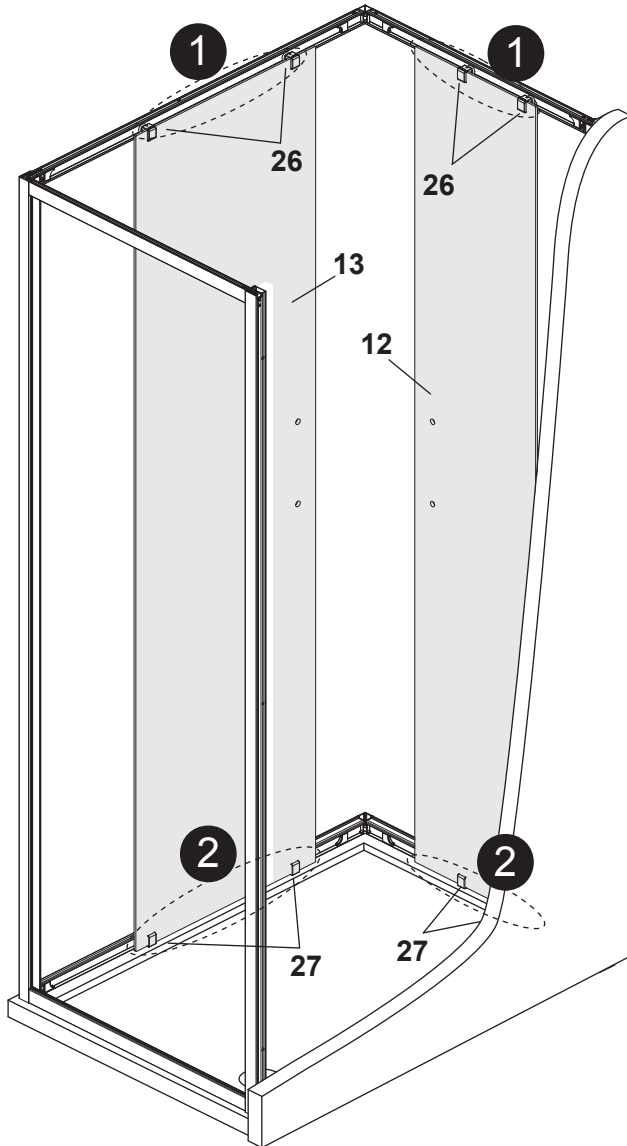

13B

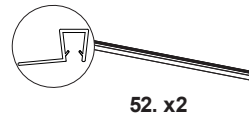
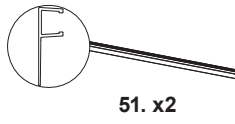
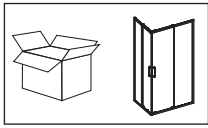

51. x2

52. x2

B1

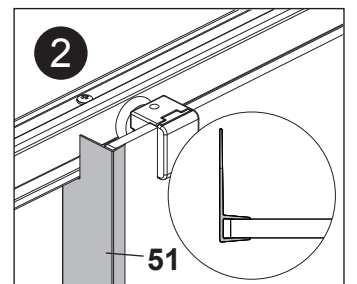
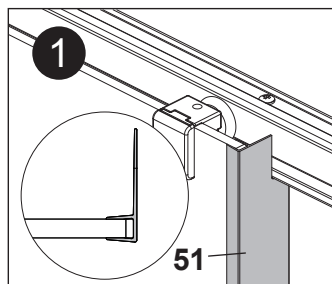
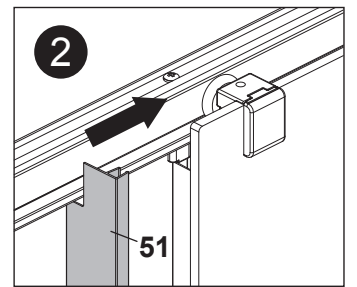
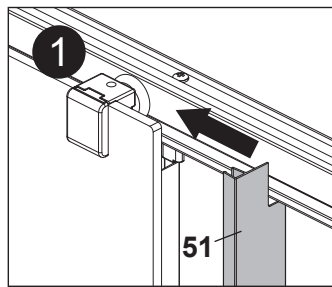
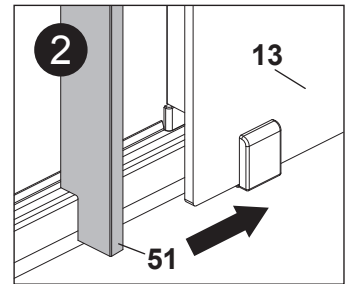
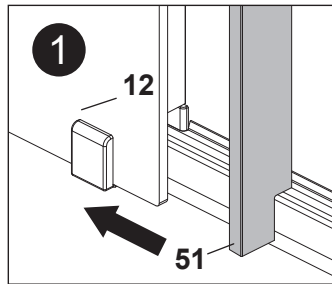
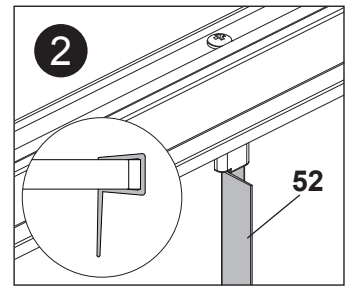
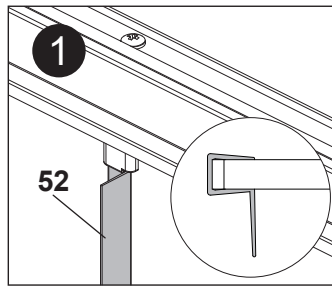
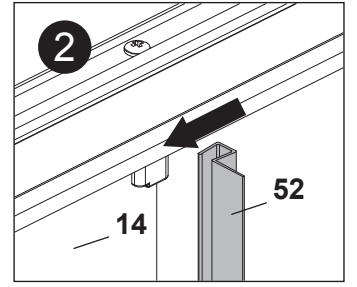
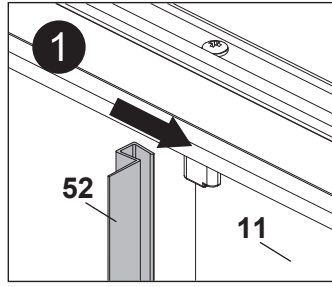
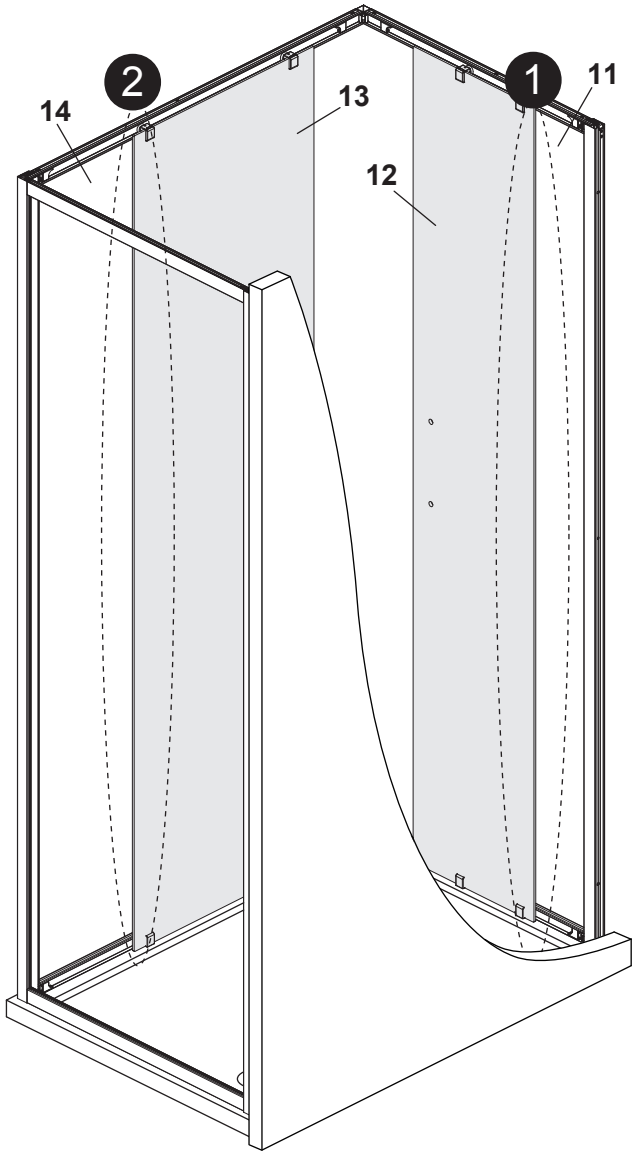

14B

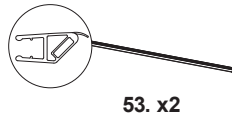
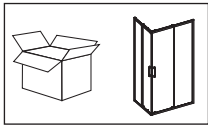

B1

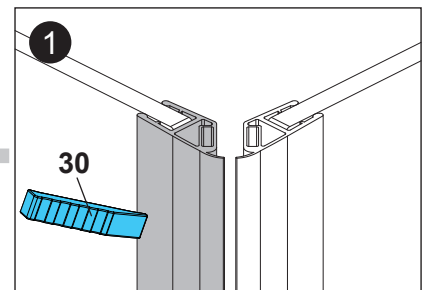
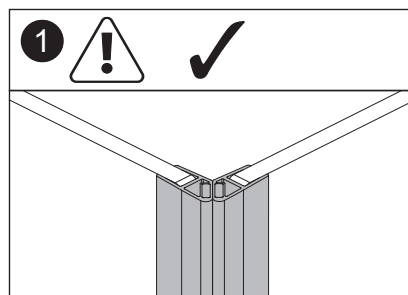
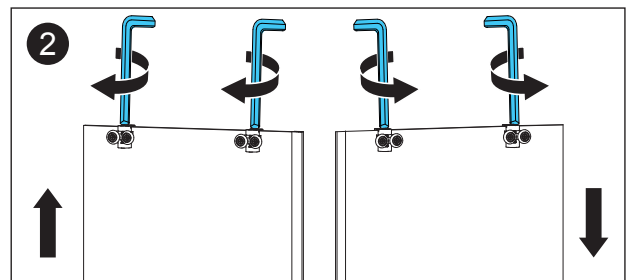
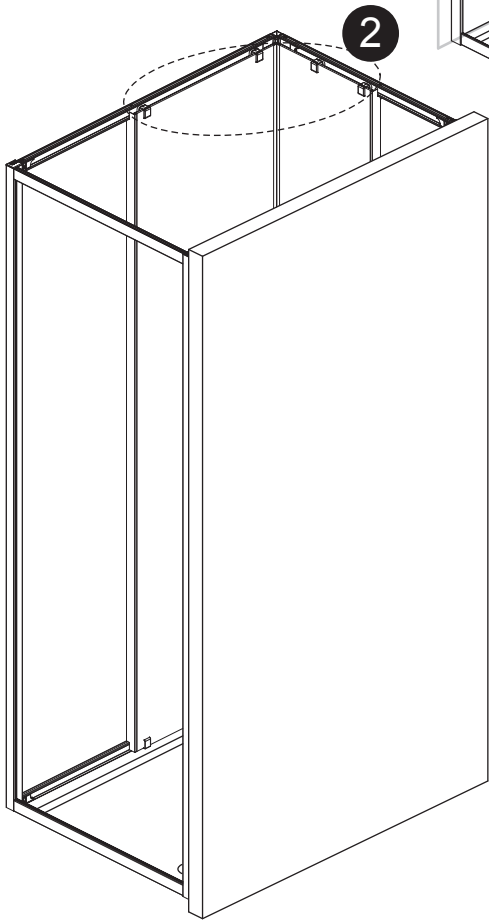
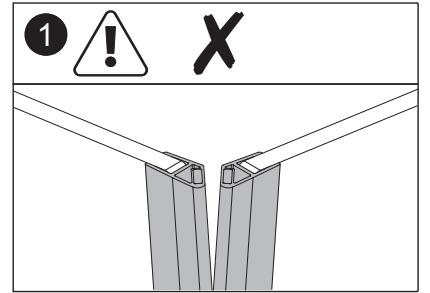
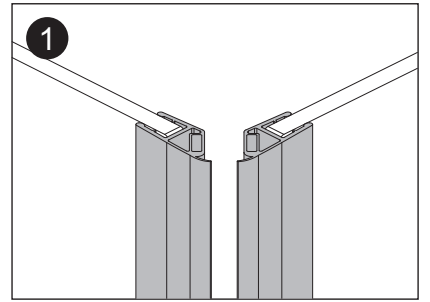
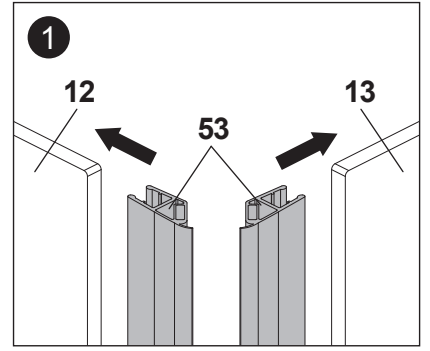
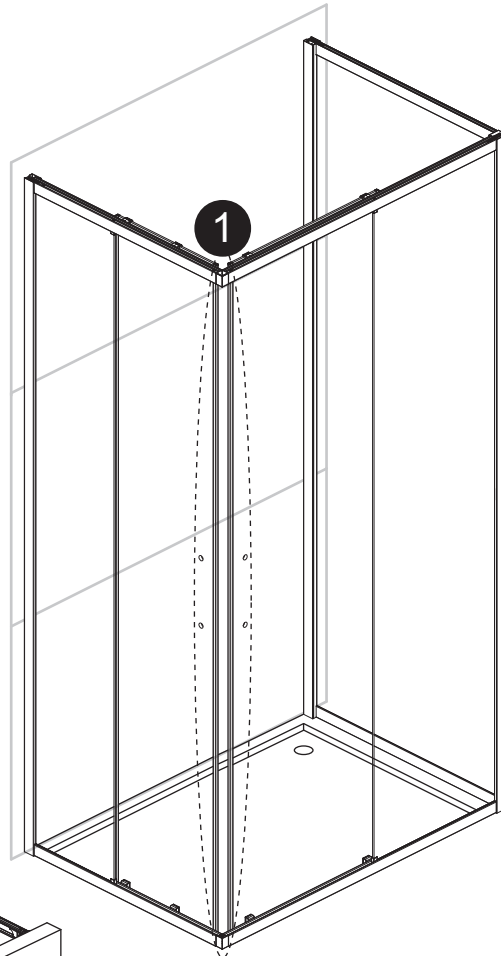

15B

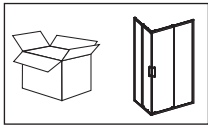

28. x2

B1

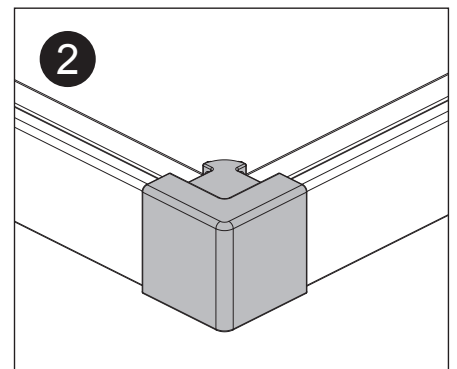
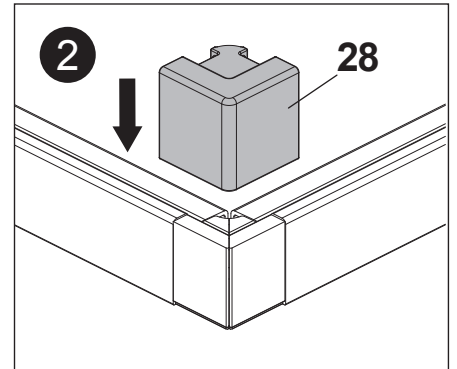
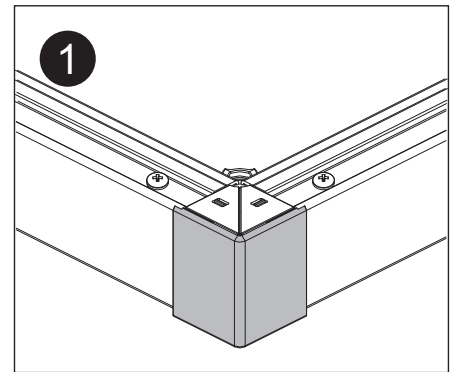
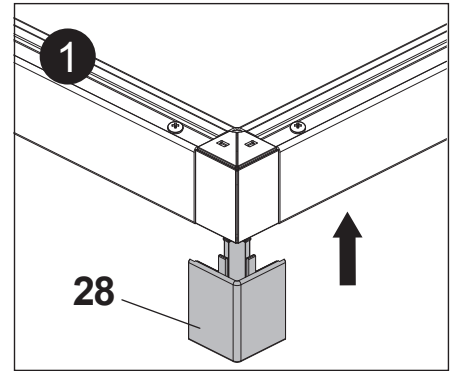
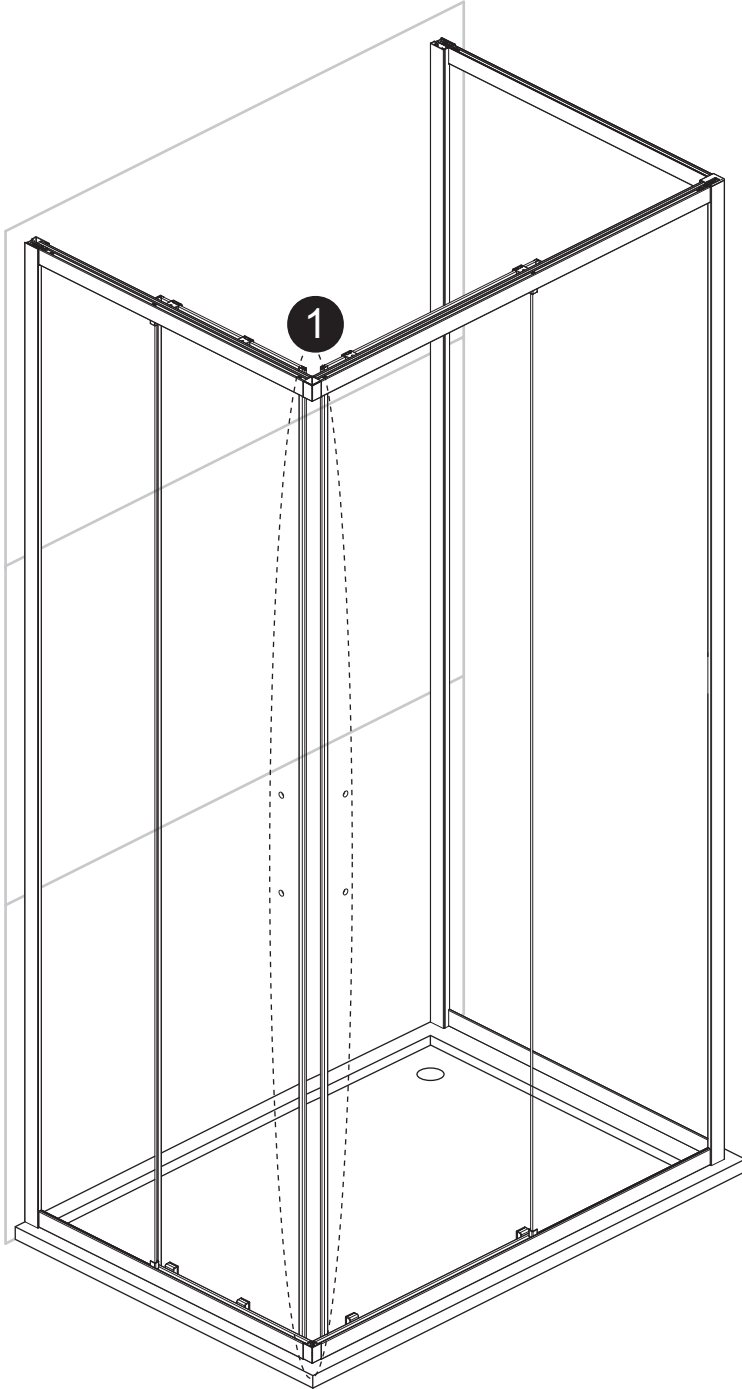

16B

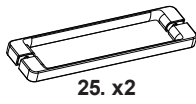
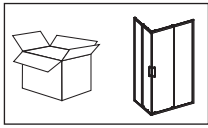

B1

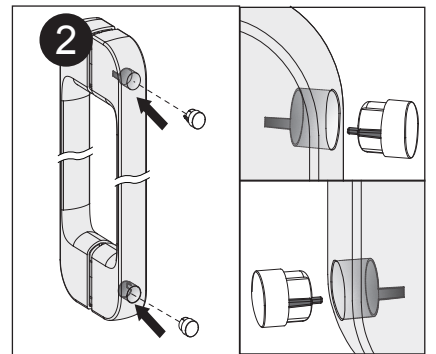
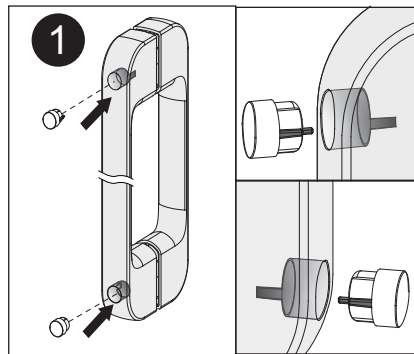
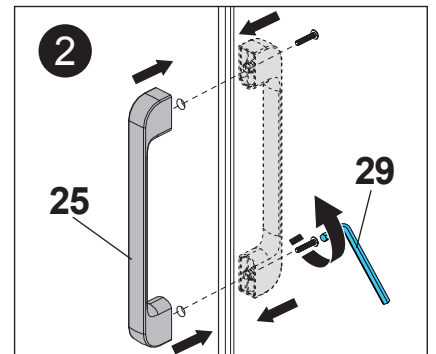
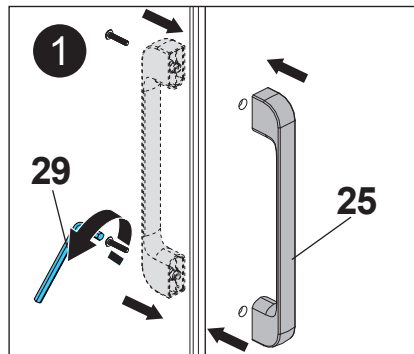
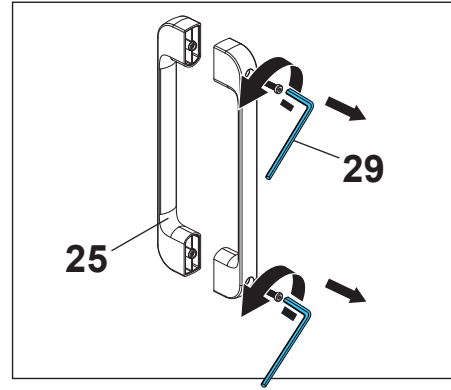
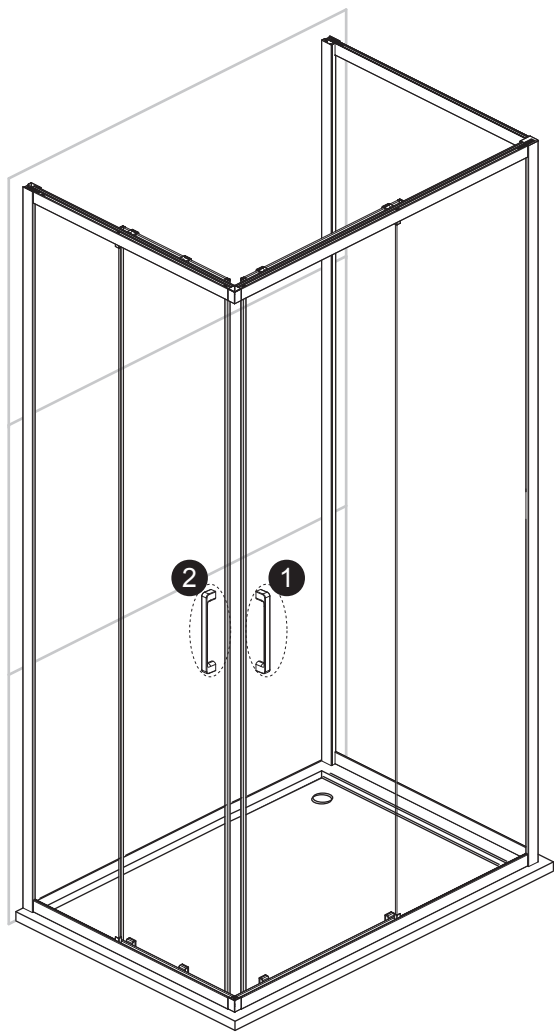

17B

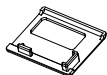
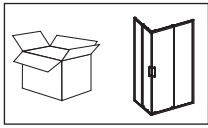

23. x1

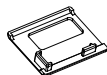

24. x1

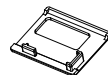
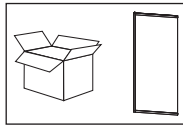

23. x1

B1

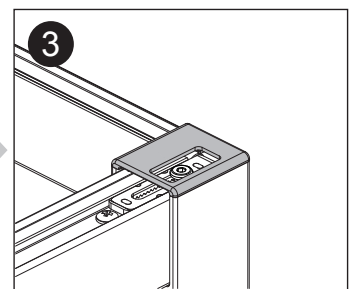
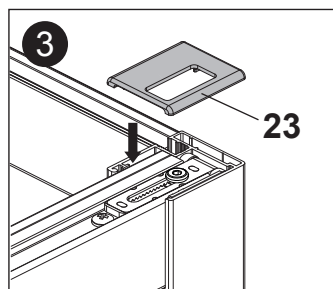
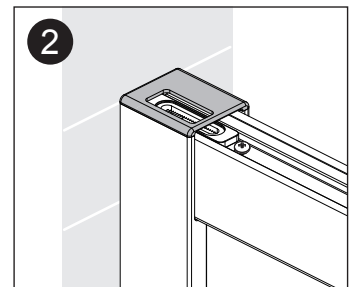
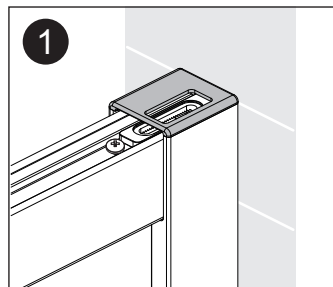
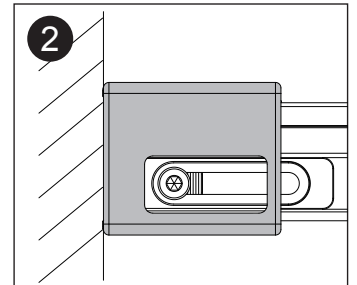
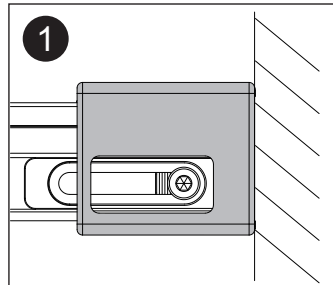
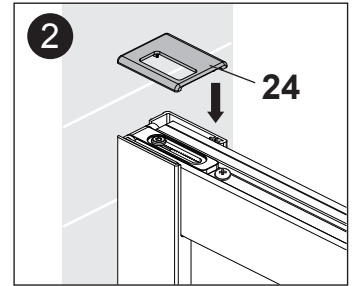
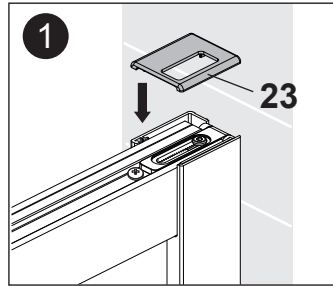
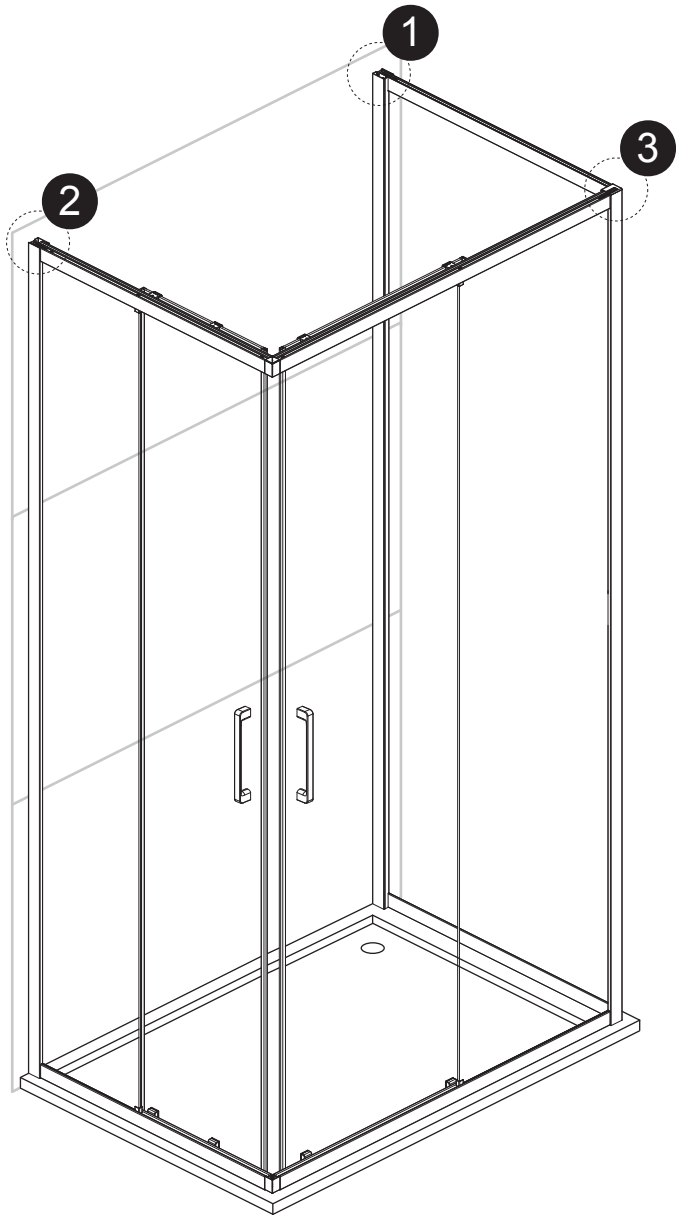

18B

B1

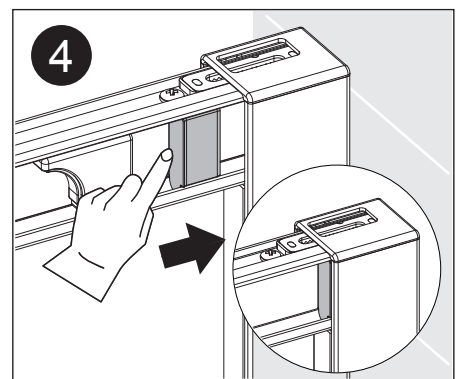
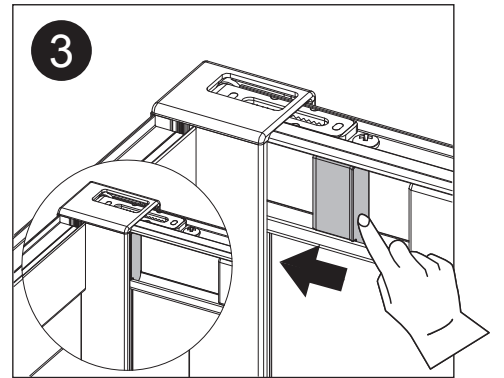
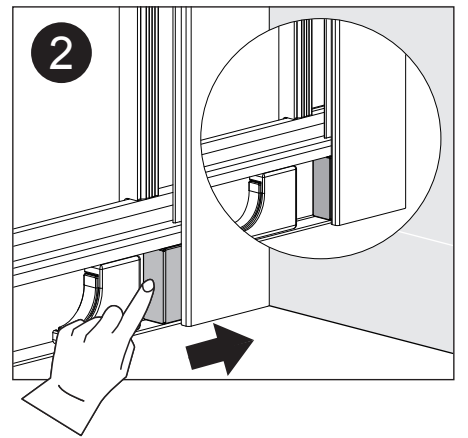
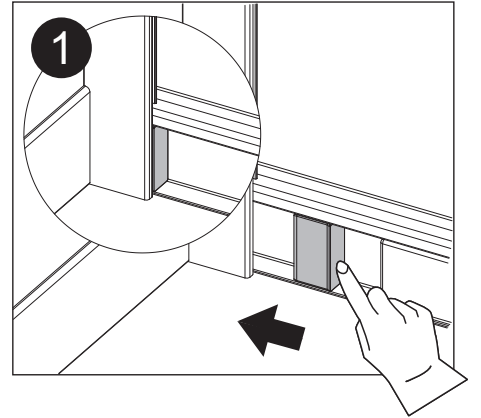
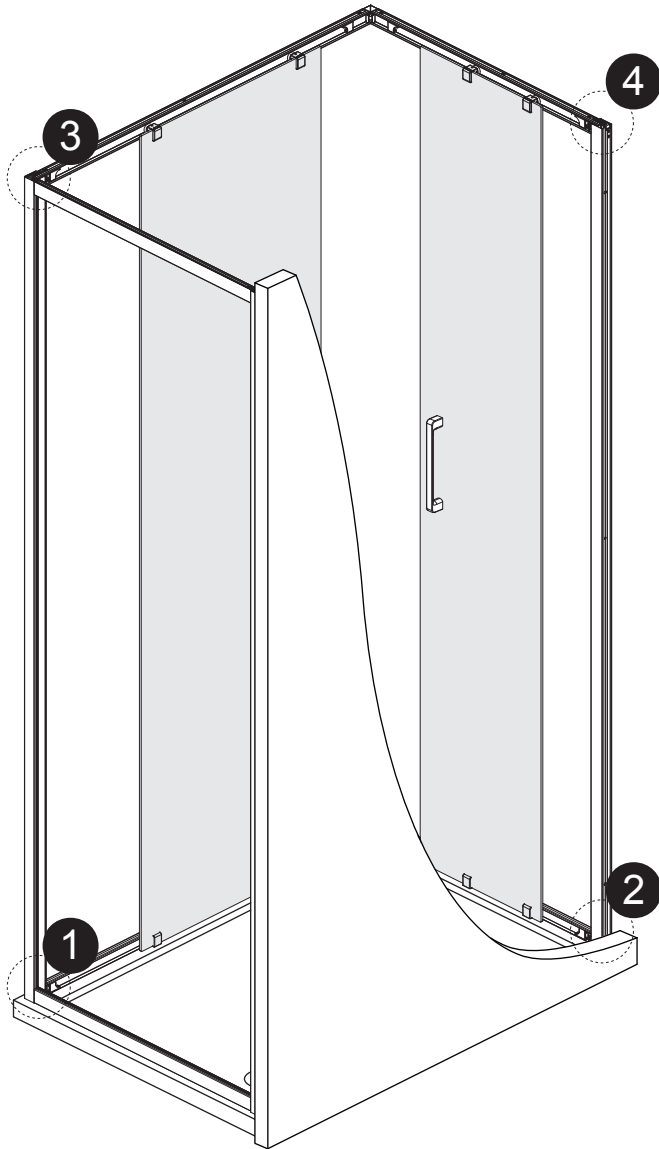

19B

B1

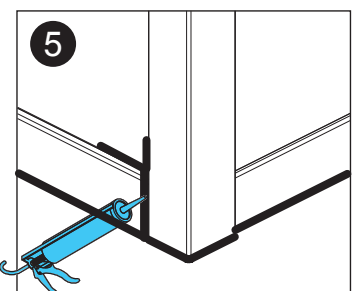
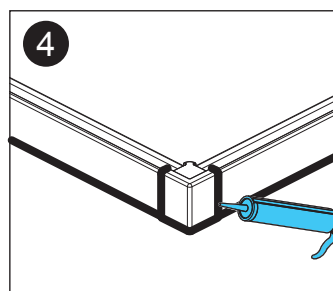
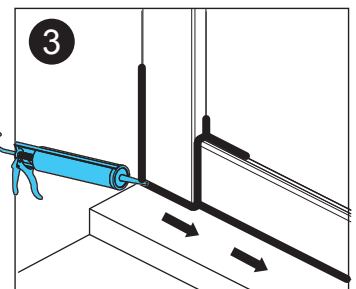
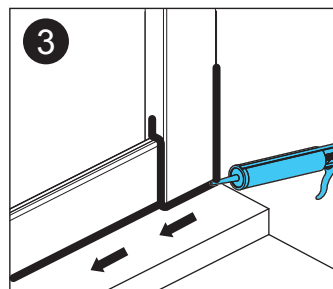
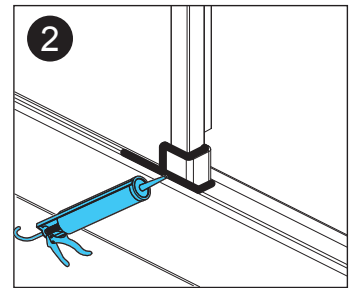
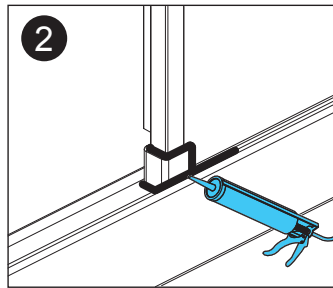
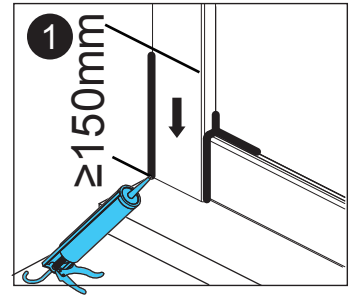
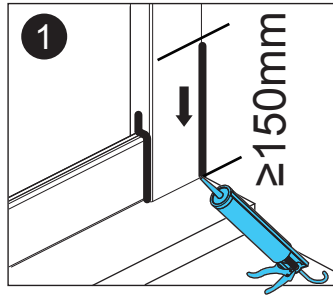
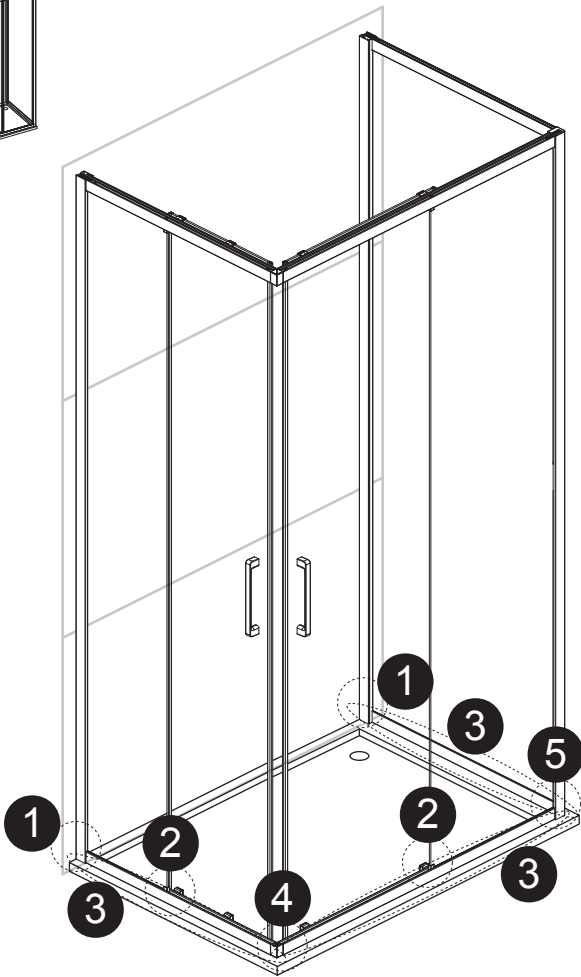

- EN** Do not use the shower enclosure for at least 24 hours in order to allow the silicone sealant to cure fully.
- FR** N'utilisez pas votre douche pendant au moins 24 heures afin de permettre aux joints de silicone de sécher entièrement.
- PL** Po zakończonym montażu, nie używaj brodzika prysznicowego przez co najmniej 24 godziny, aby umożliwić pełne osadzenie się uszczelnacza silikonowego.
- RO** Nu utilizați cab.ina de duș timp de cel puțin 24 pentru a permite izolației de silicon să se usuc complet.
- ES** No use la cabina de la ducha por lo menos 24 para dejar que el sellador de silicón fragüe completamente.
- PT** Não utilize a divisória de chuveiro durante, no mínimo, 24 horas para garantir que o vedante silicone fica totalmente seco.

1A

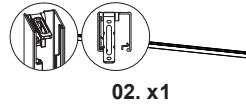
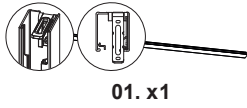
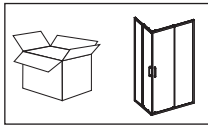

A2



| SIZE (mm) | A(mm) | B(mm) |
|-----------|---------|-----------|
| 700×900 | 675-695 | 875-895 |
| 700×1000 | | 975-995 |
| 700×1200 | | 1175-1195 |

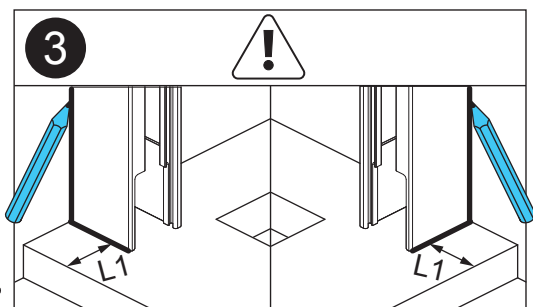
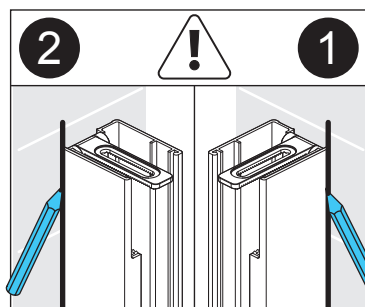
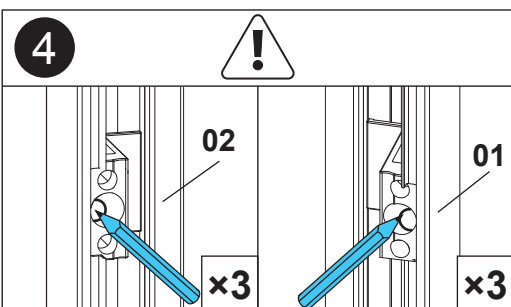
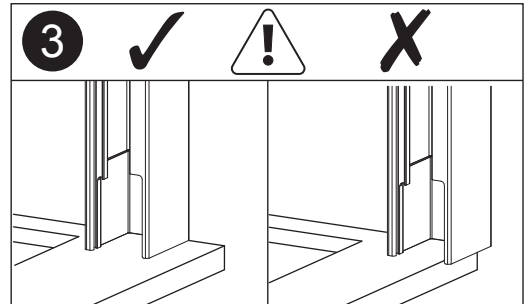
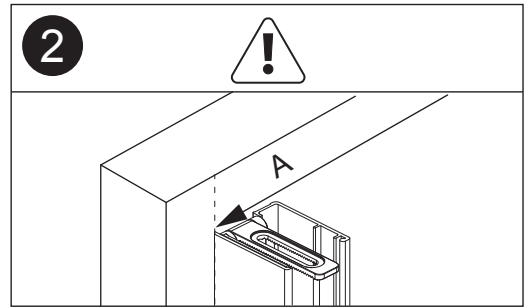
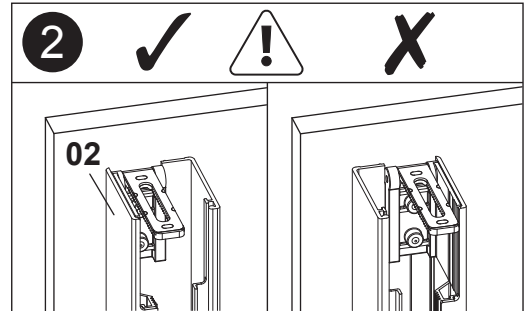
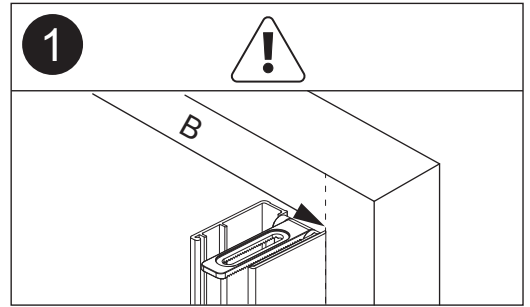
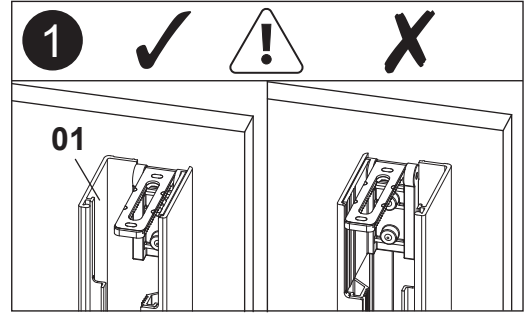
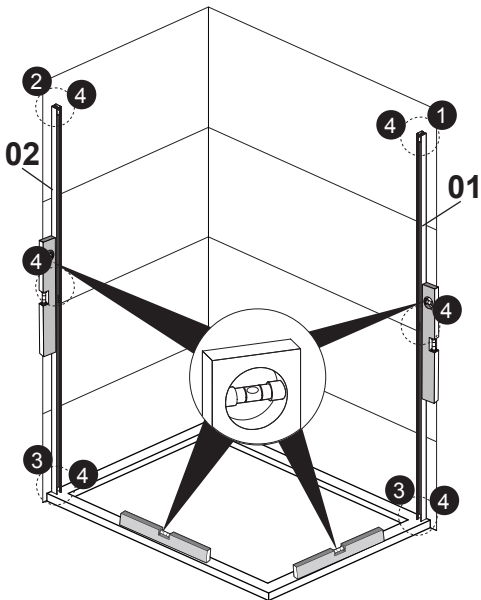
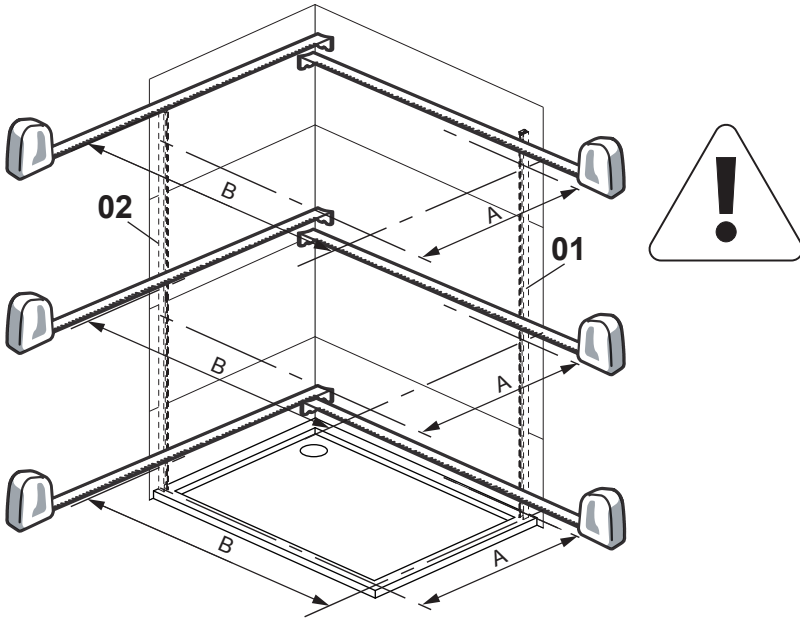

2A

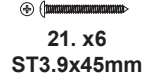
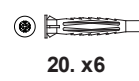
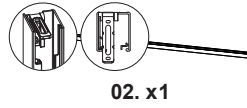
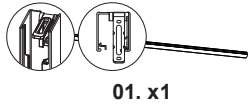
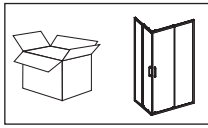

A2

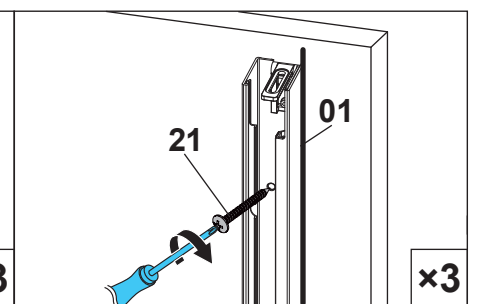
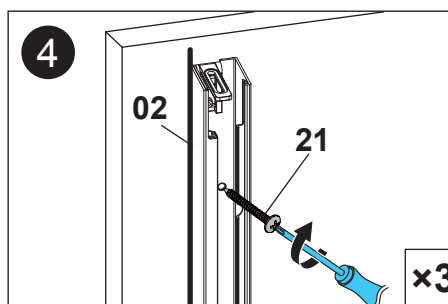
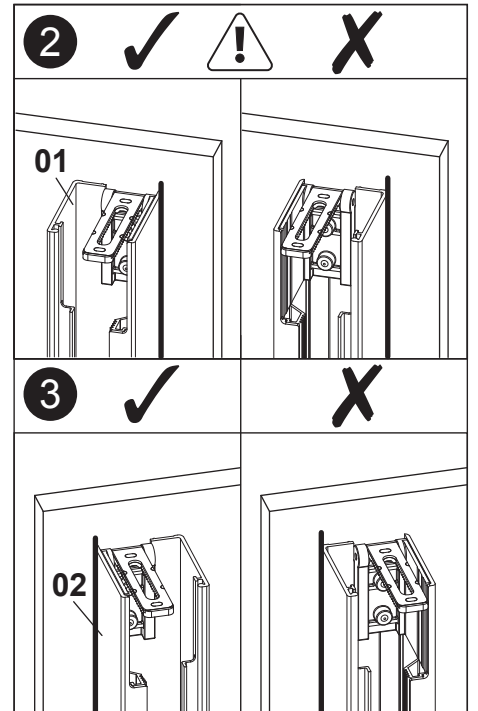
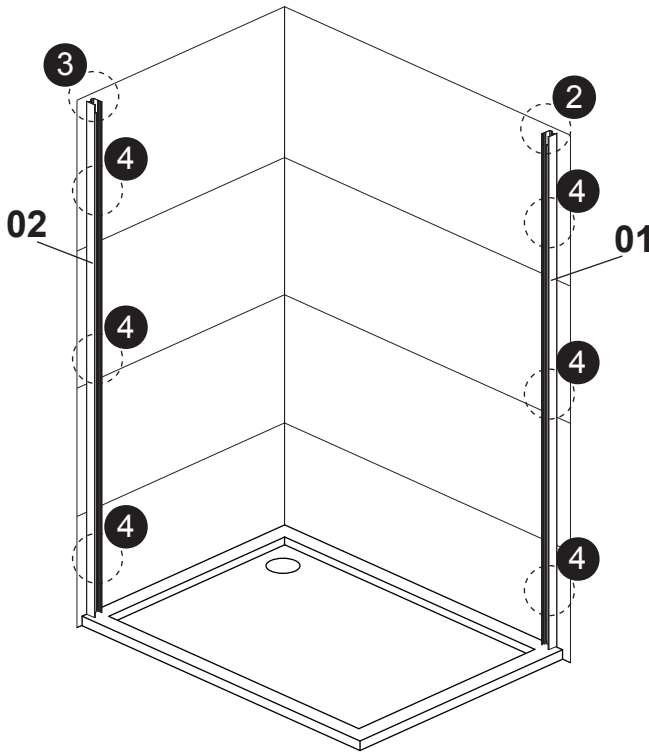
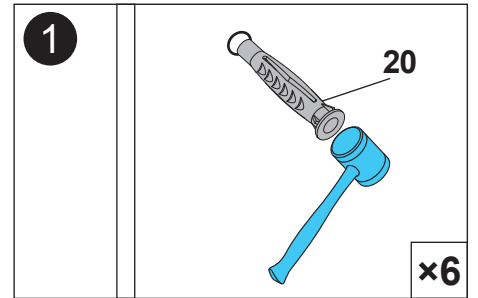
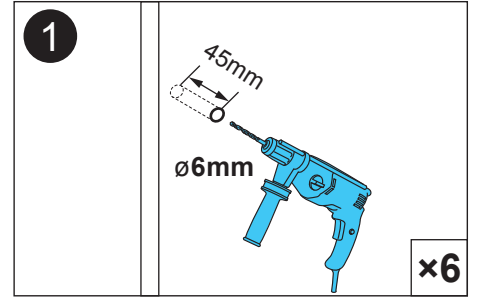
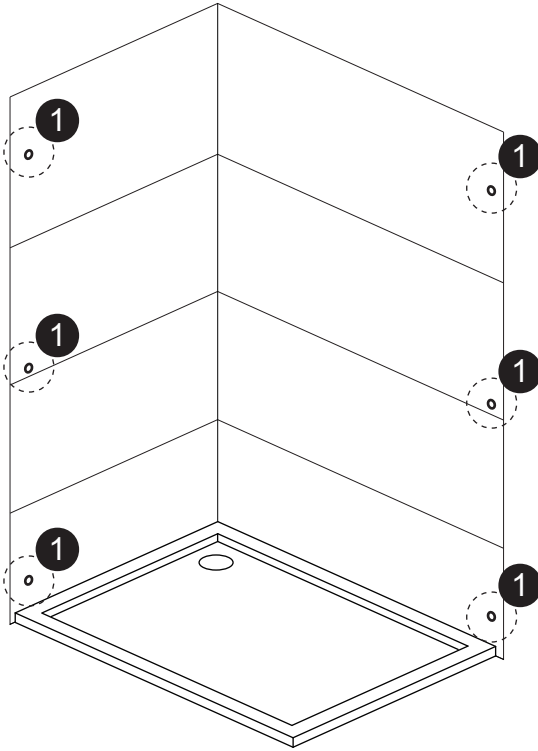

3A

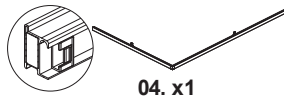
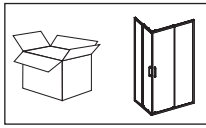

04. x1

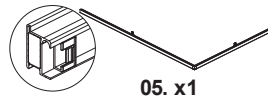

05. x1

A2

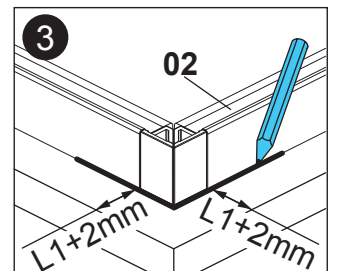
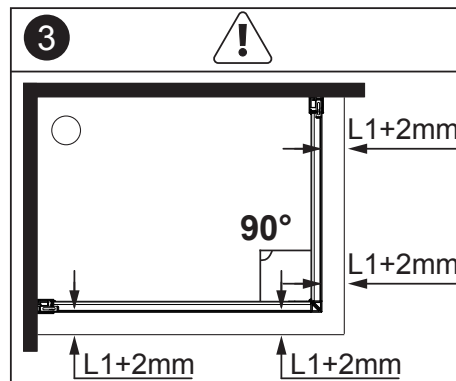
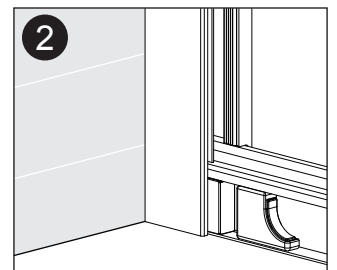
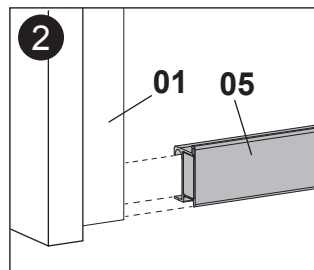
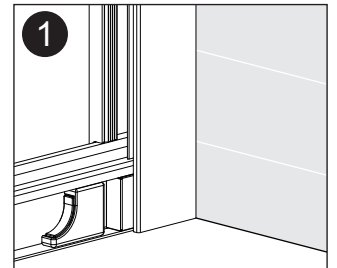
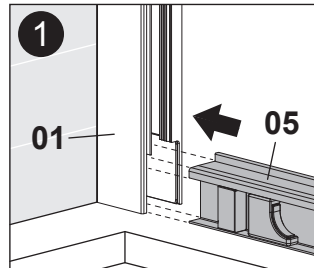
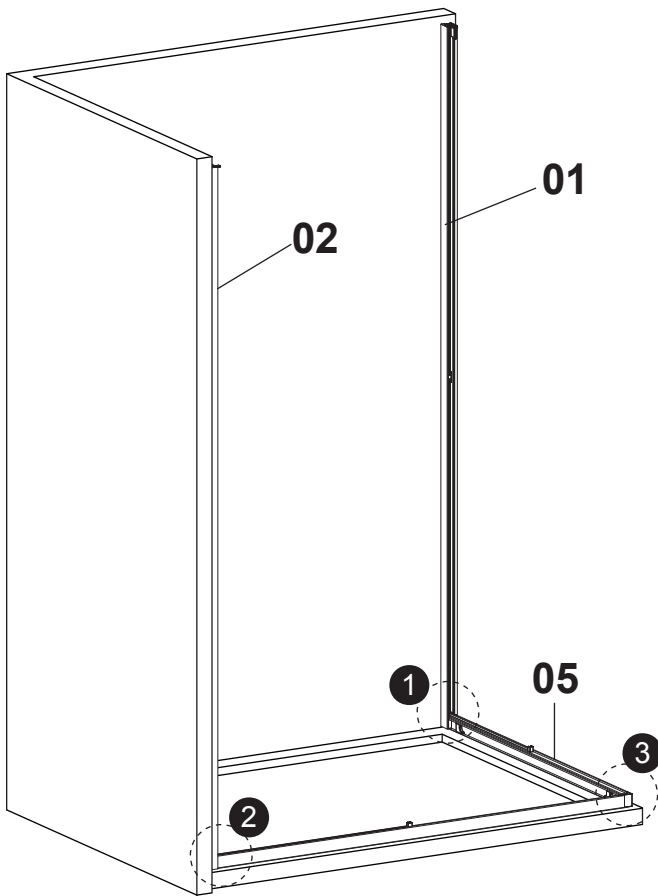
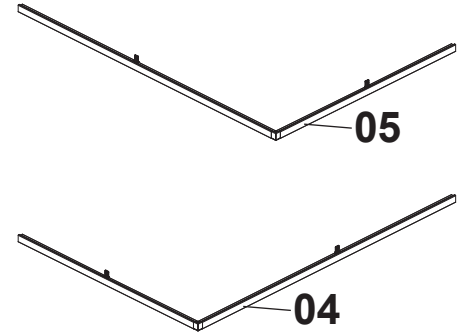
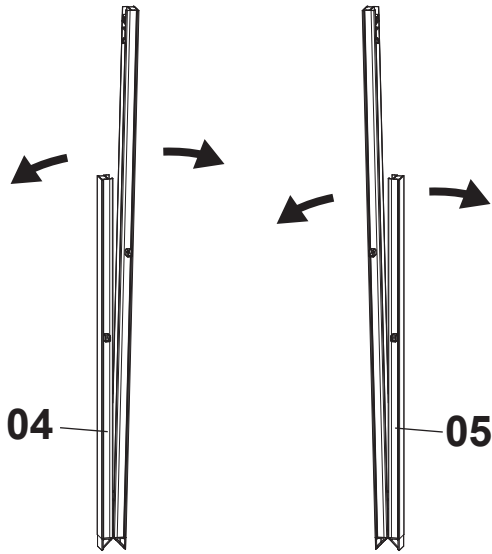

4A

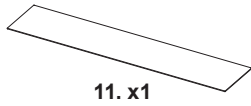
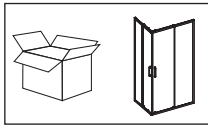

11. x1

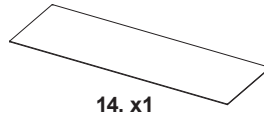

14. x1



50-1. x2



50-2. x2

A2

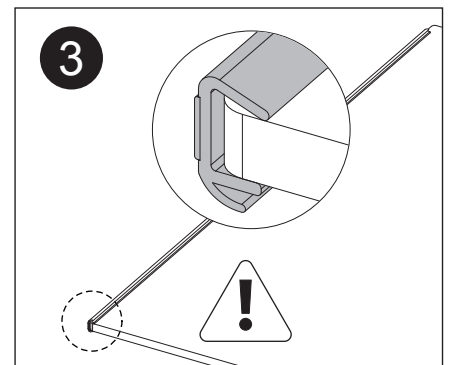
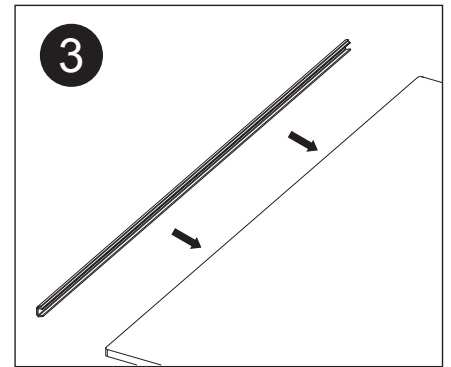
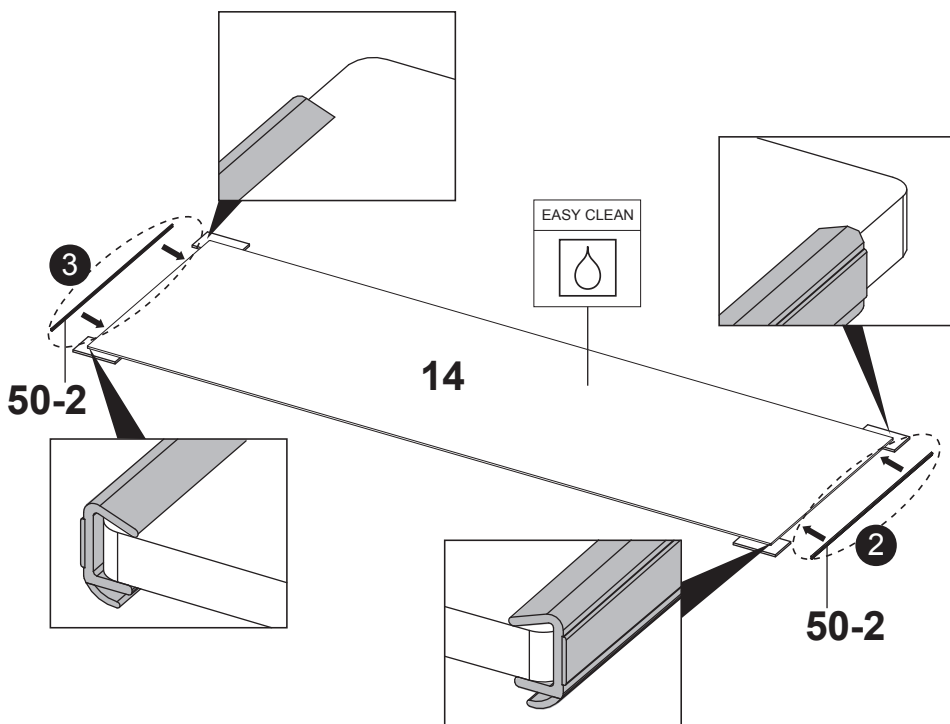
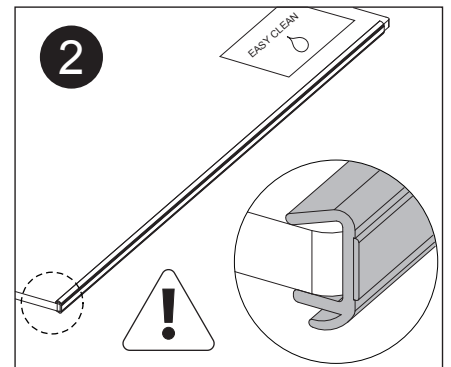
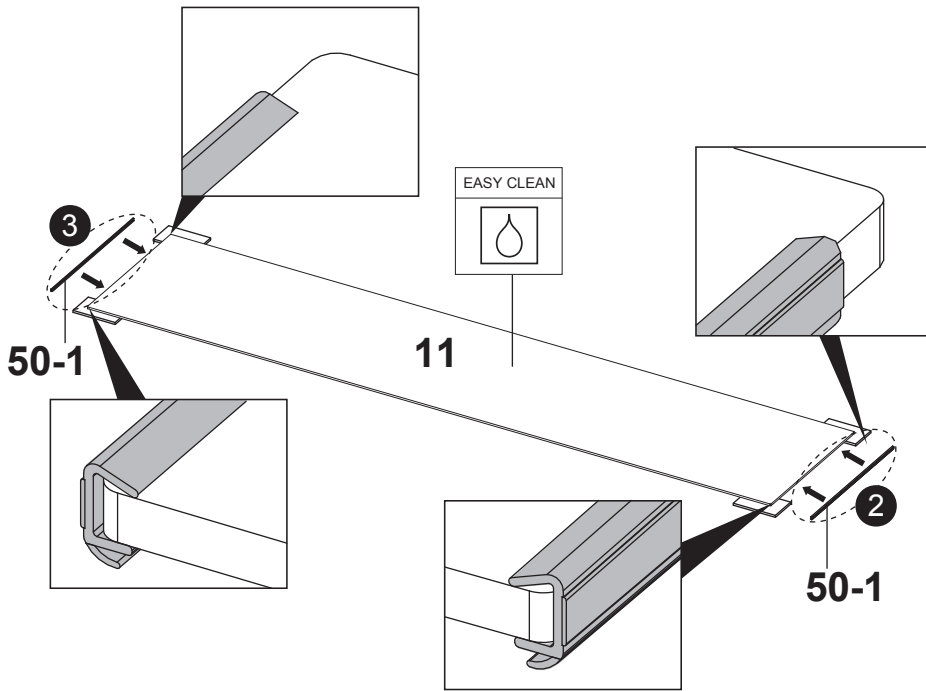
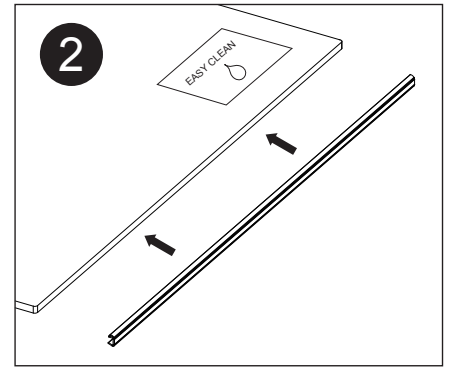
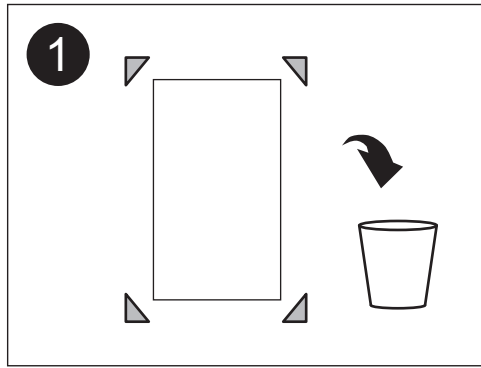

5A

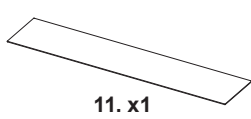
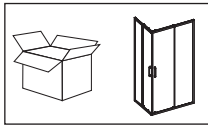

11. x1

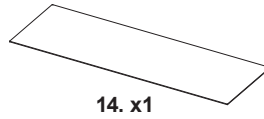

14. x1

A2

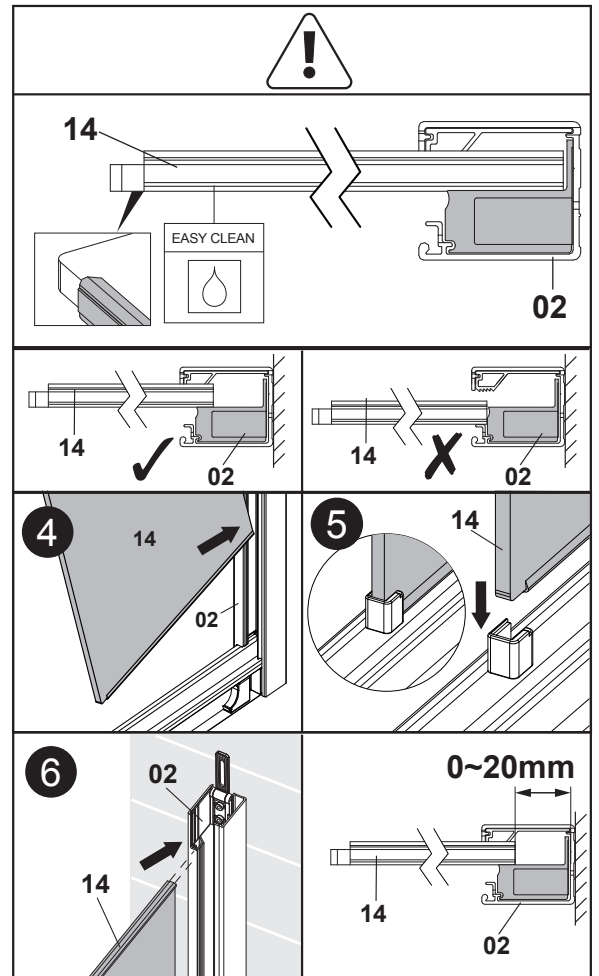
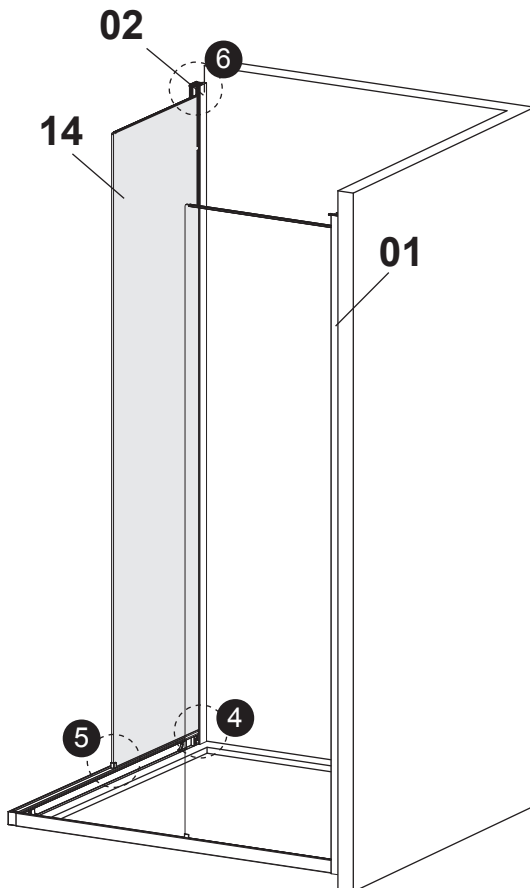
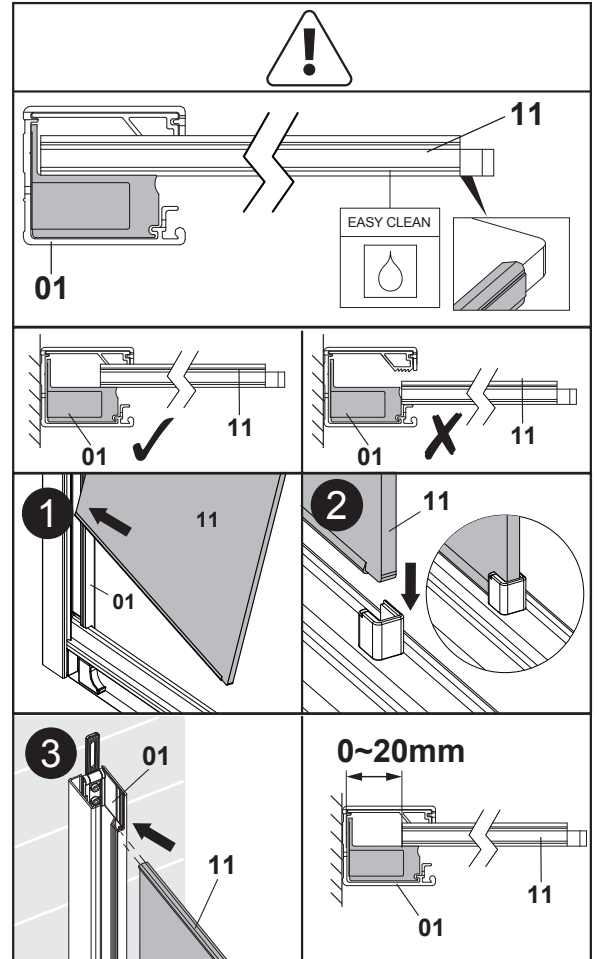
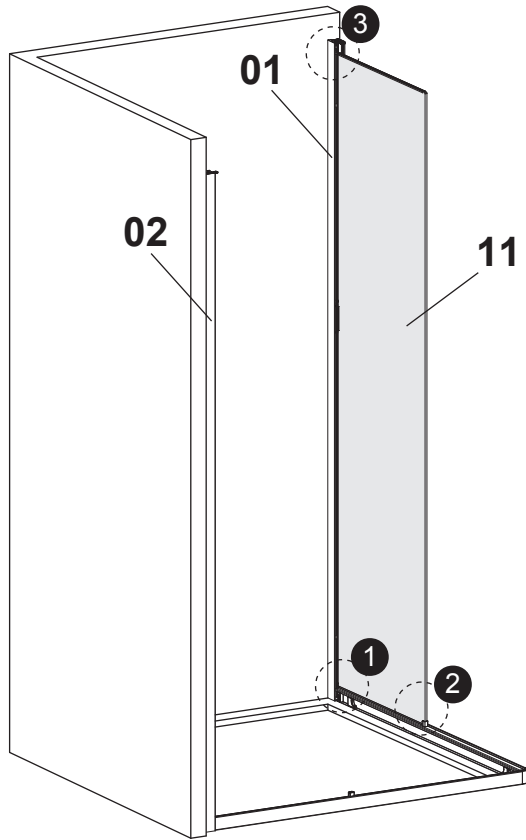

6A

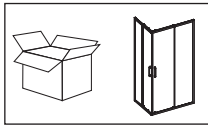

04. x1



22. x2
M4x10mm

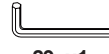

29. x1
2.5mm

A2

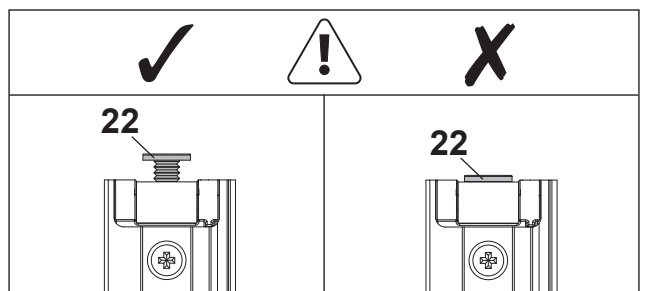
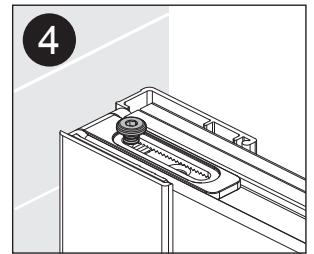
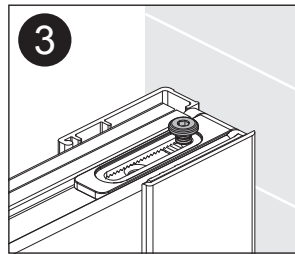
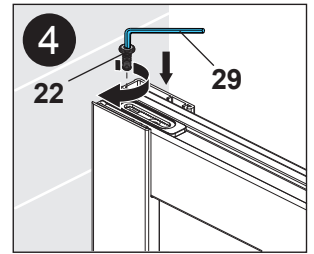
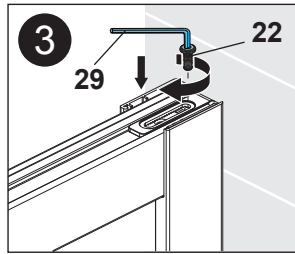
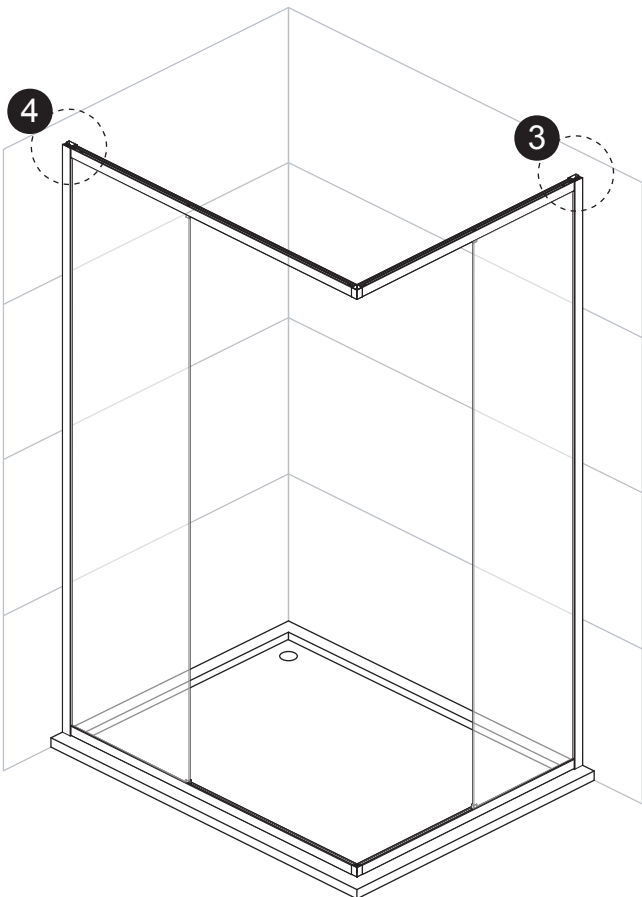
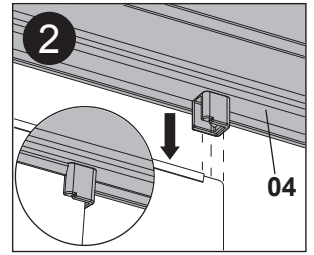
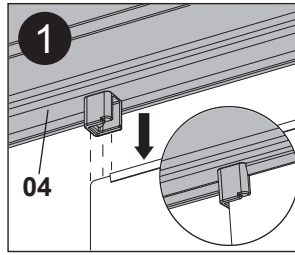
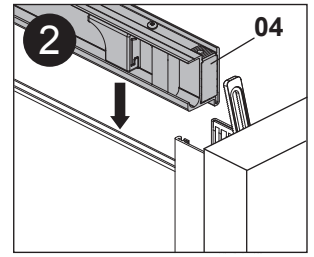
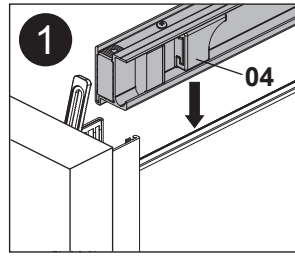
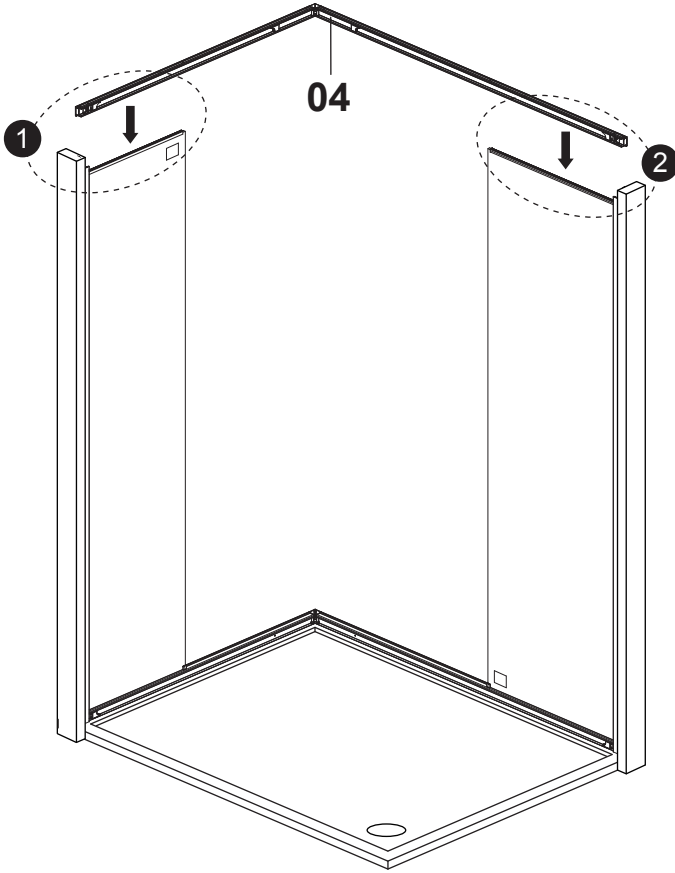

7A

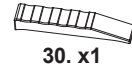
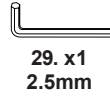
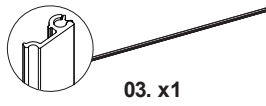
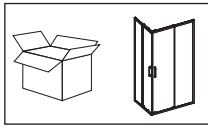

A2

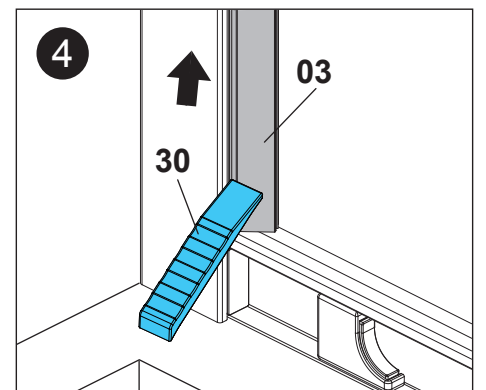
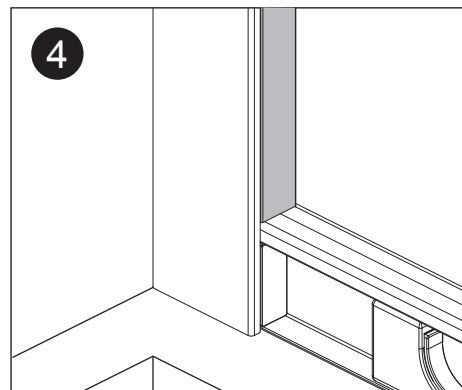
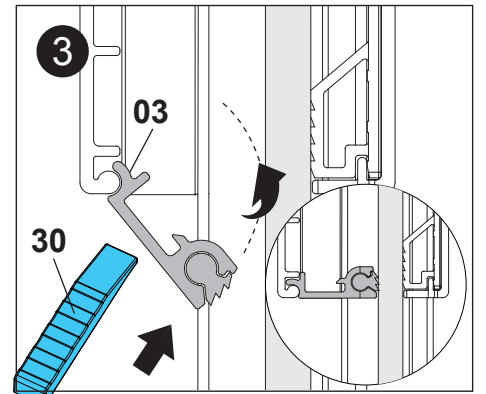
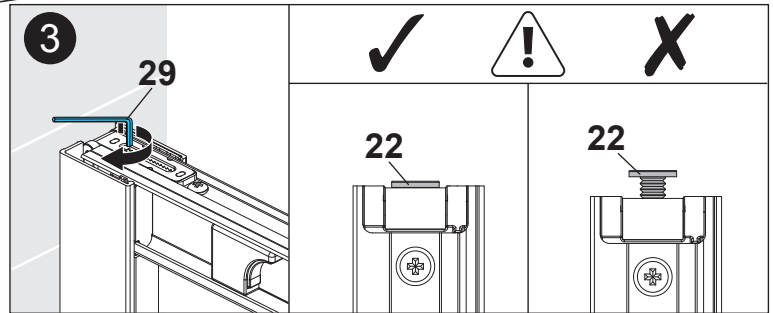
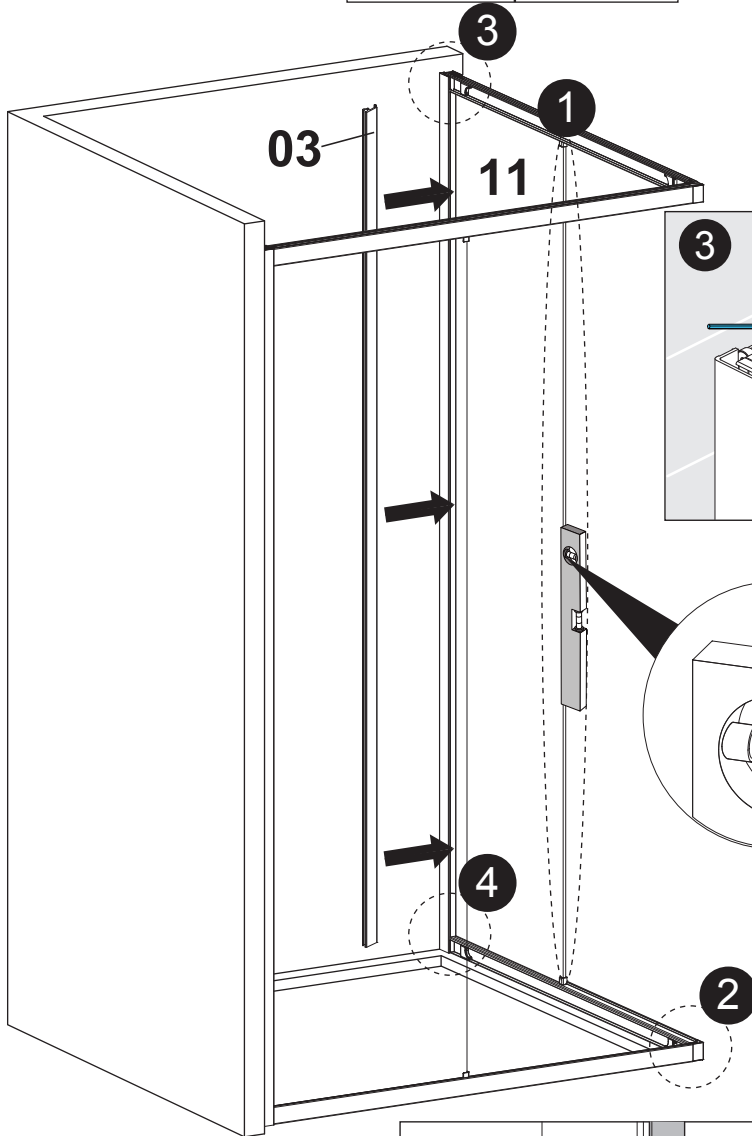
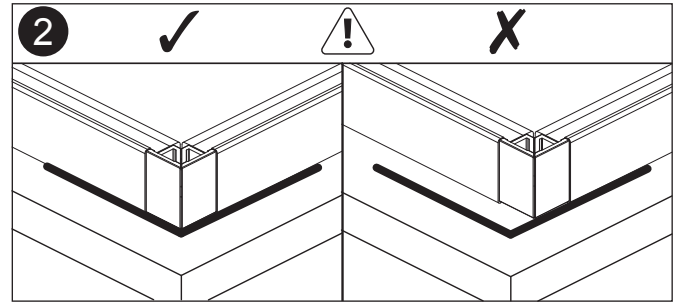
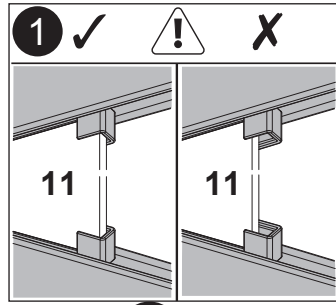

8A

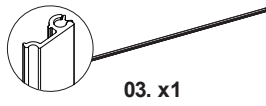
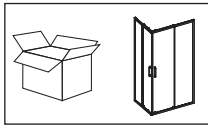

03. x1

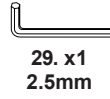

29. x1
2.5mm



30. x1

A2

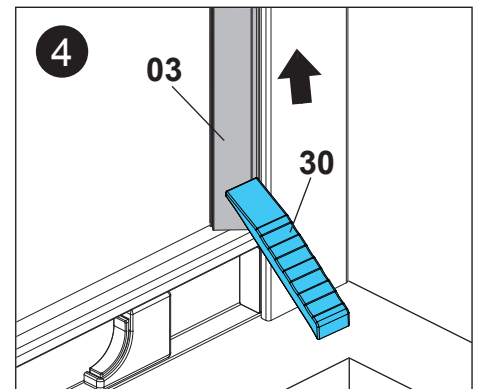
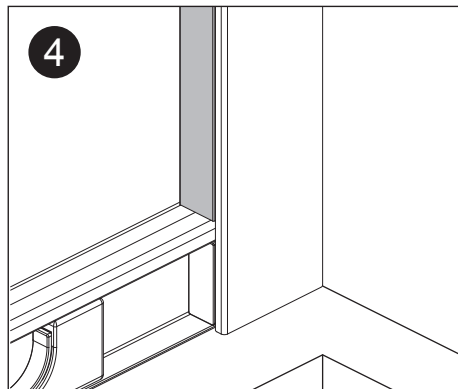
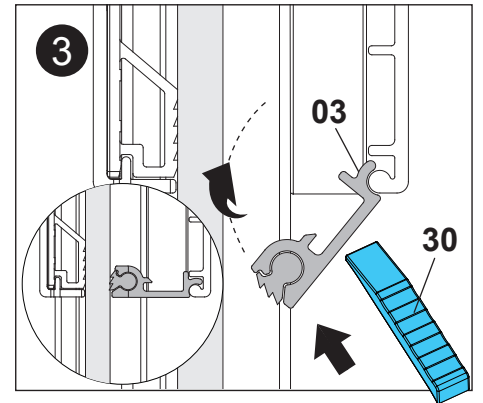
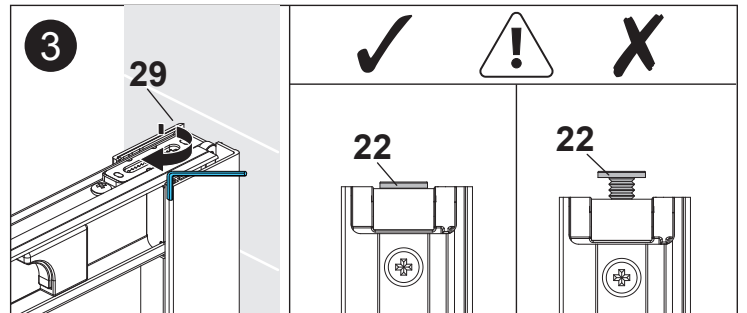
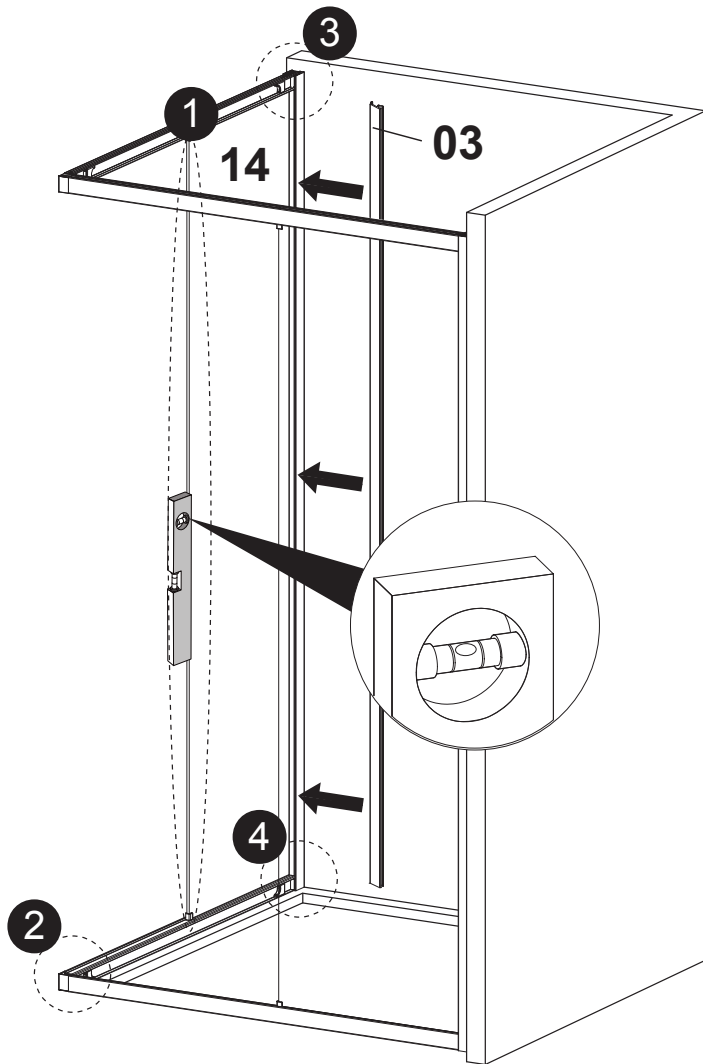
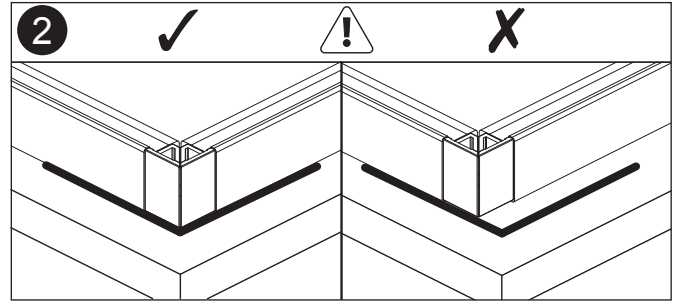
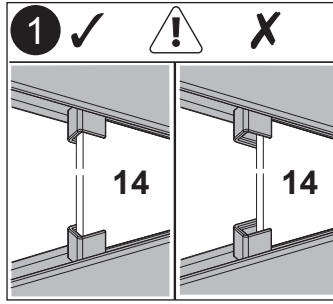

9A

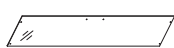
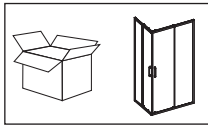

12. x1

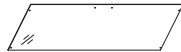

13. x1



26. x4



27. x4



29. x1
2.5mm

A2

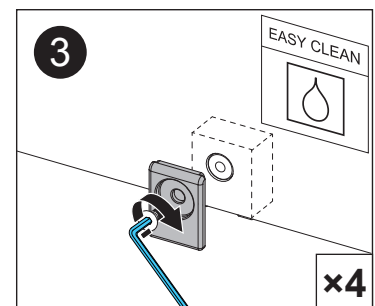
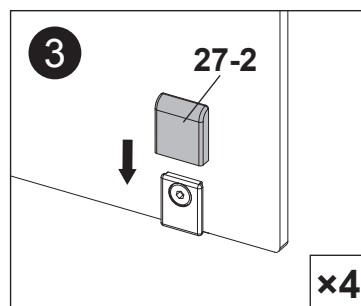
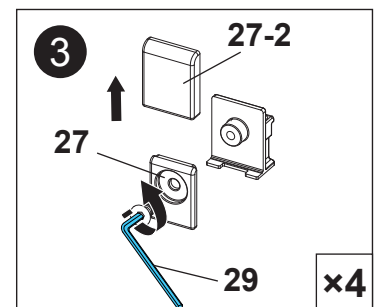
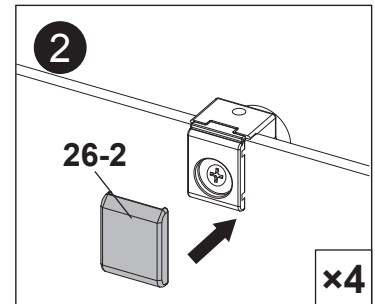
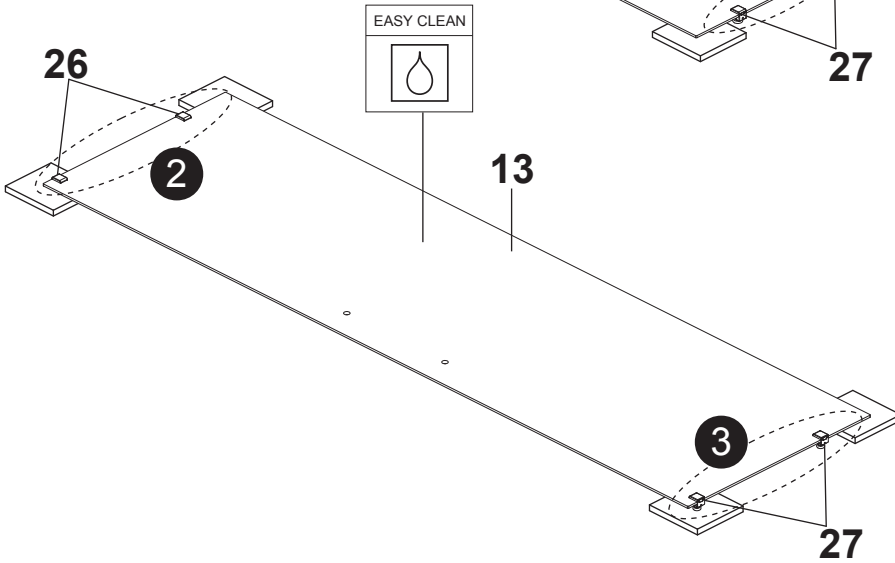
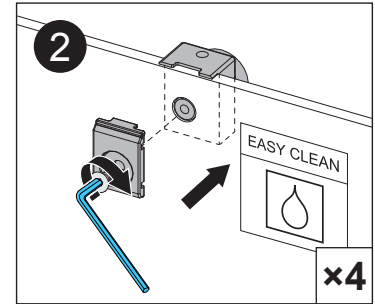
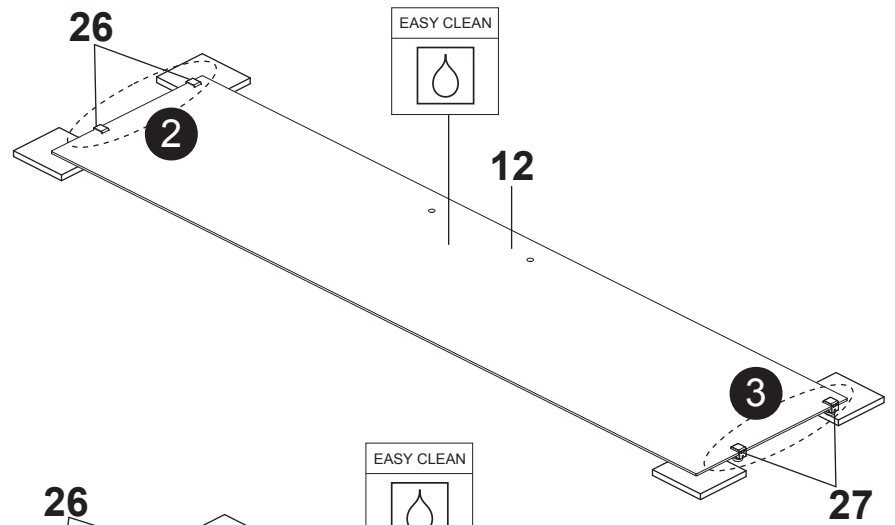
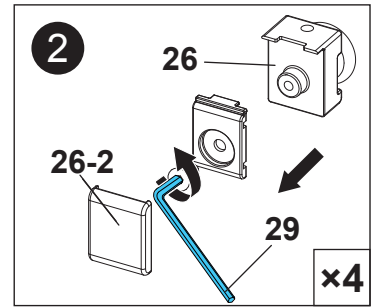
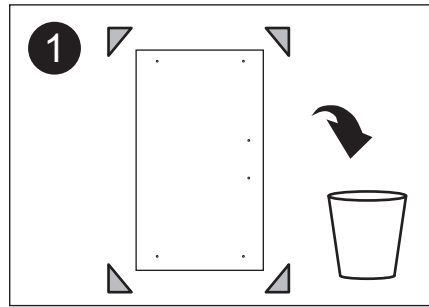

10A

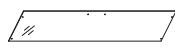
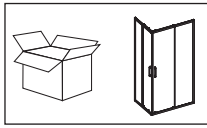

12. x1

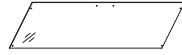

13. x1

A2

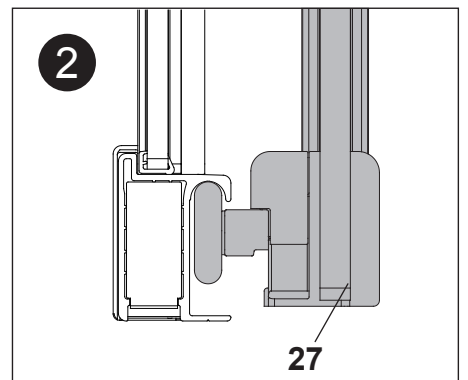
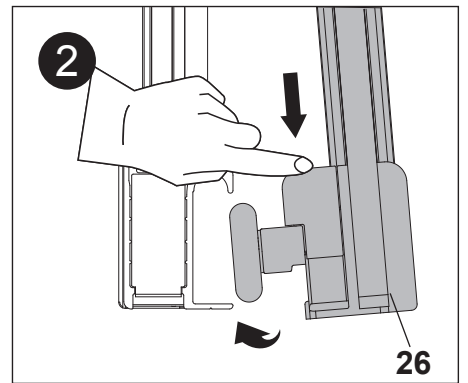
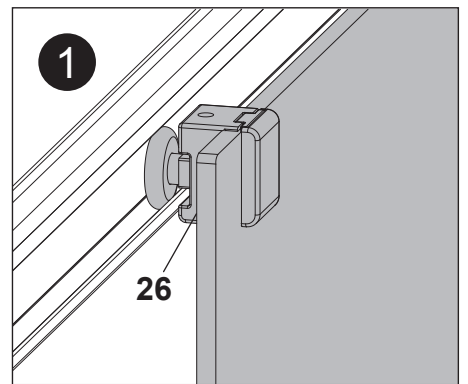
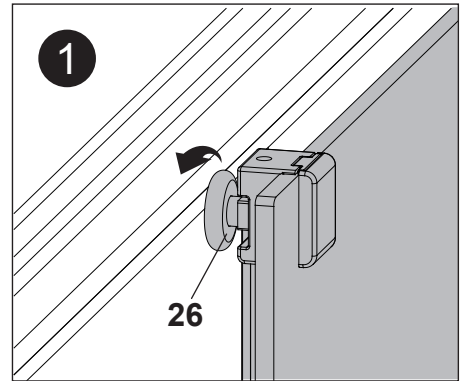
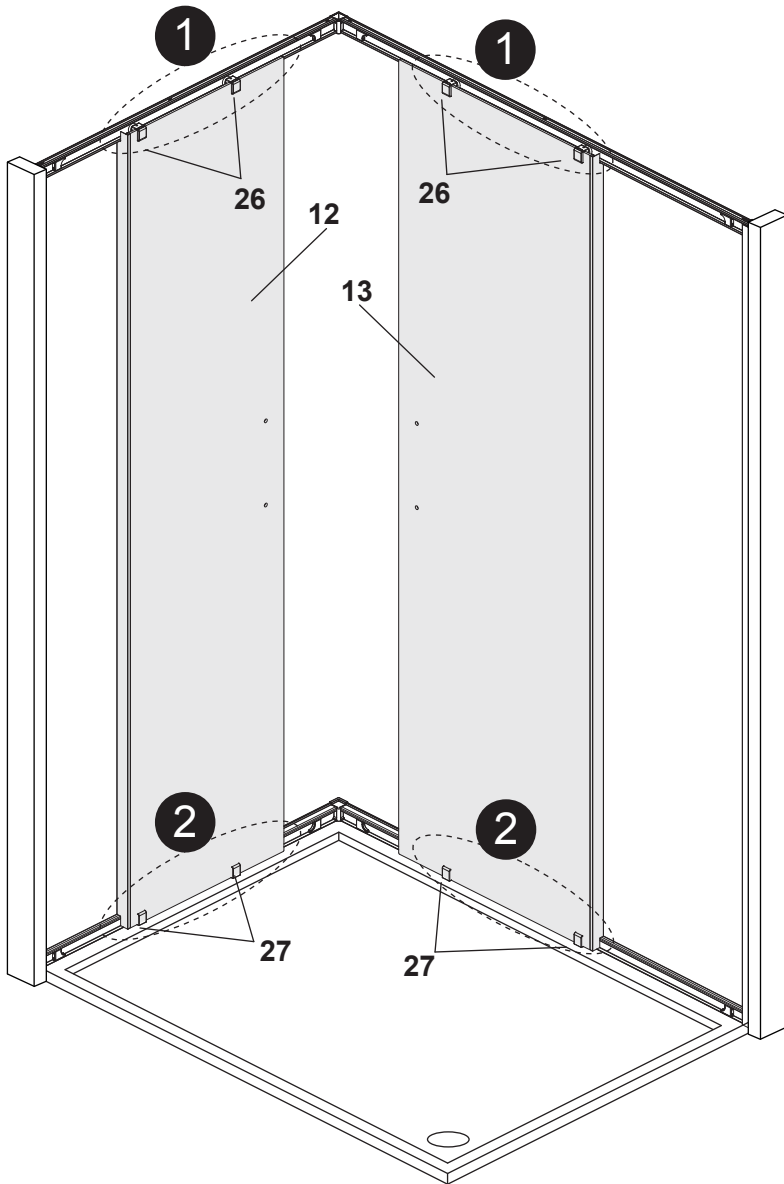

11A

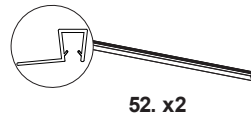
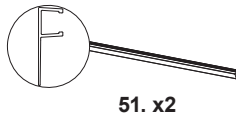
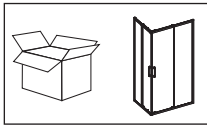

A2

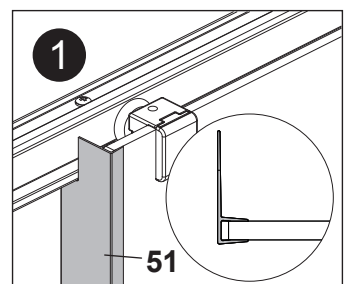
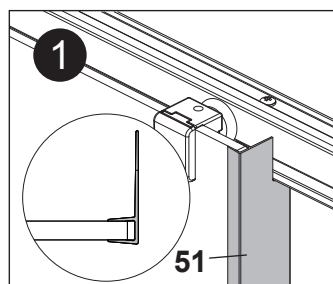
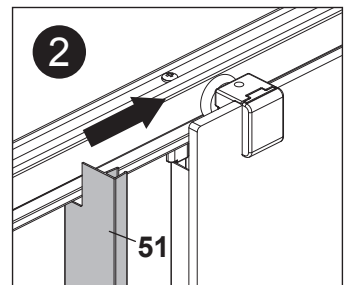
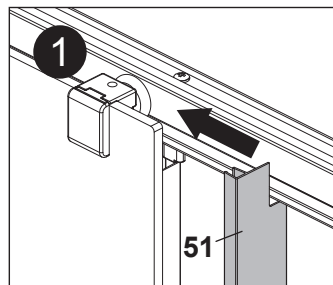
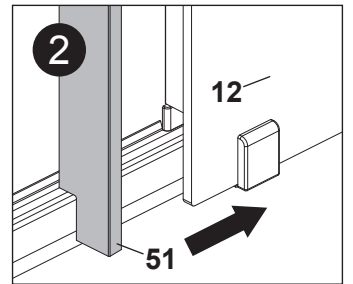
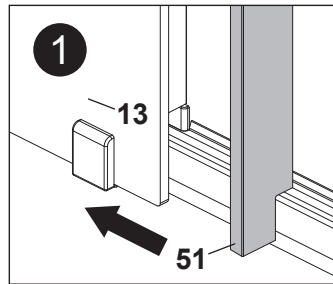
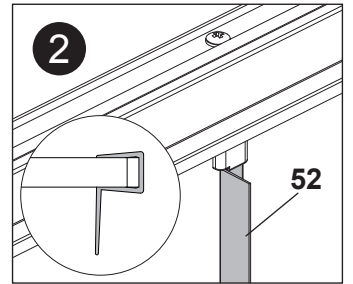
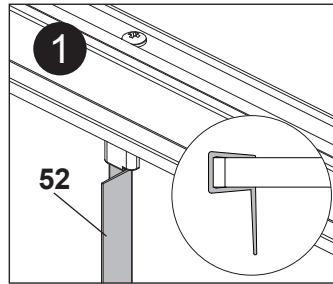
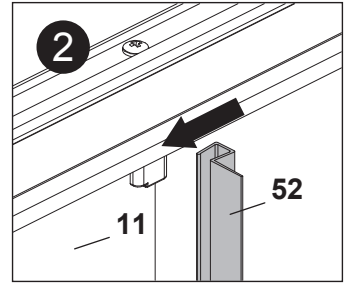
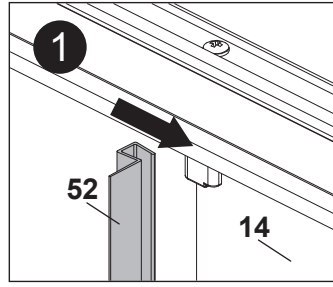
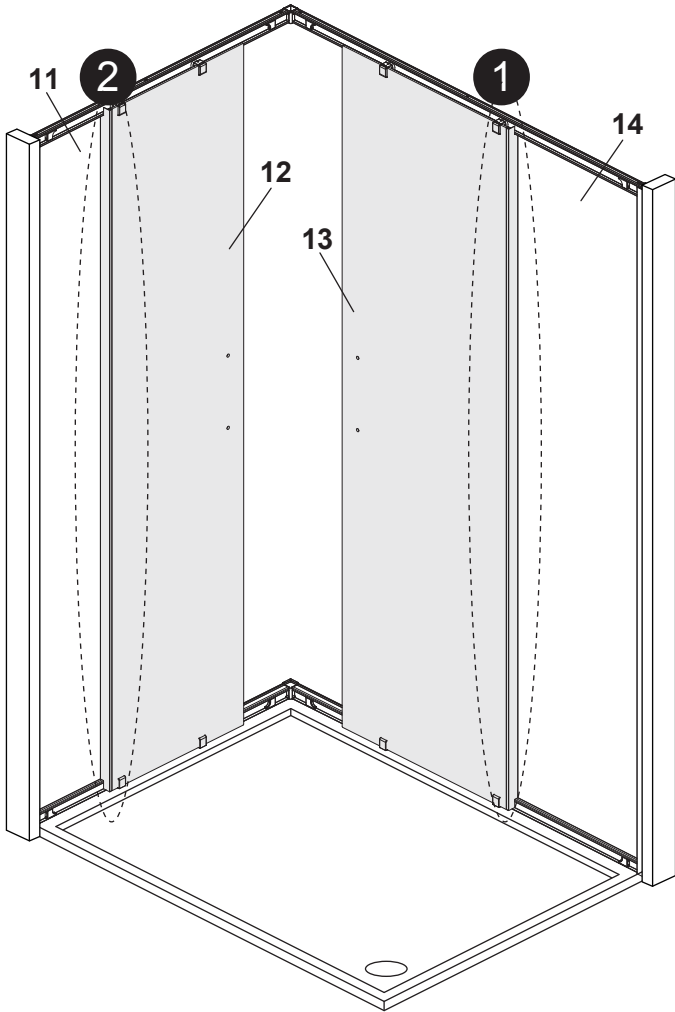

12A

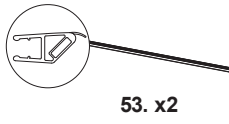
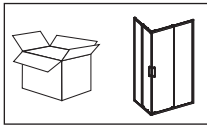

53. x2



29. x1
2.5mm



30. x1

A2

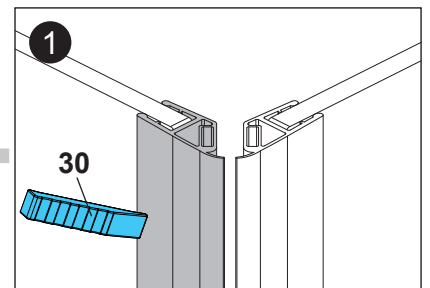
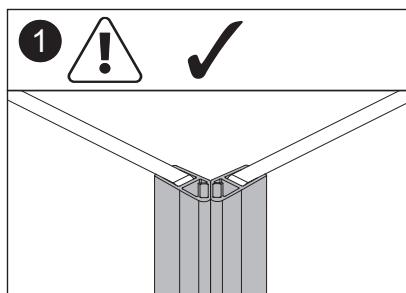
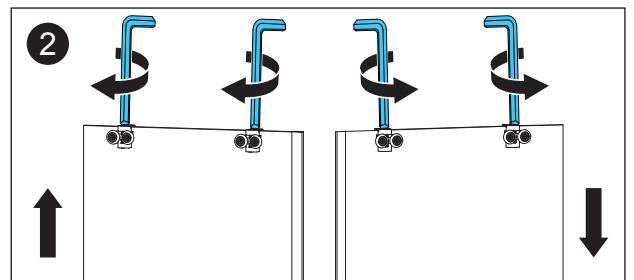
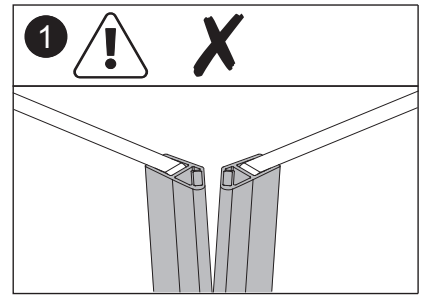
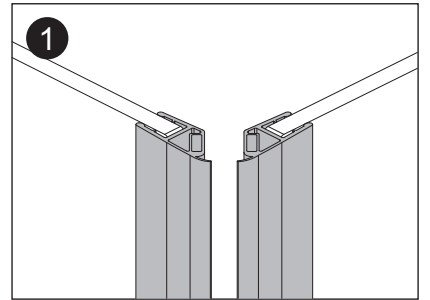
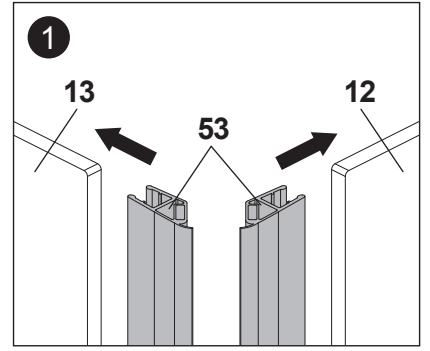
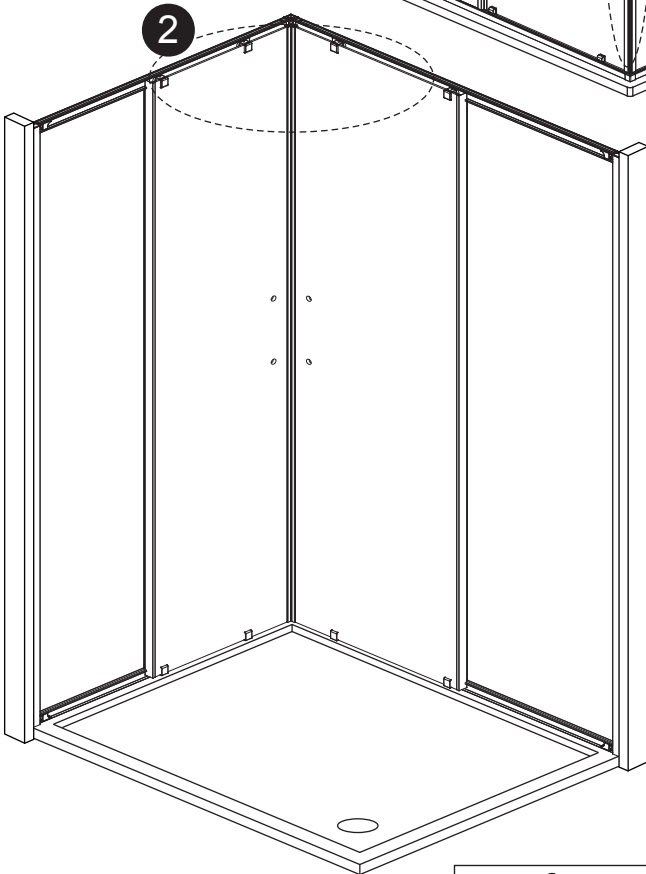
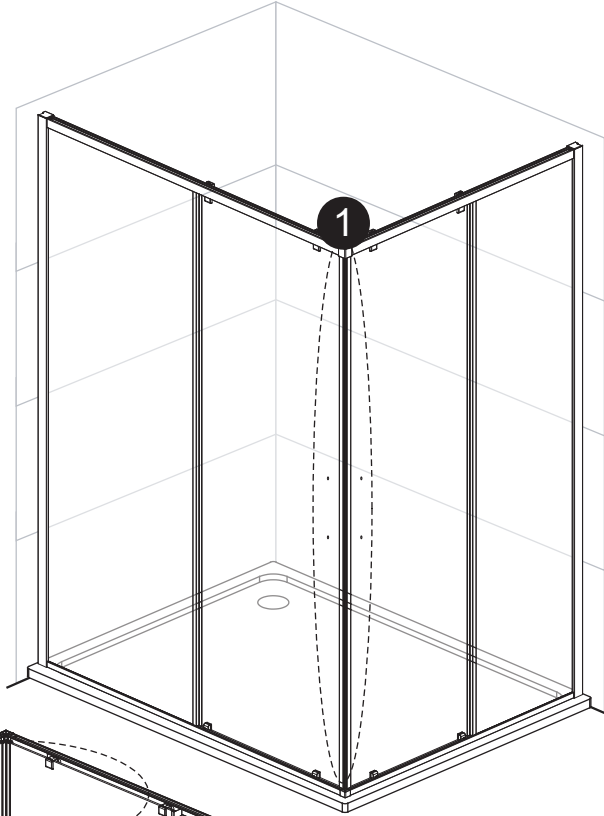

13A

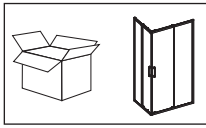

28. x2

A2

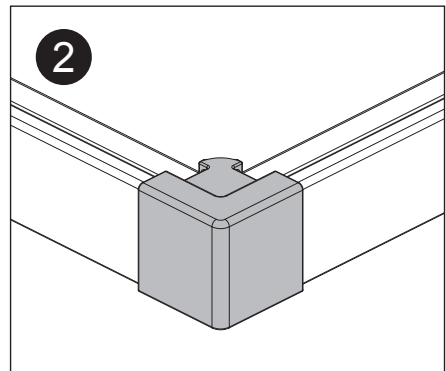
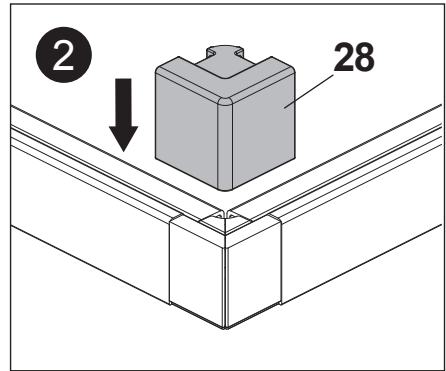
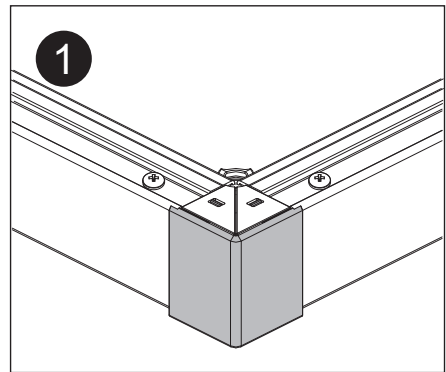
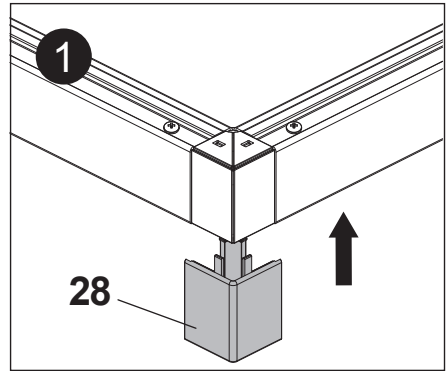
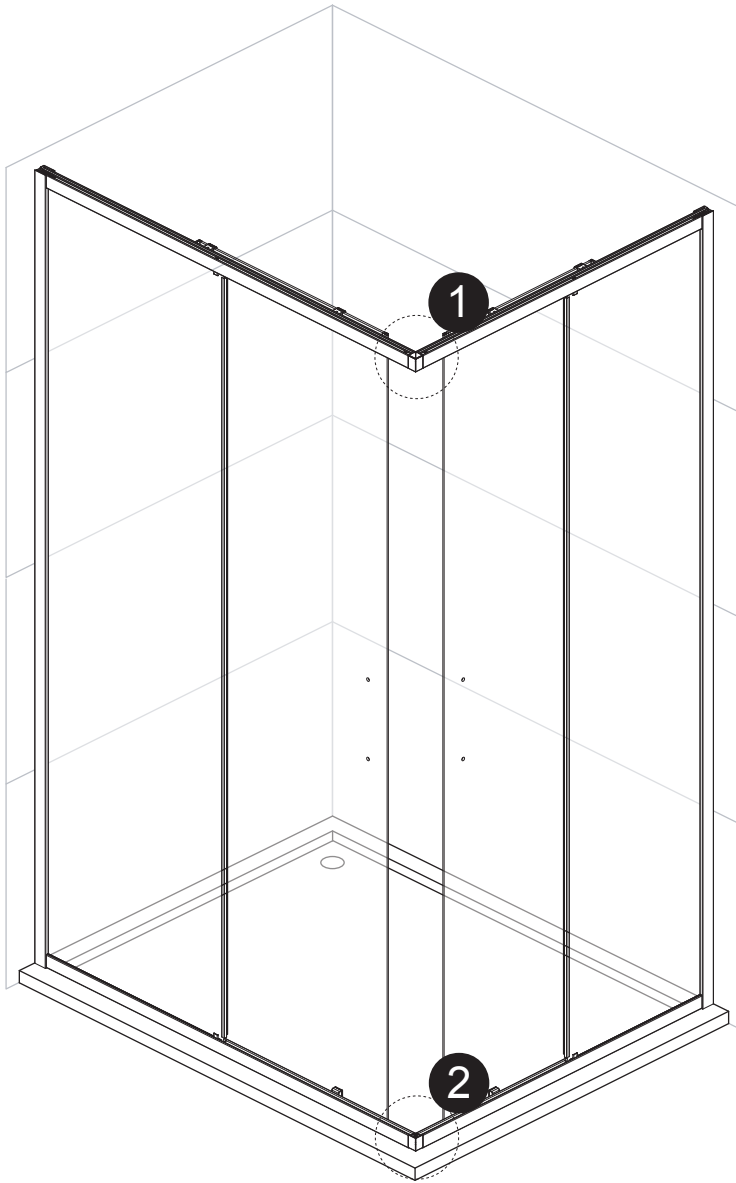

14A

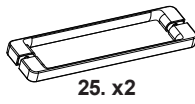
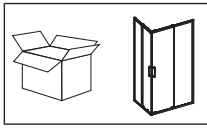

A2

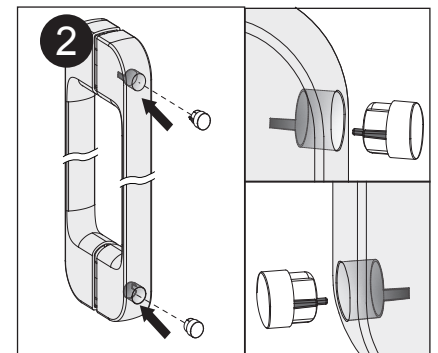
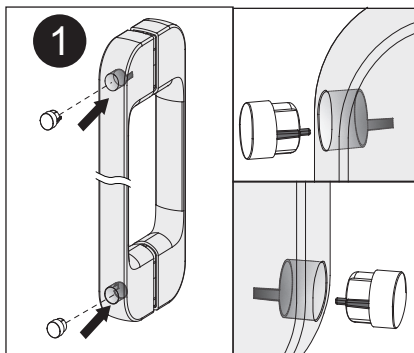
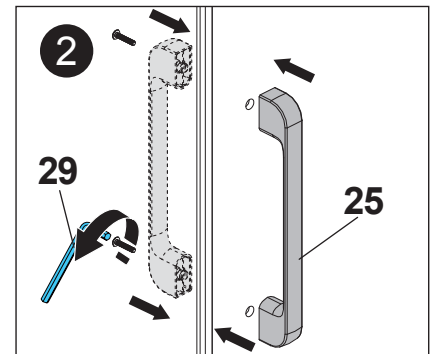
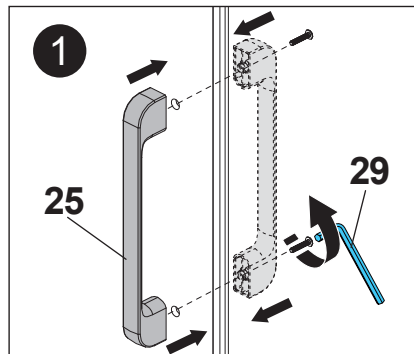
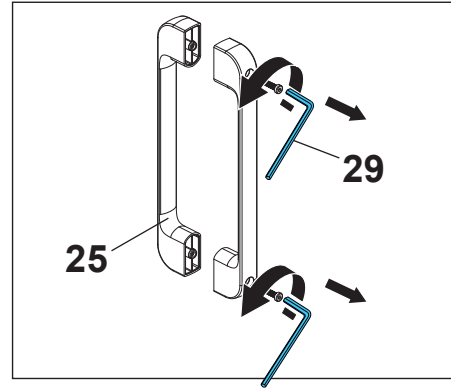

15A

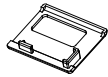
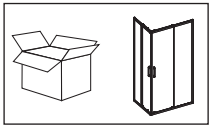

23. x1

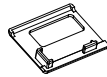

24. x1

A2

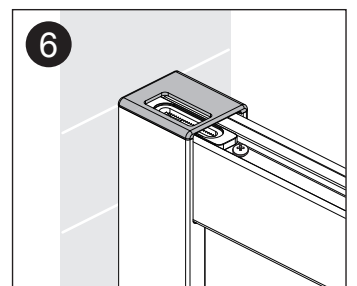
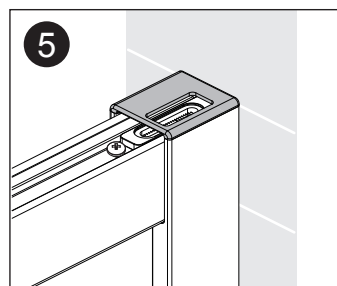
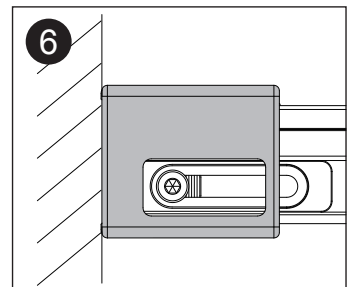
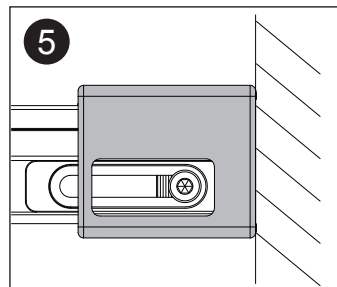
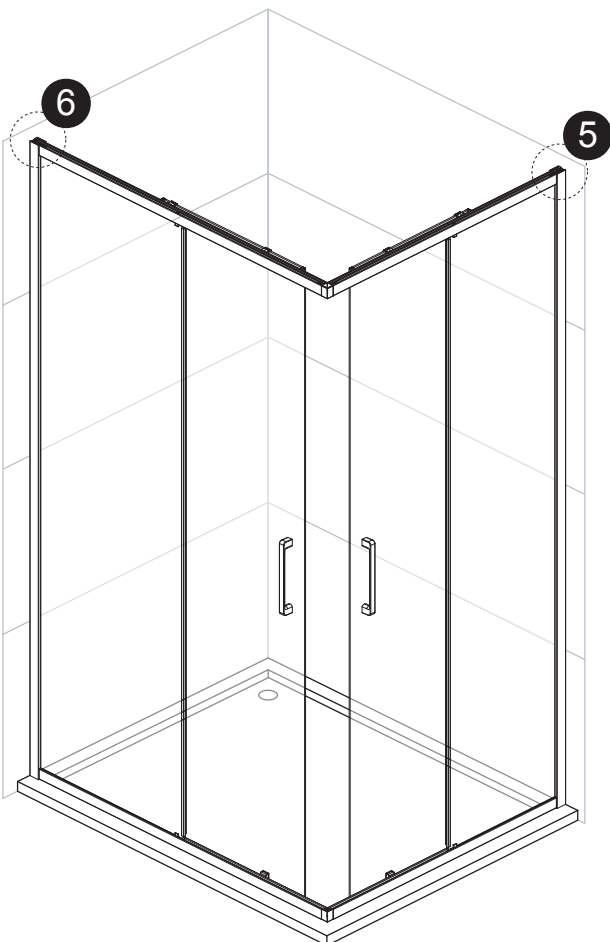
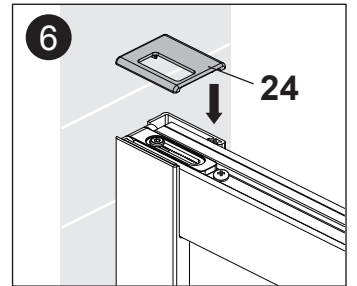
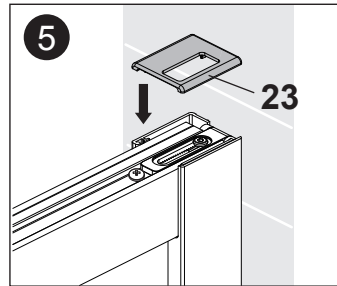
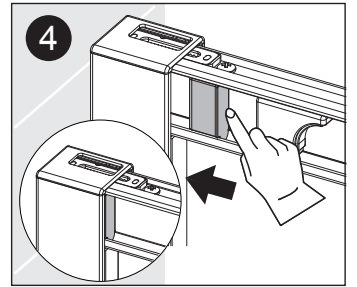
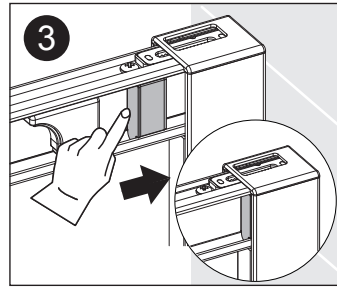
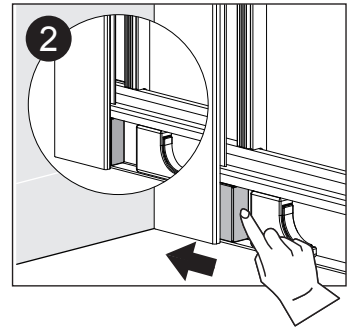
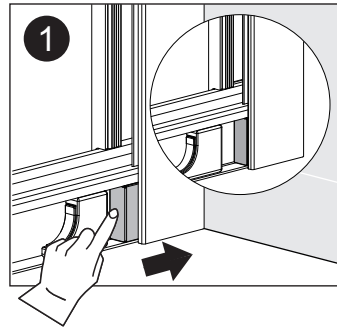
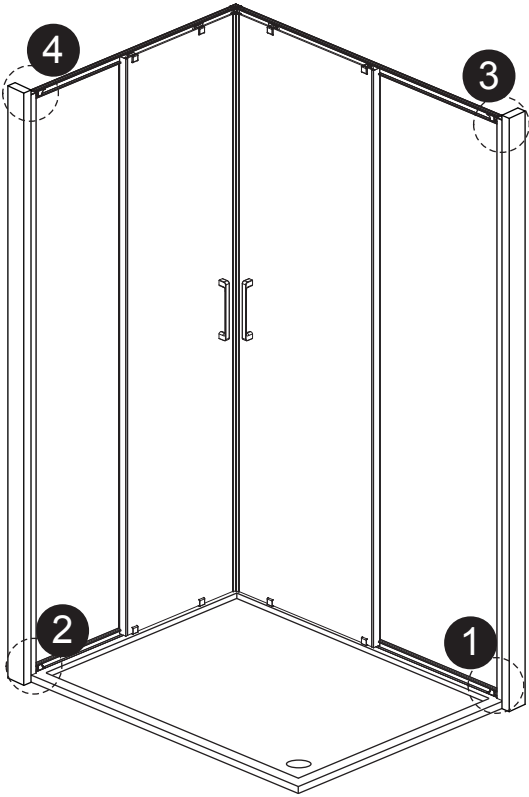

16A

A2

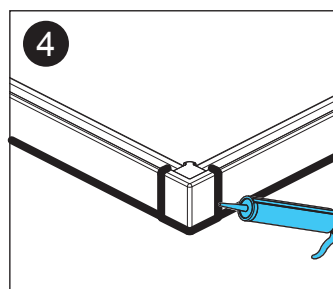
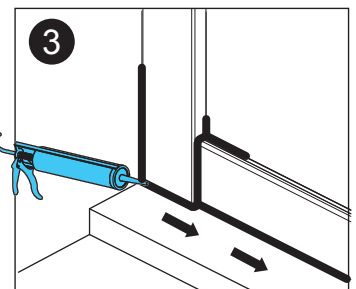
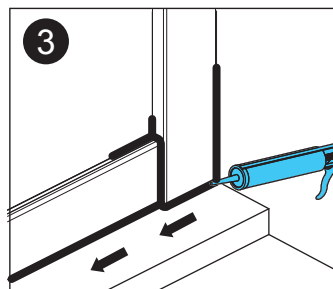
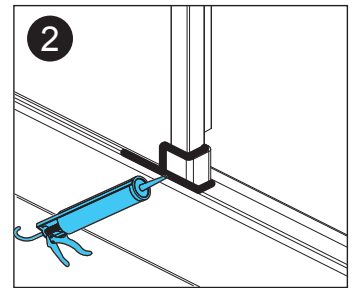
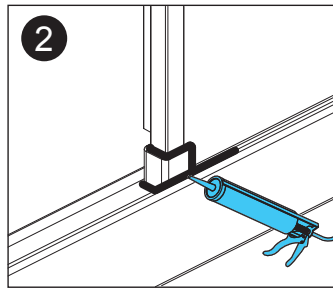
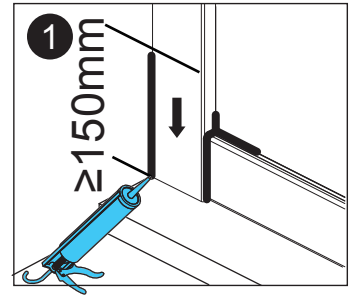
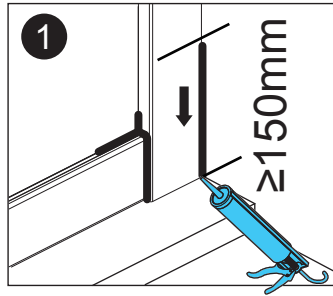

- EN** Do not use the shower enclosure for at least 24 hours in order to allow the silicone sealant to cure fully.
- FR** N'utilisez pas votre douche pendant au moins 24 heures afin de permettre aux joints de silicone de sécher entièrement.
- PL** Po zakończonym montażu, nie używaj brodzika prysznicowego przez co najmniej 24 godziny, aby umożliwić pełne osadzenie się uszczelnacza silikonowego.
- RO** Nu utilizați cab.ina de duș timp de cel puțin 24 pentru a permite izolației de silicon să se usuc complet.
- ES** No use la cabina de la ducha por lo menos 24 para dejar que el sellador de silicon se fragüe completamente.
- PT** Não utilize a divisória de chuveiro durante, no mínimo, 24 horas para garantir que o vedante silicone fica totalmente seco.

1B

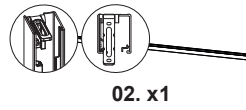
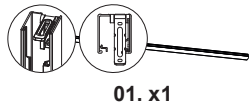
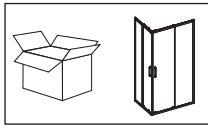

B2



| SIZE (mm) | A(mm) |
|-----------|-------|
| 700×900 | 682 |
| 700×1000 | 982 |
| 700×1200 | 1182 |

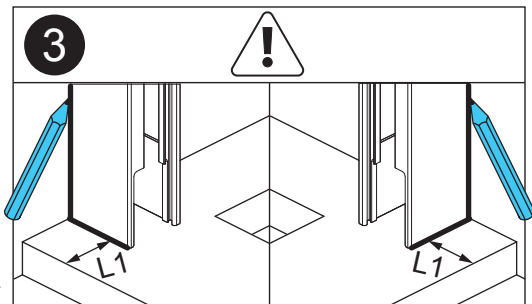
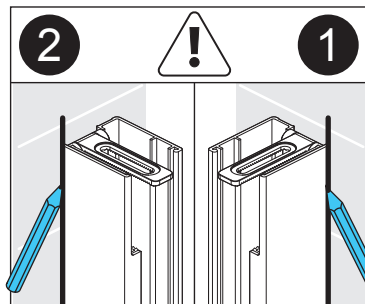
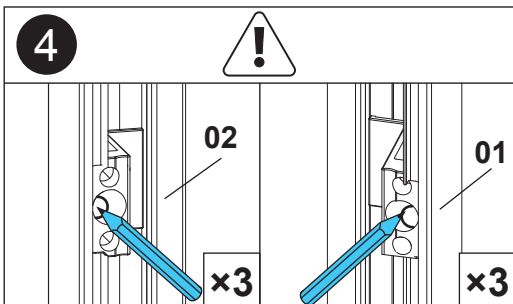
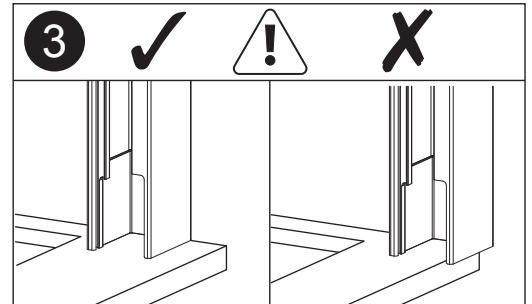
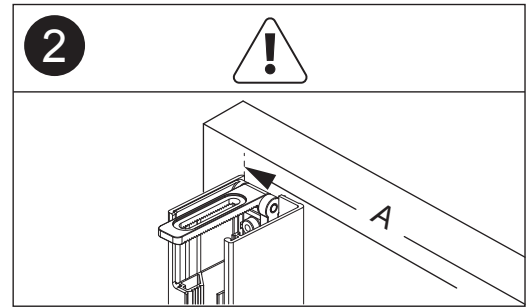
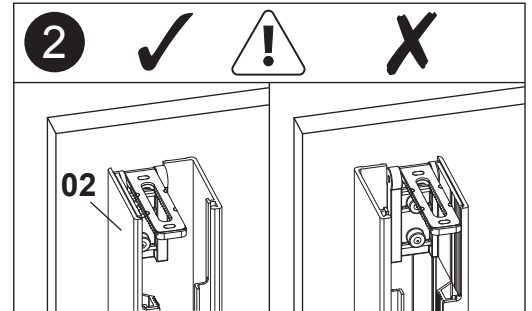
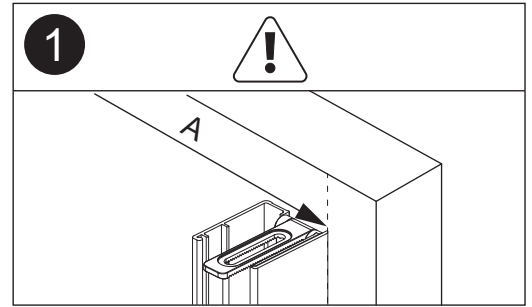
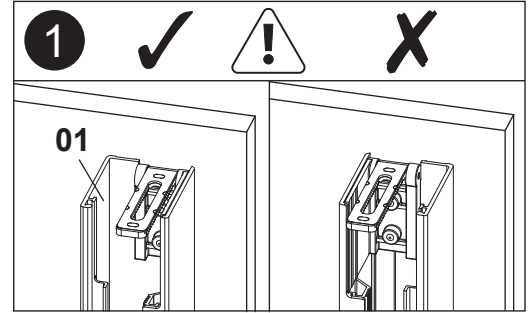
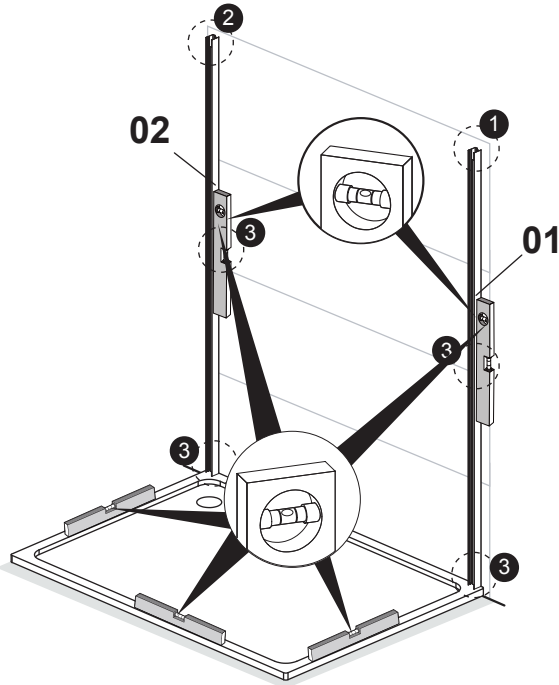
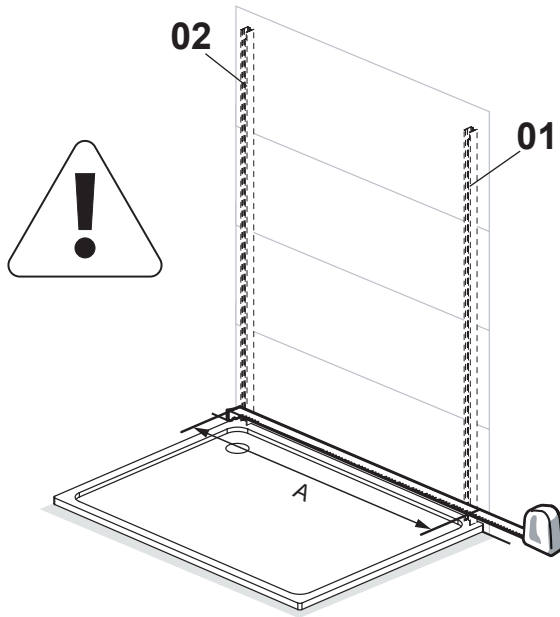

2B

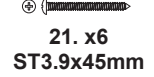
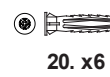
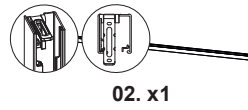
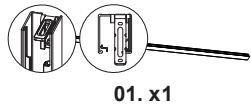
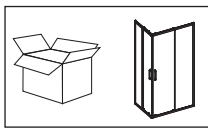

B2

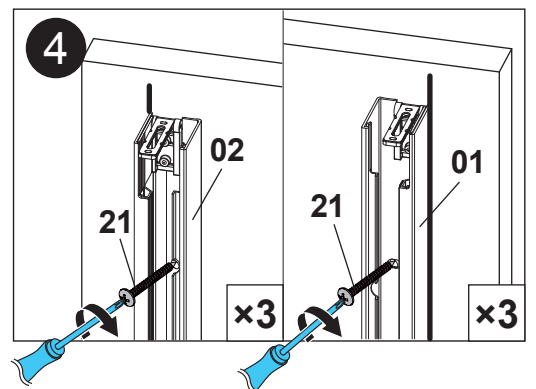
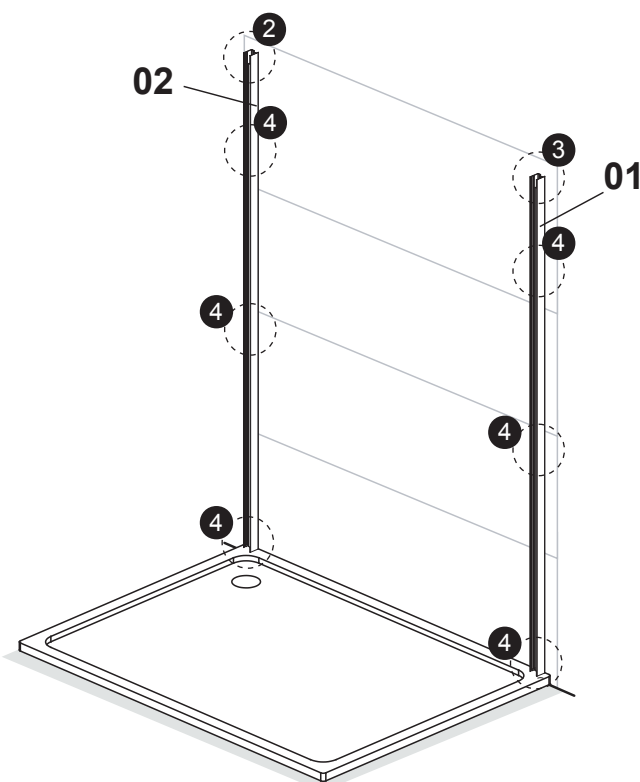
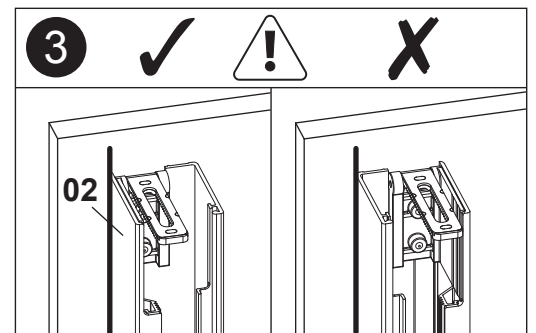
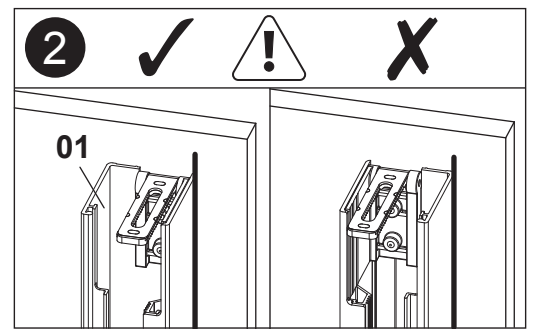
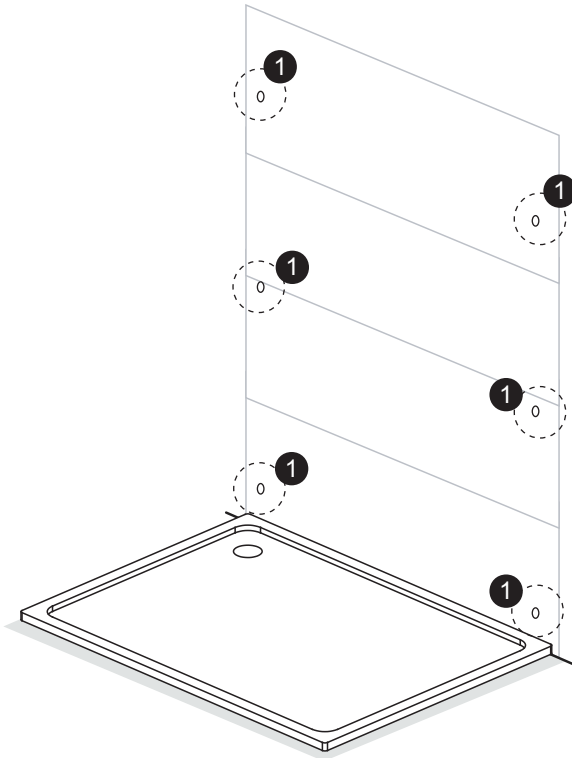
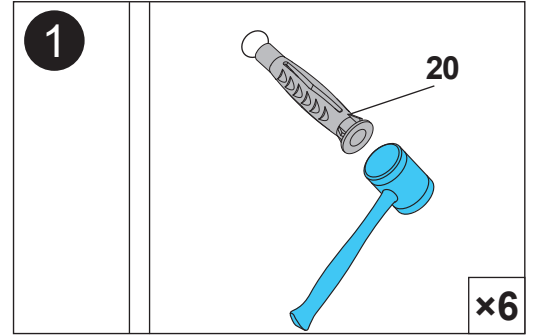
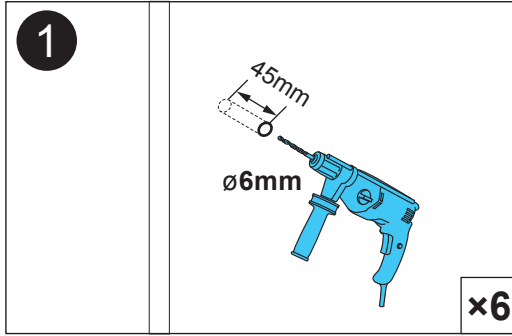

3B

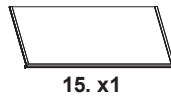
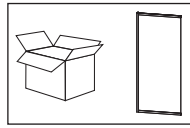
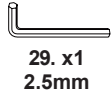
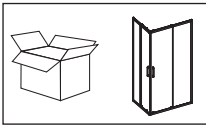

B2

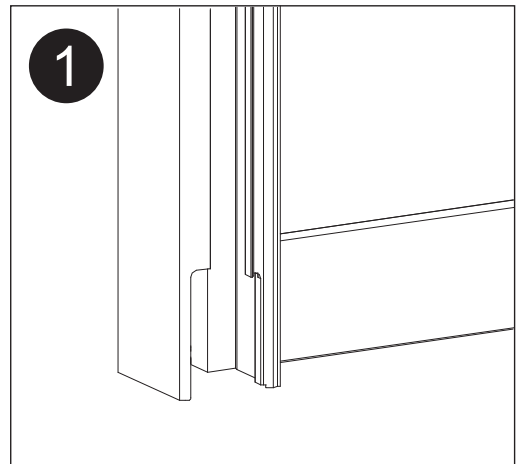
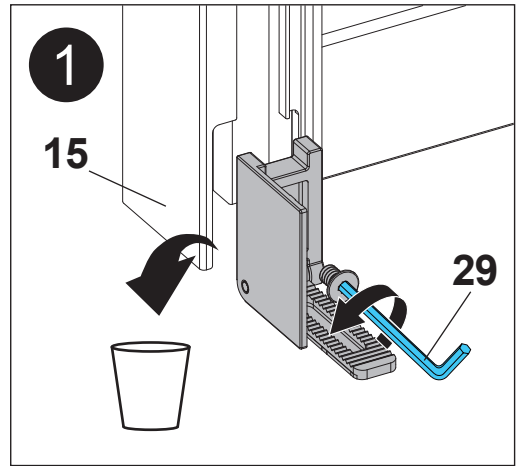
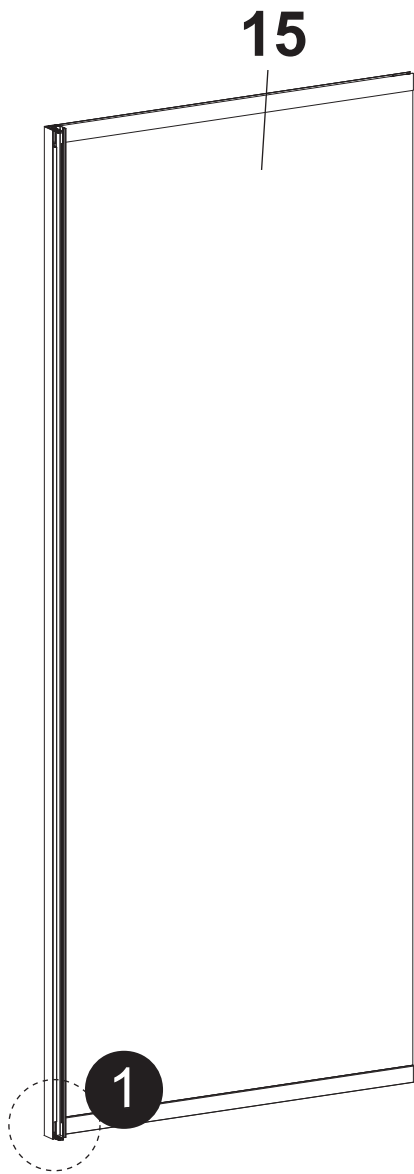

4B

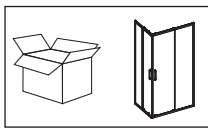

22. x2
M4x10mm

29. x1
2.5mm

30. x1

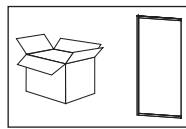

15. x1

08. x1

B2

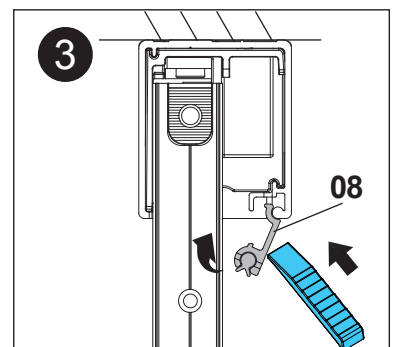
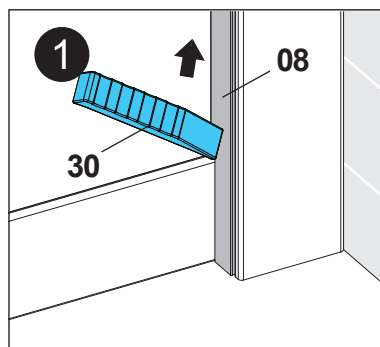
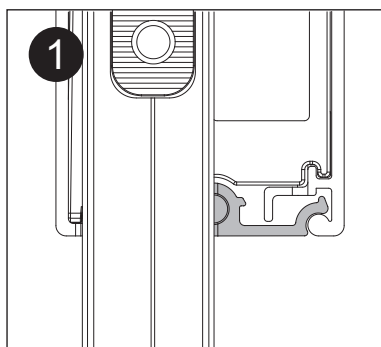
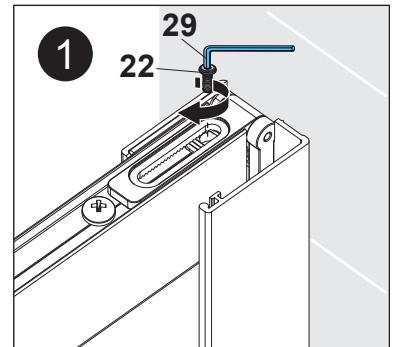
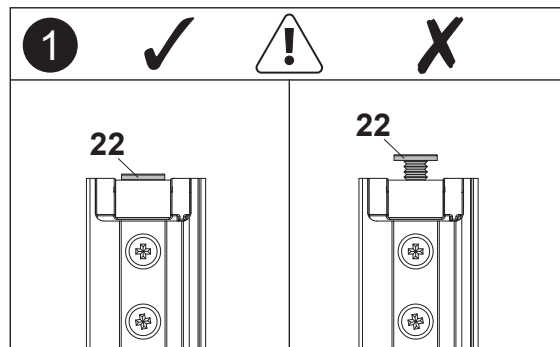
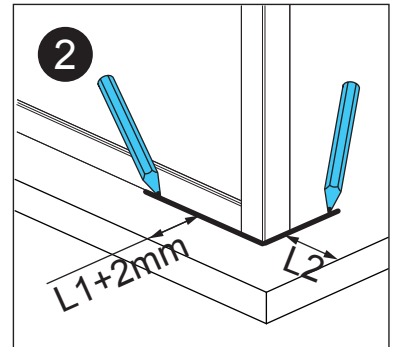
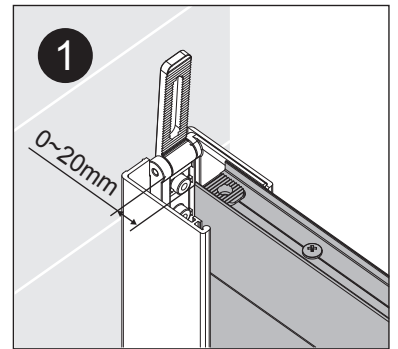
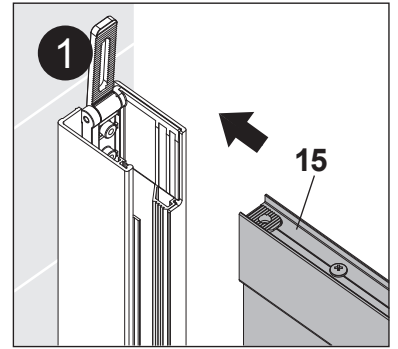
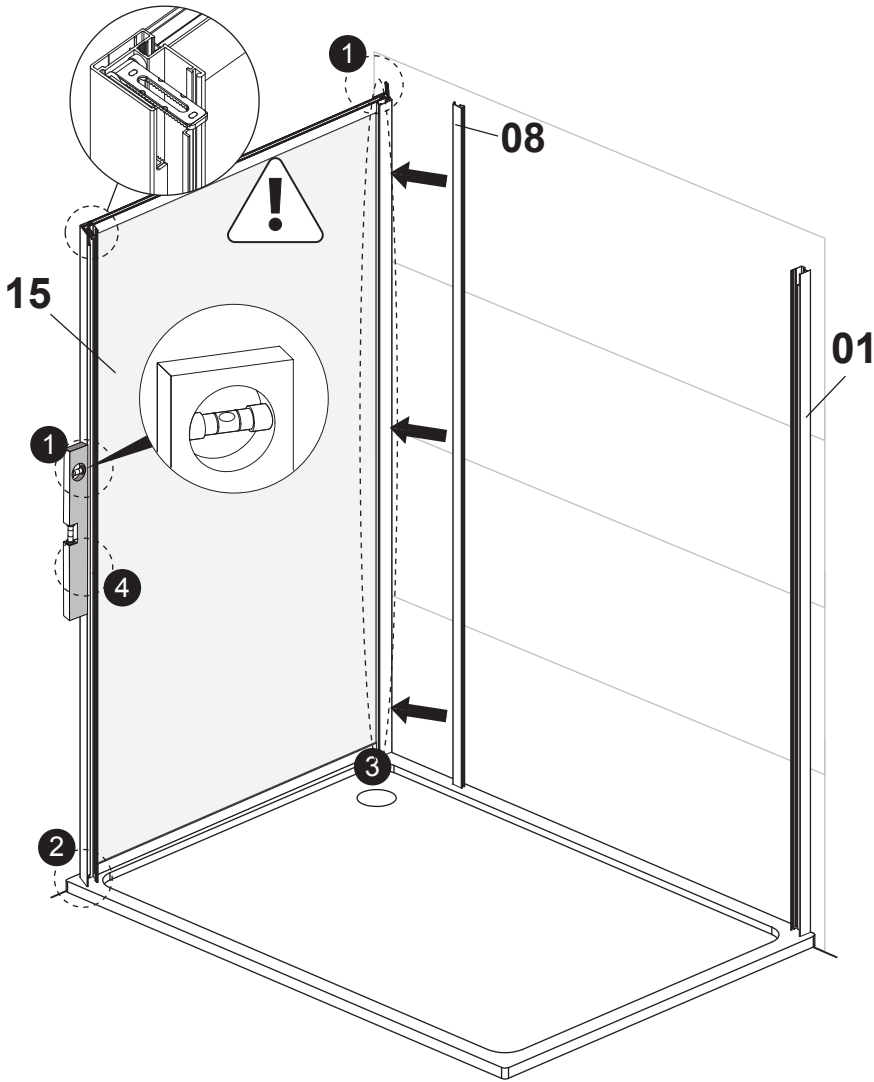

5B

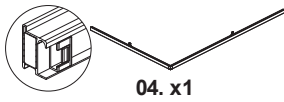
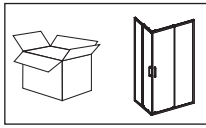

04. x1

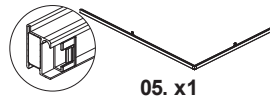

05. x1

B2

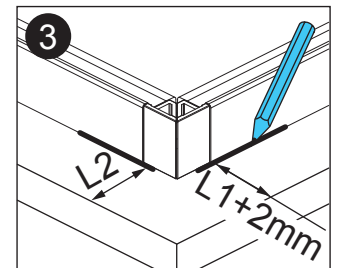
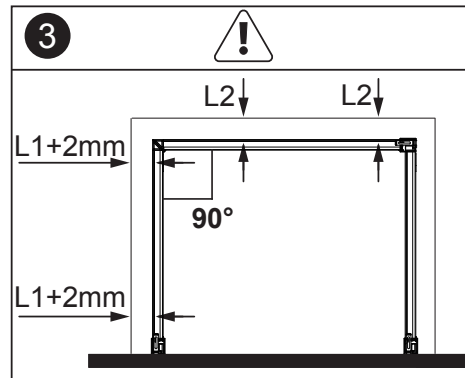
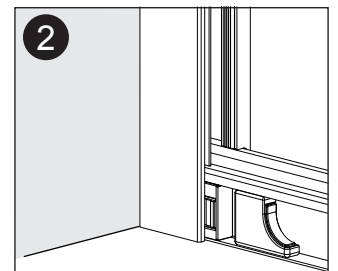
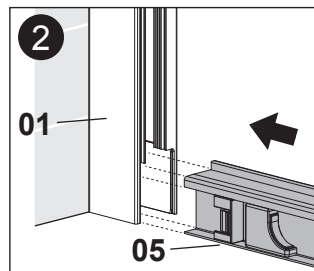
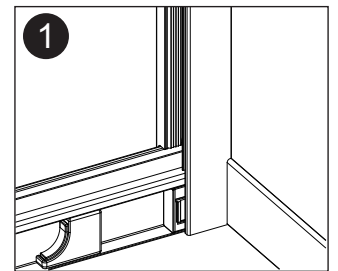
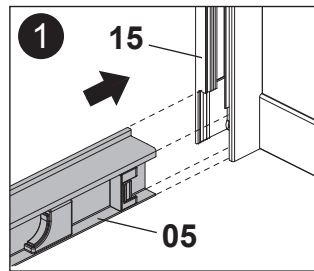
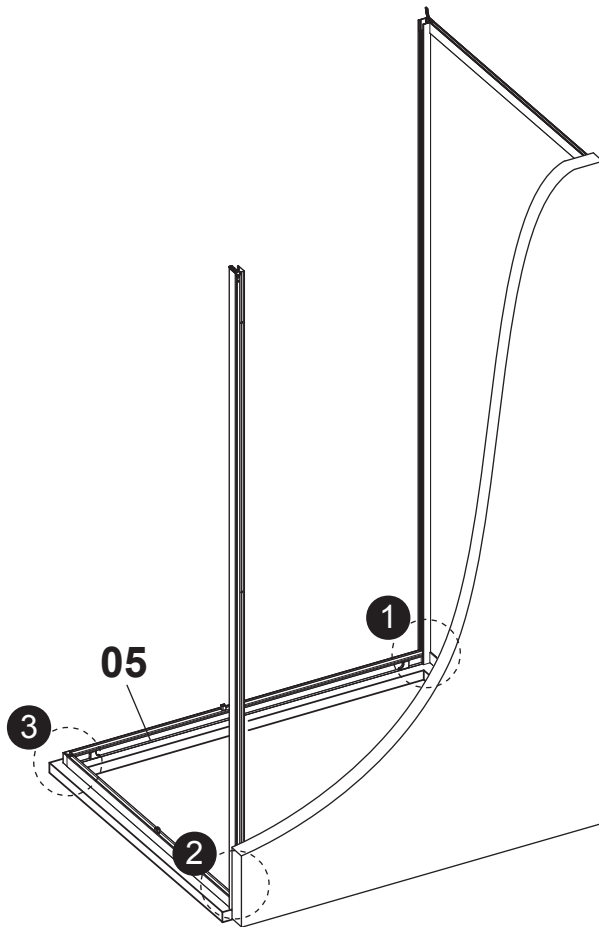
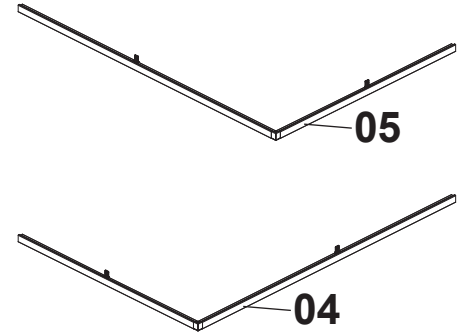
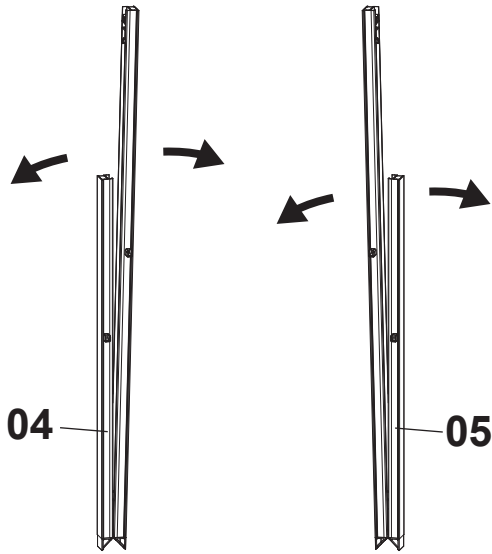

6B

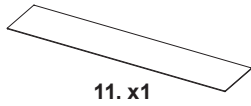
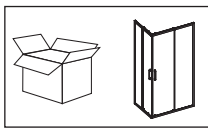

11. x1

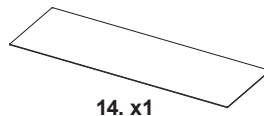

14. x1



50-1. x2



50-2. x2

B2

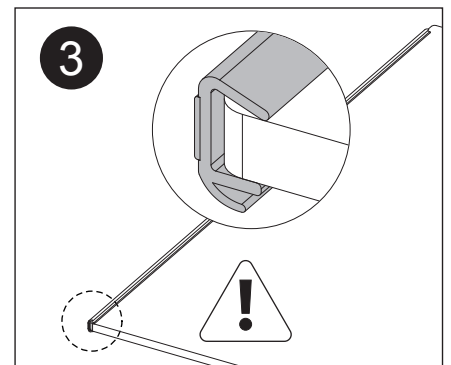
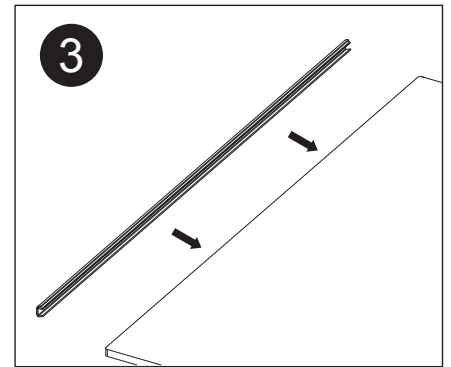
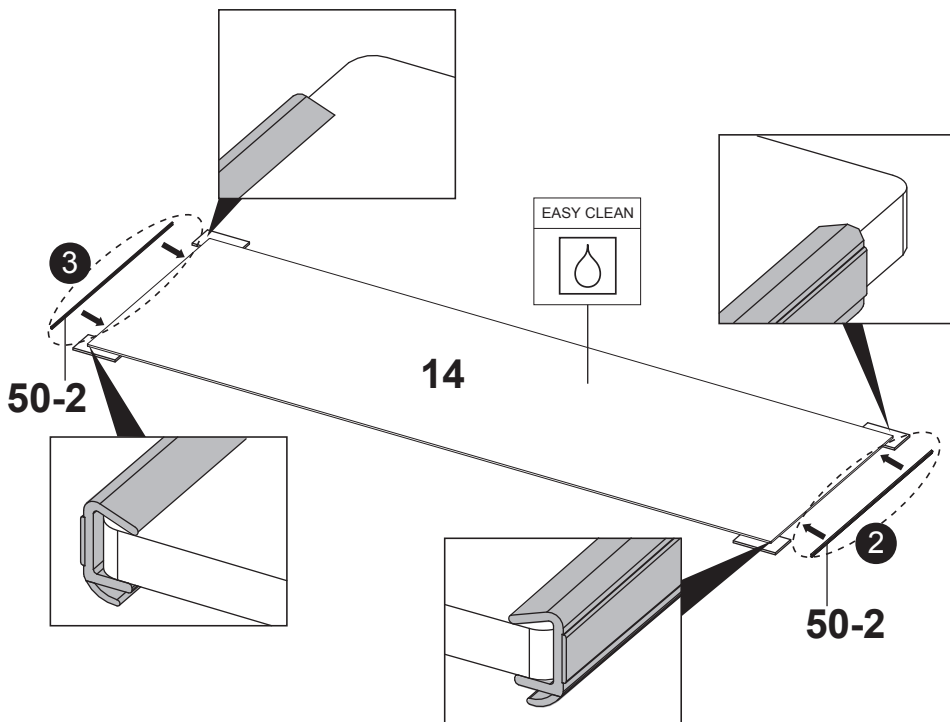
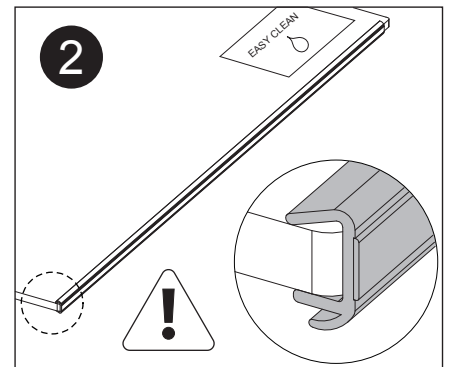
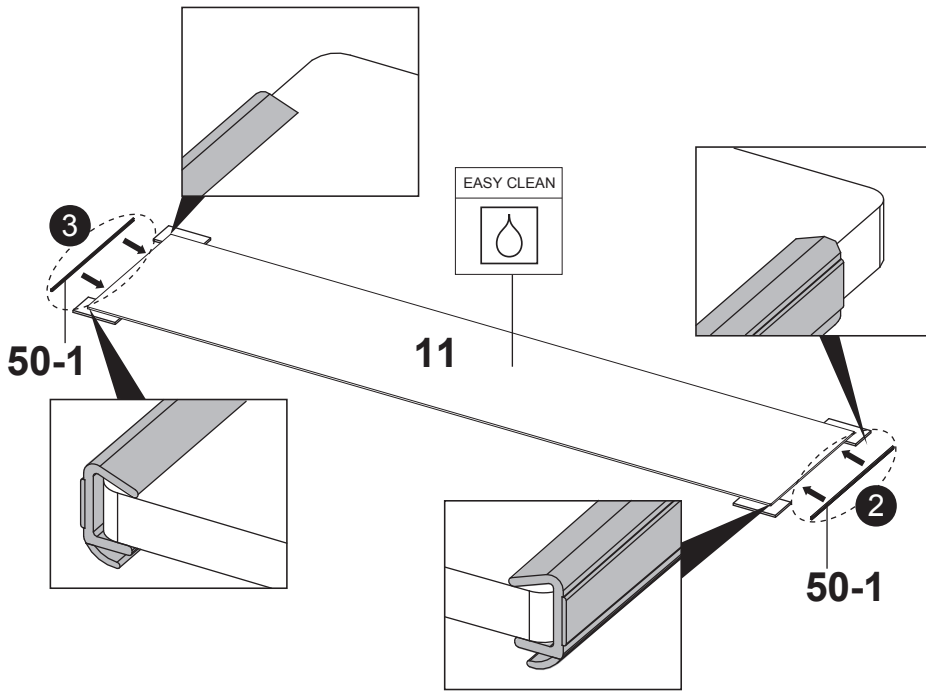
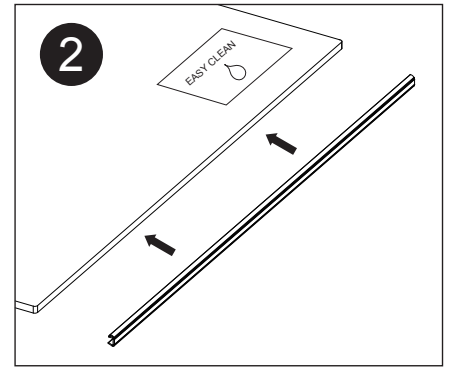
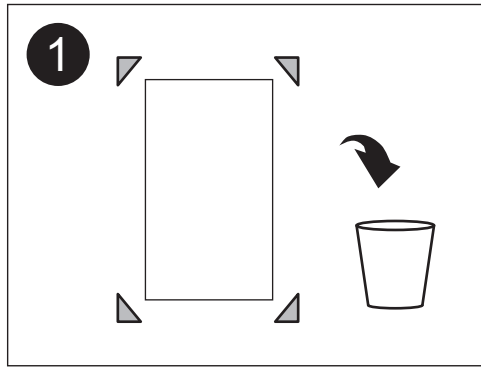

7B

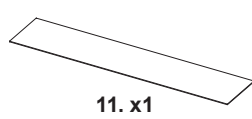
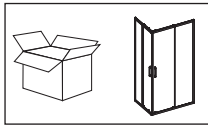

11. x1

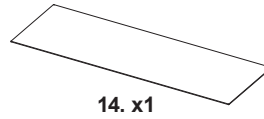

14. x1

B2

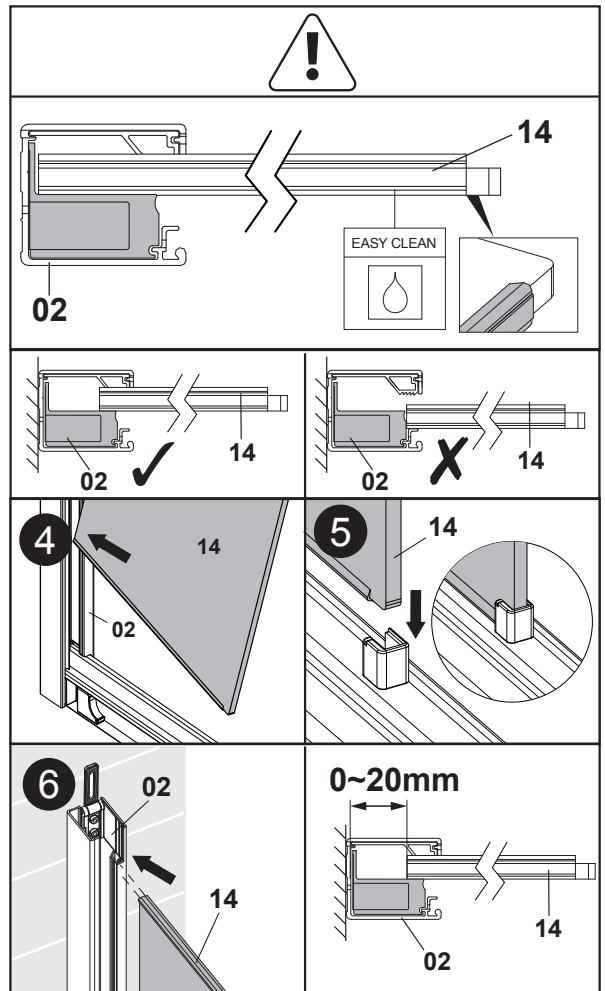
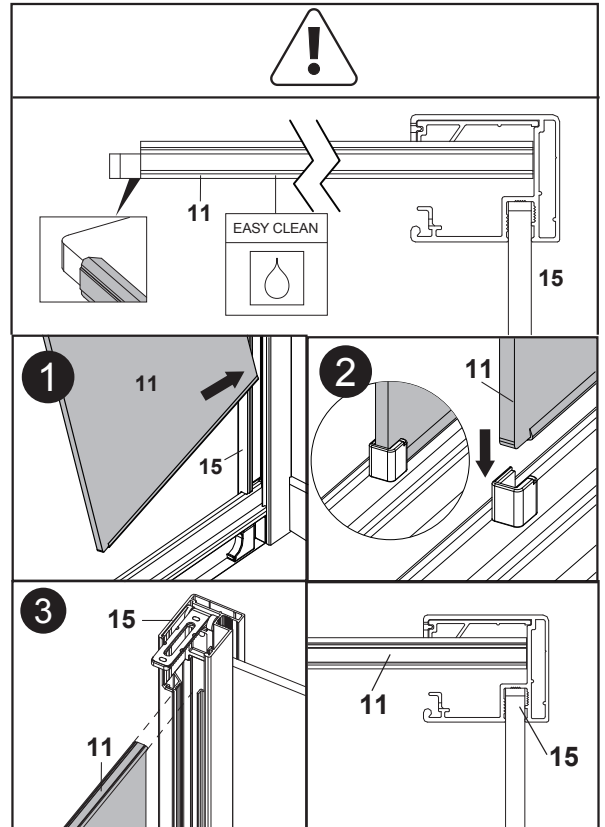
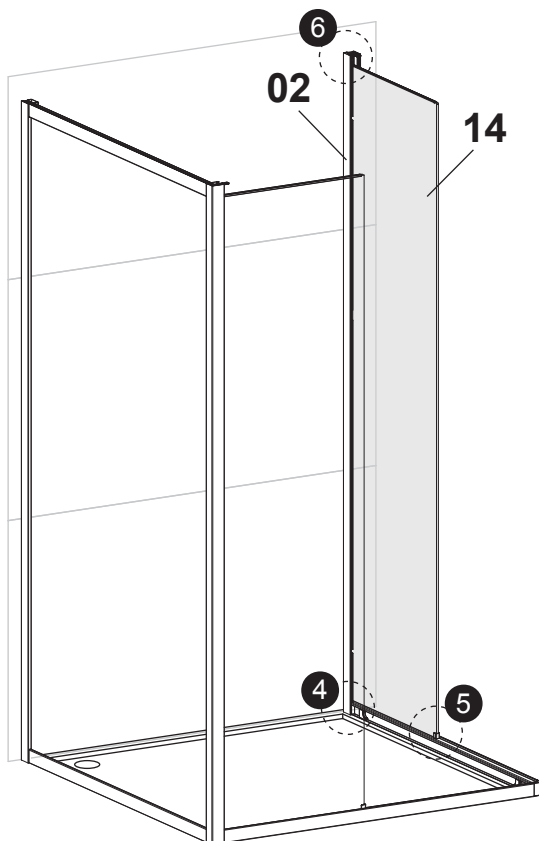
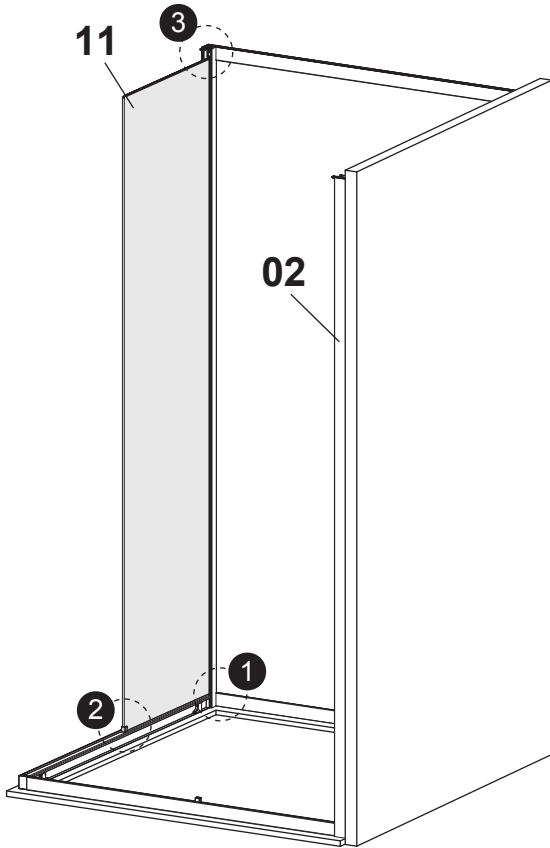

8B

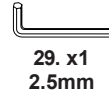
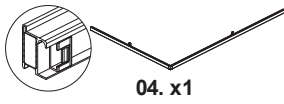
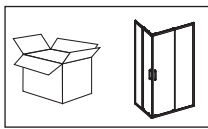

B2

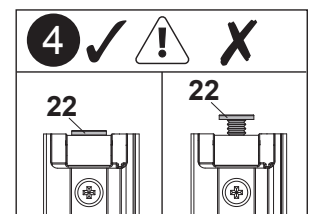
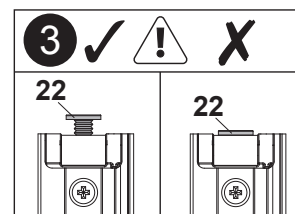
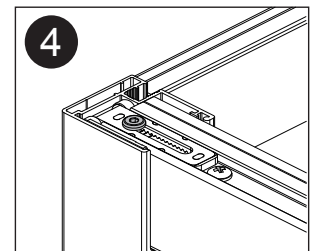
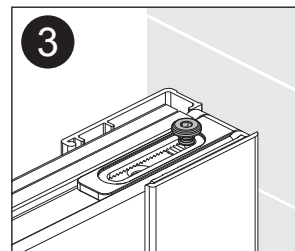
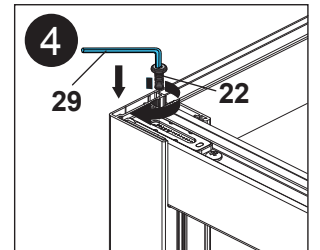
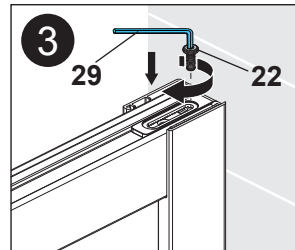
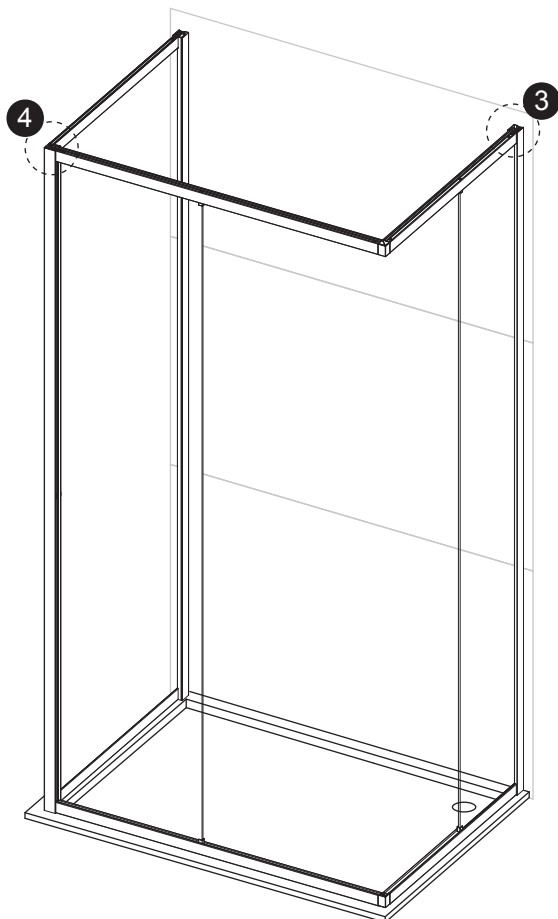
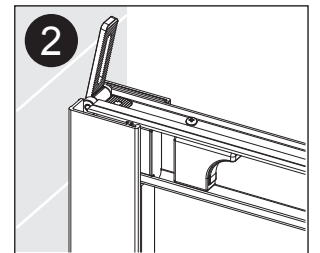
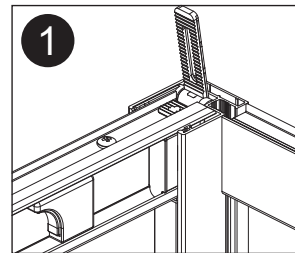
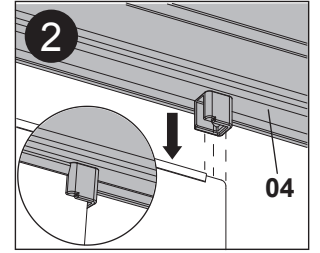
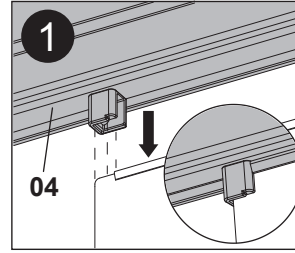
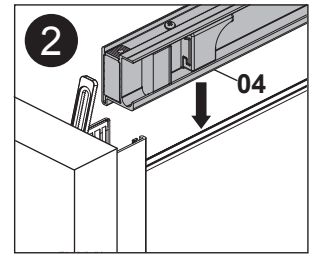
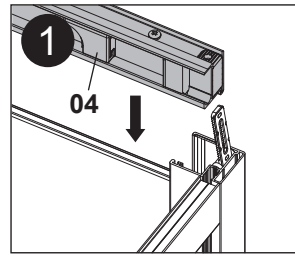
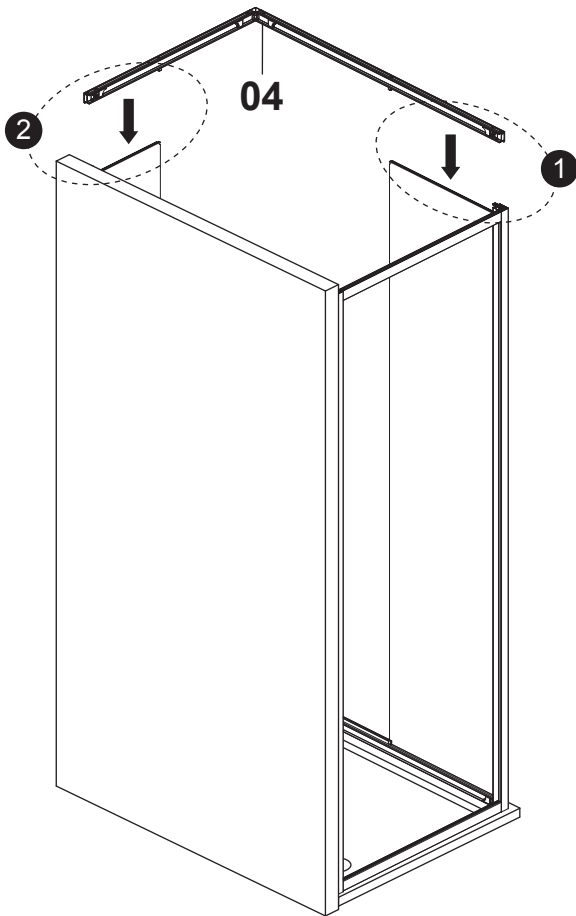

9B

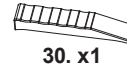
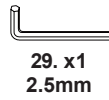
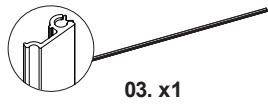
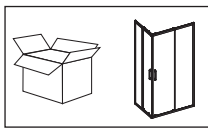

B2

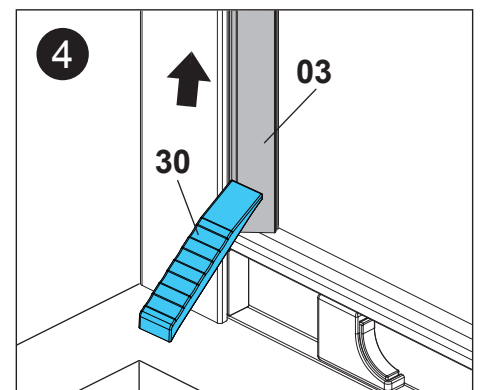
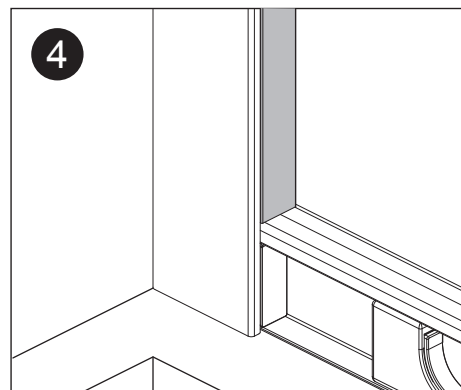
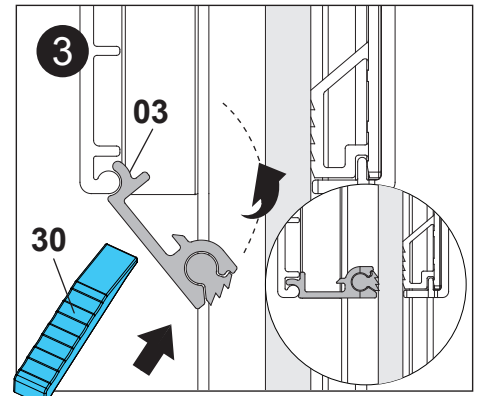
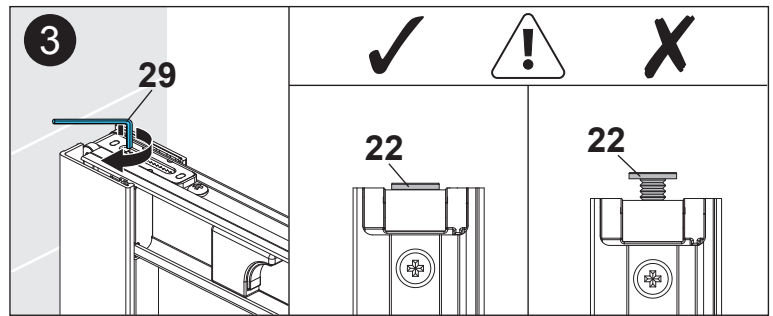
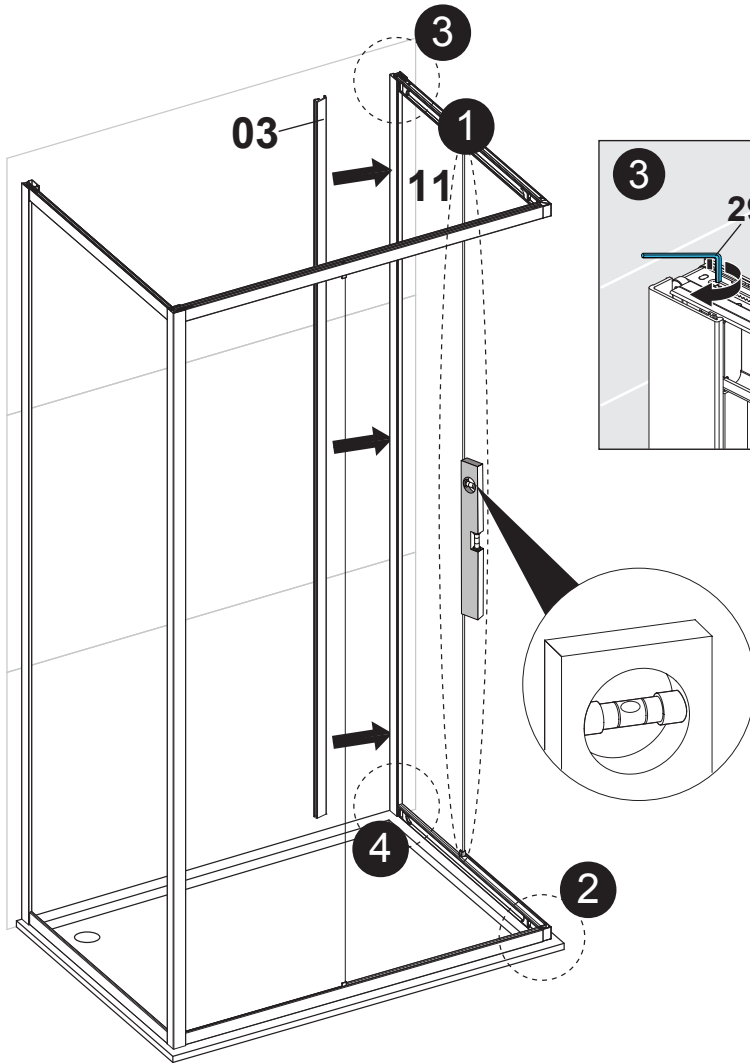
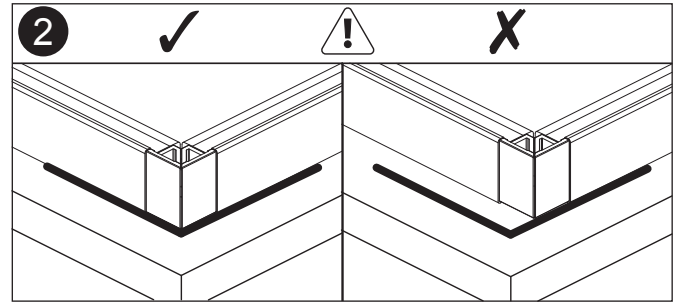
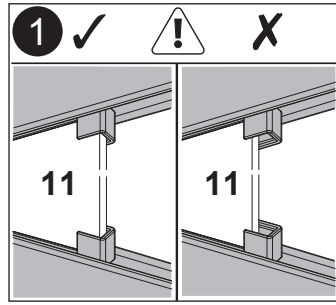

10B

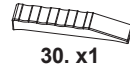
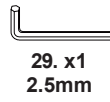
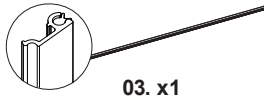
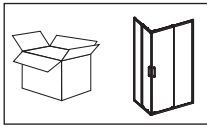

B2

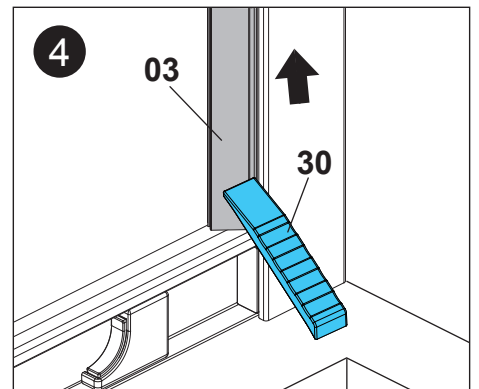
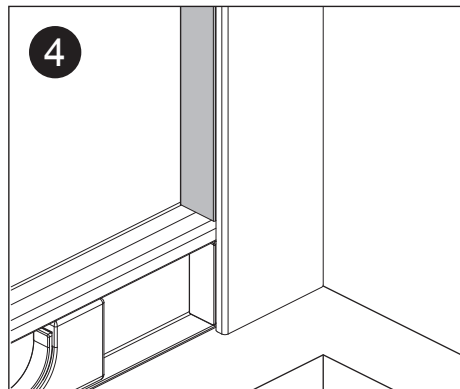
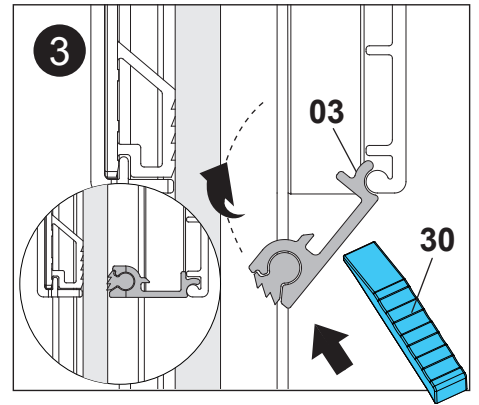
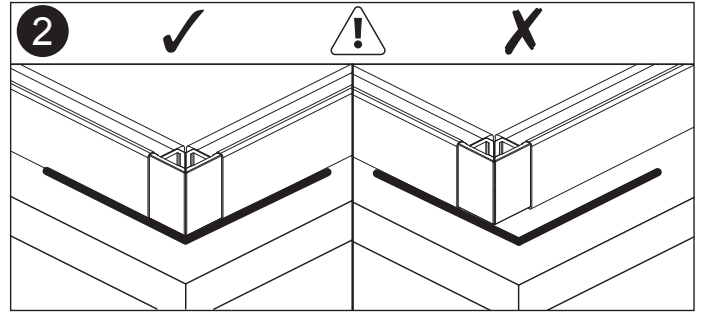
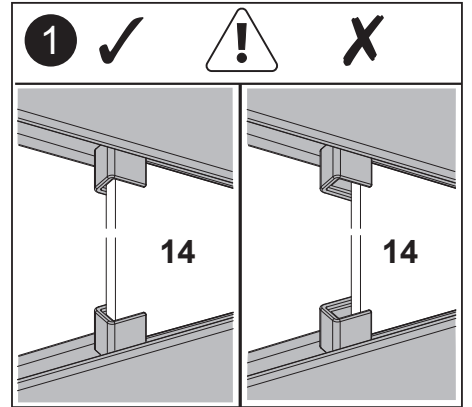
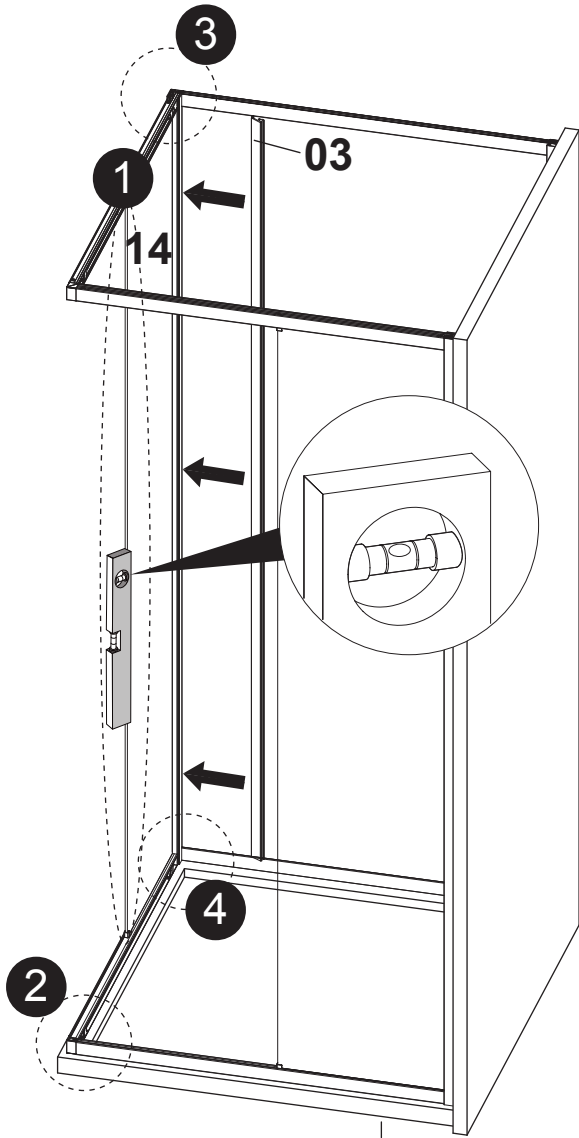

11B

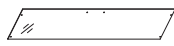
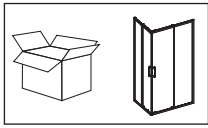

12. x1

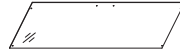

13. x1



26. x4



27. x4



29. x1
2.5mm

B2

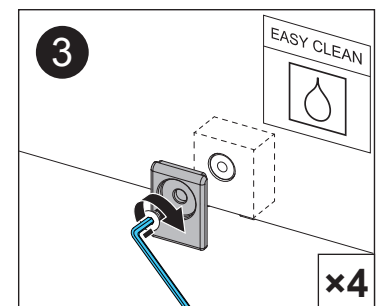
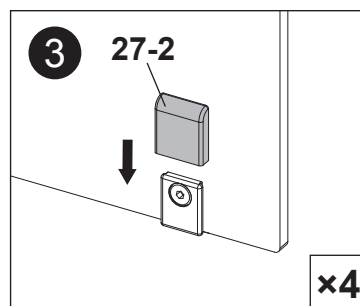
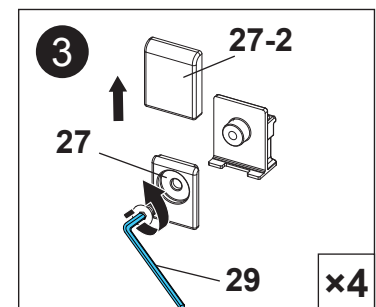
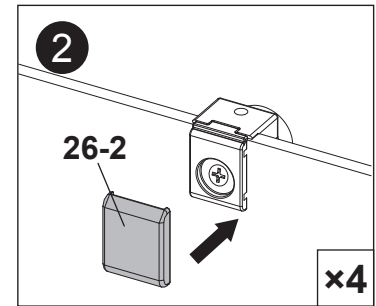
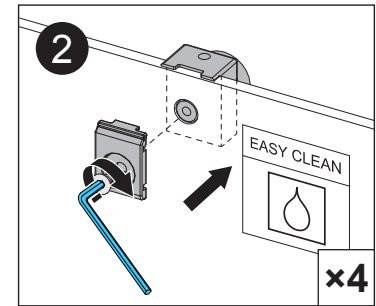
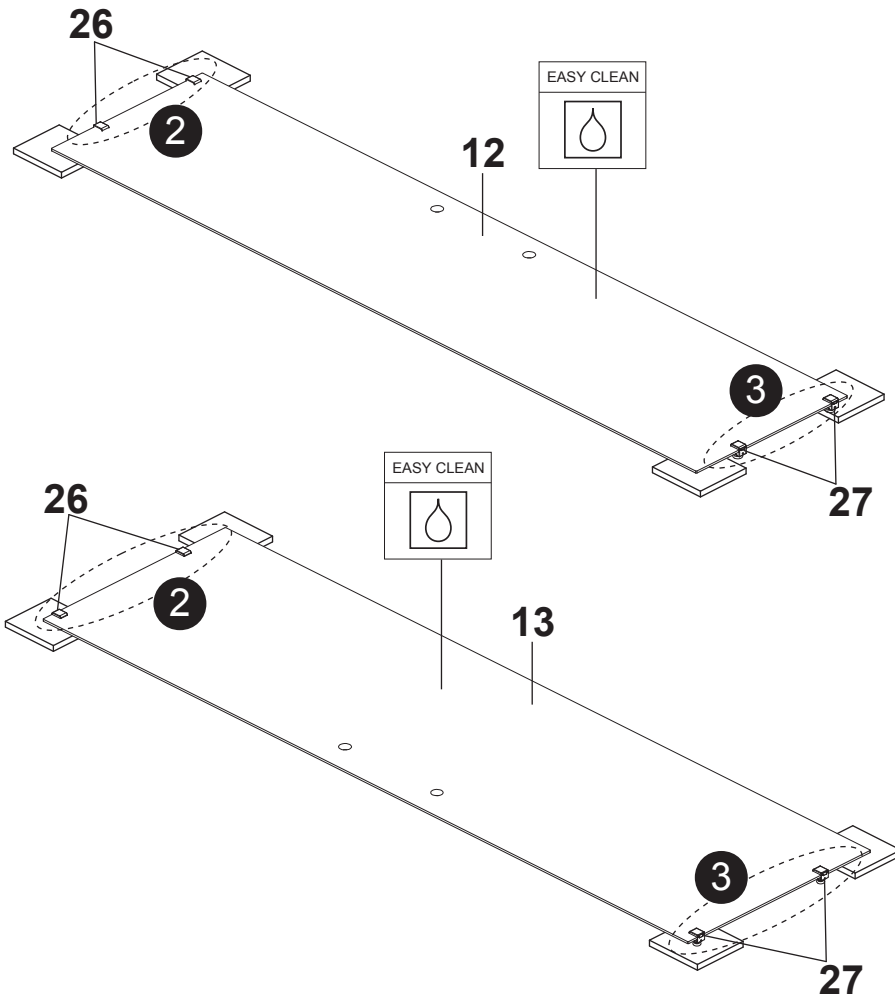
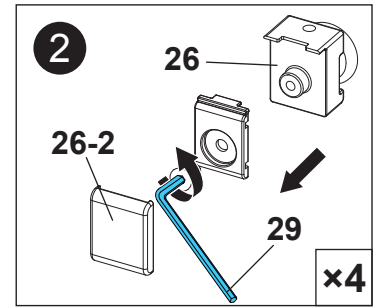
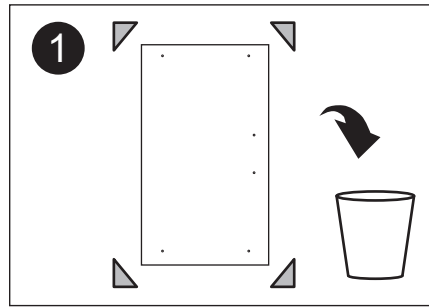

12B

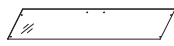
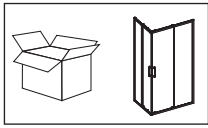

12. x1

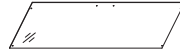

13. x1

B2

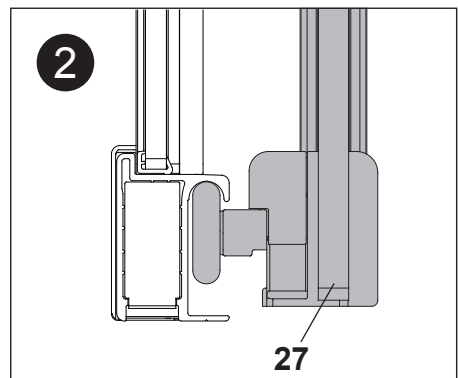
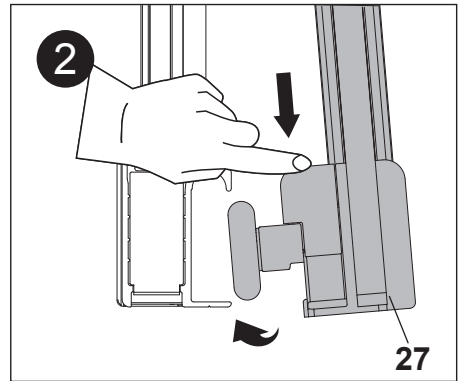
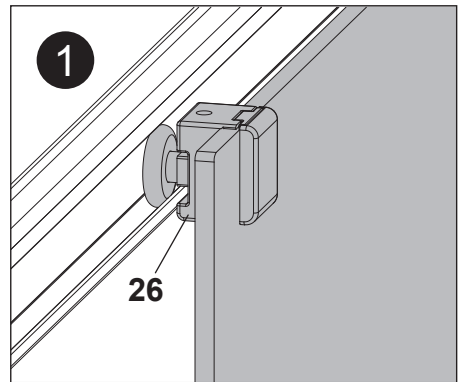
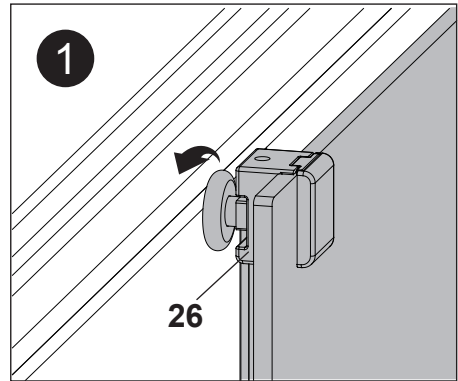
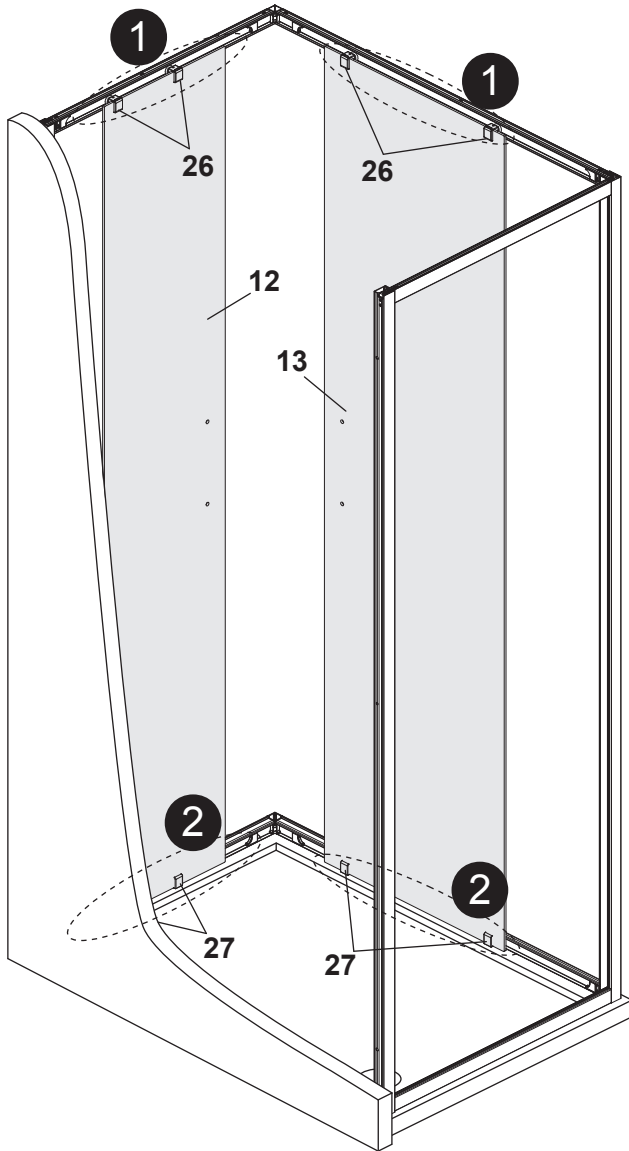
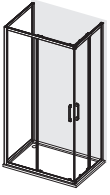

13B

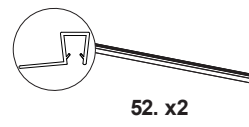
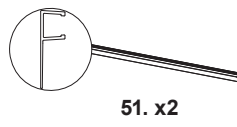
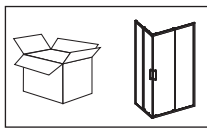

51. x2

52. x2

B2

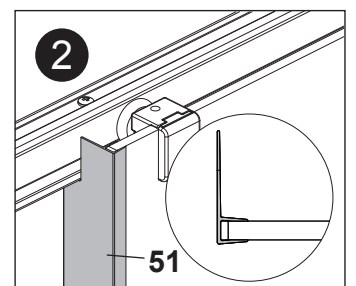
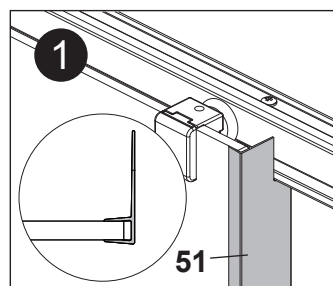
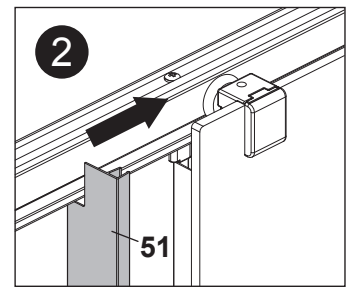
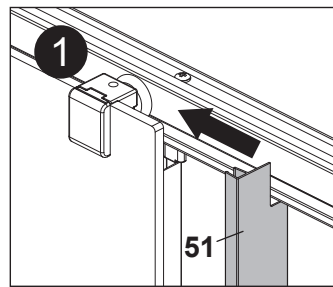
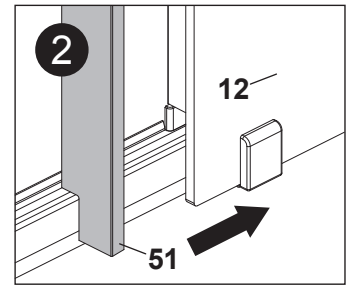
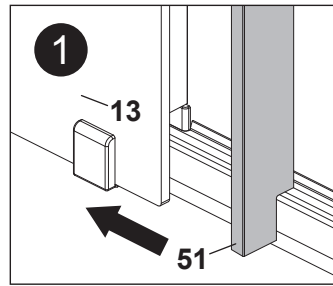
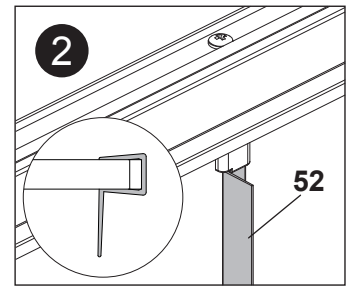
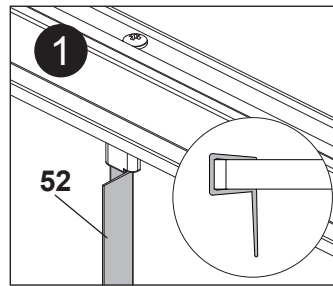
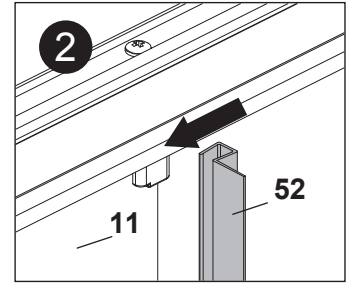
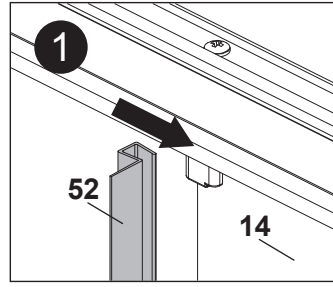
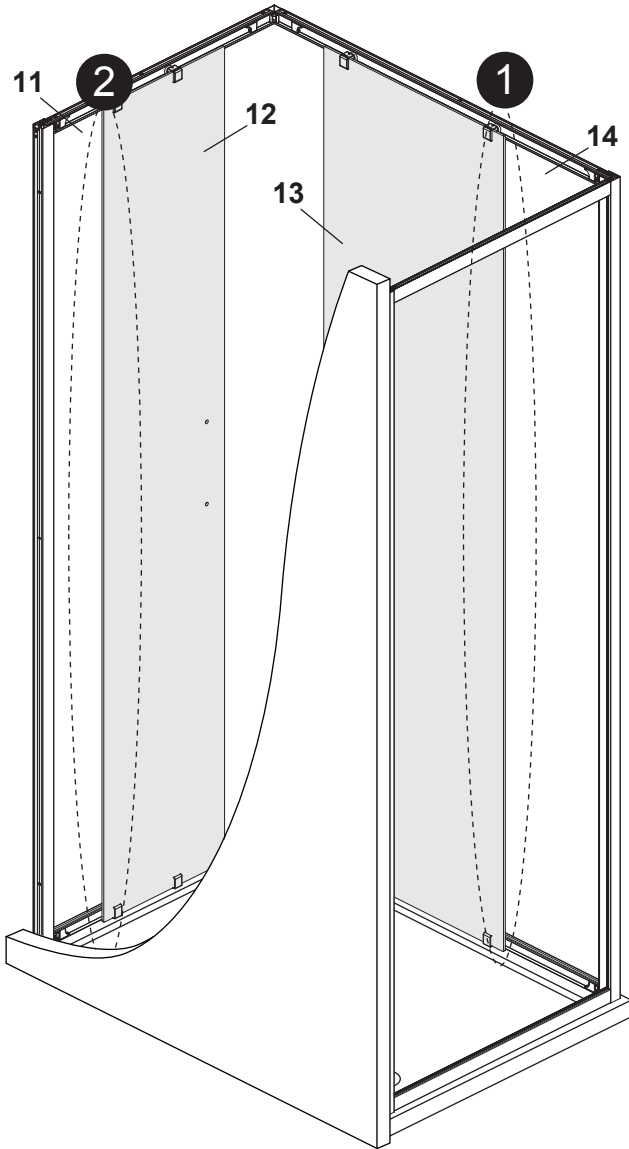

14B

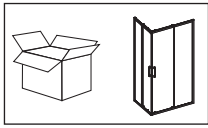

53. x2



29. x1
2.5mm



30. x1

B2

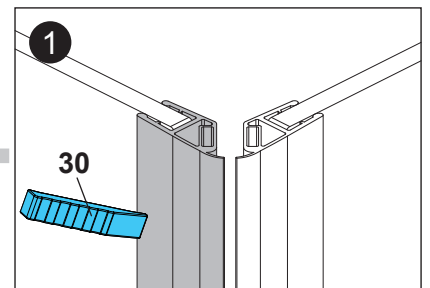
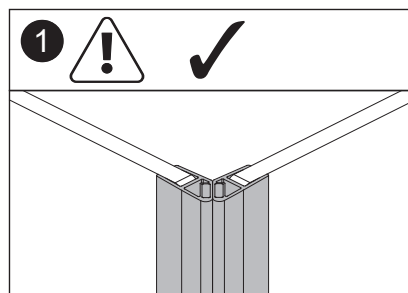
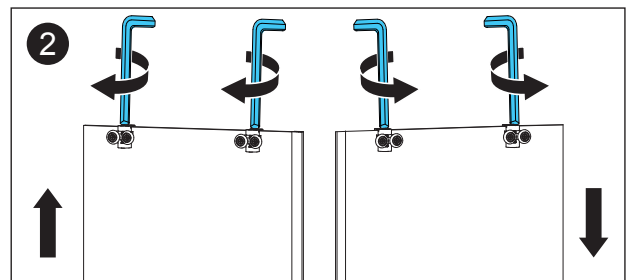
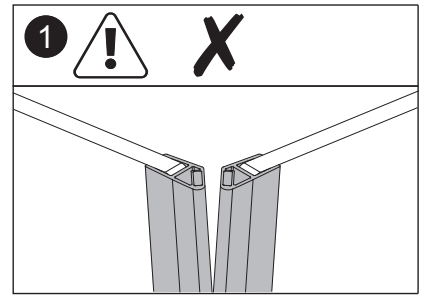
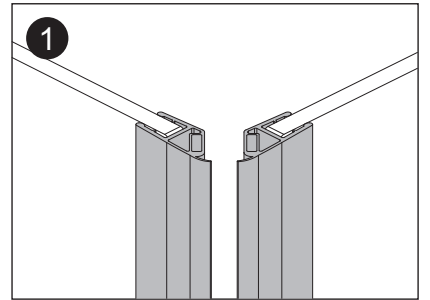
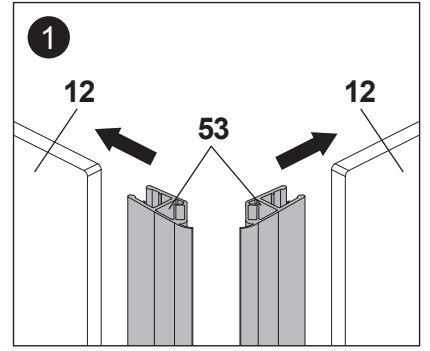
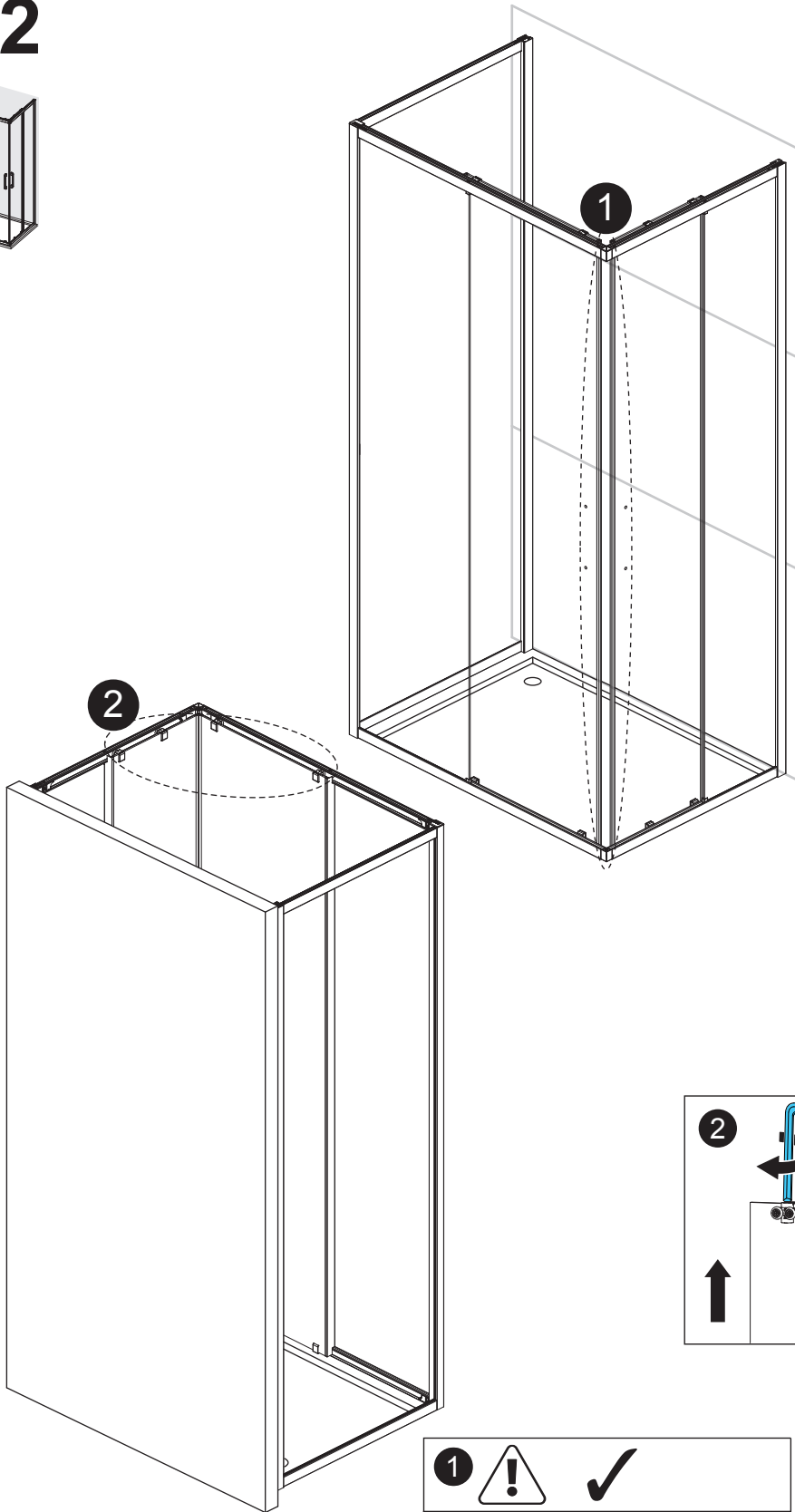

15B

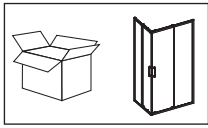

28. x2

B2

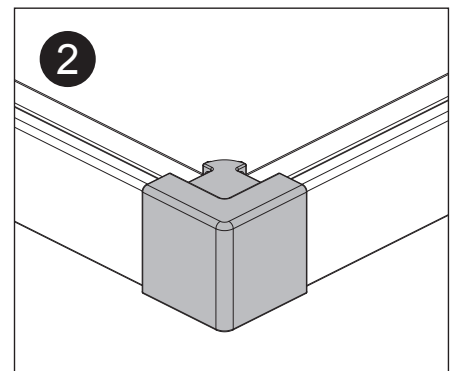
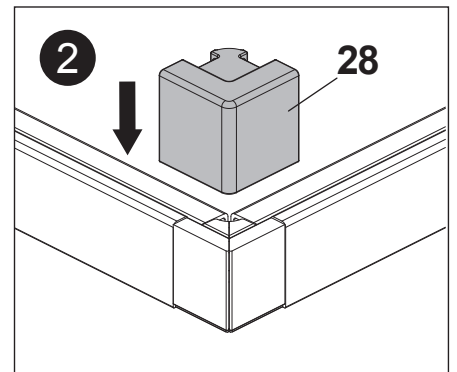
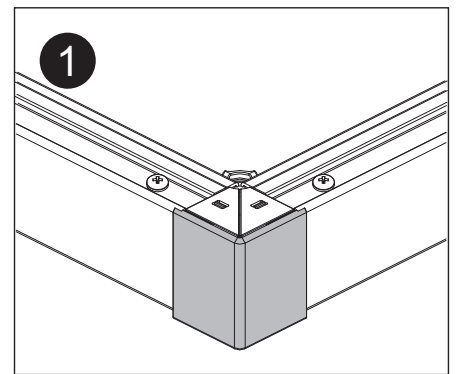
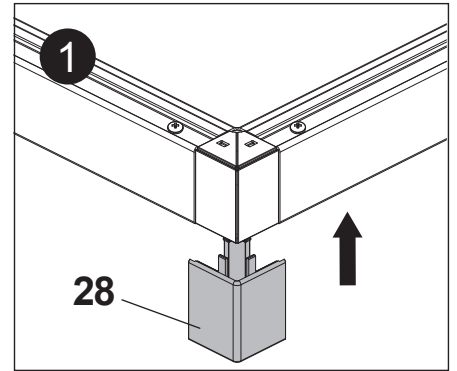
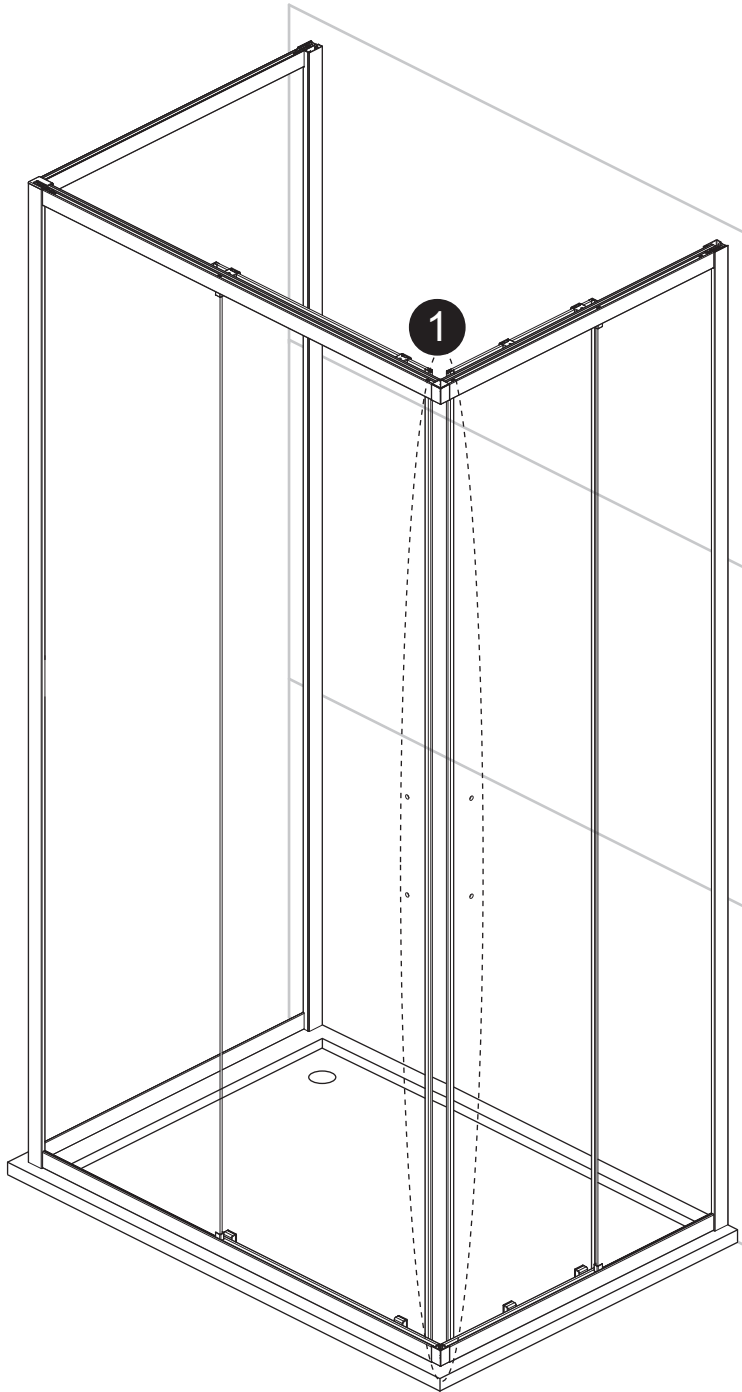
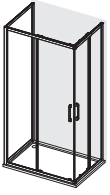

16B

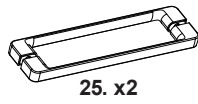
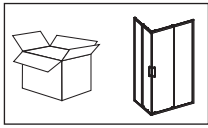

B2

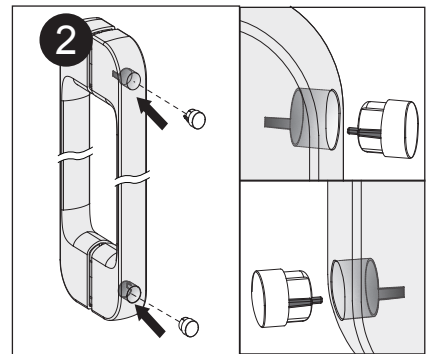
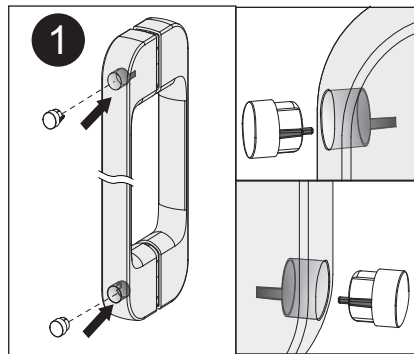
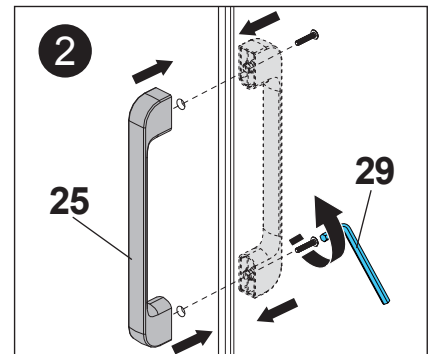
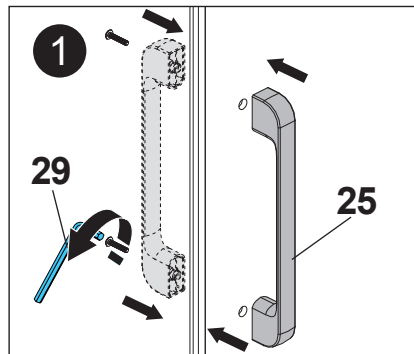
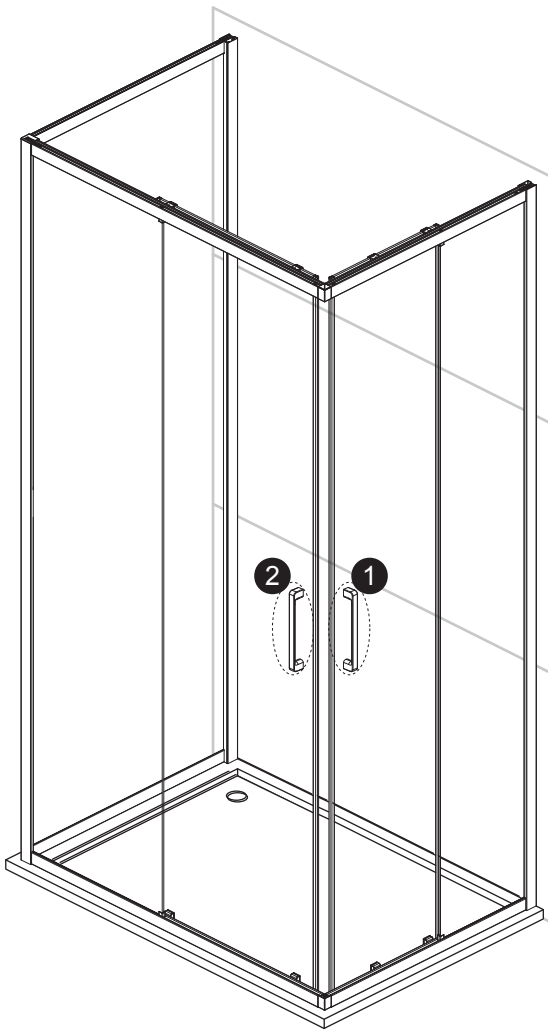
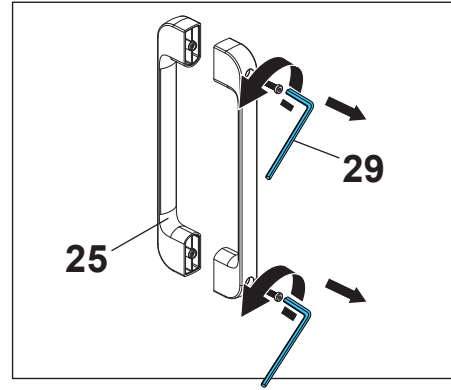

17B

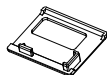
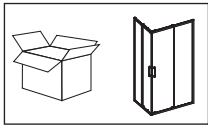

23. x1

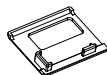

24. x1

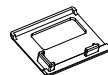
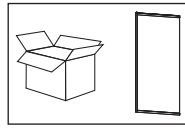

24. x1

B2

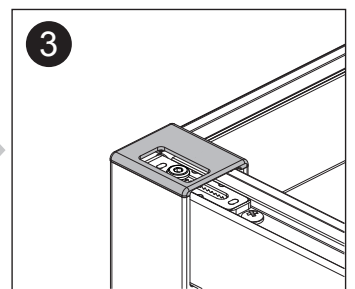
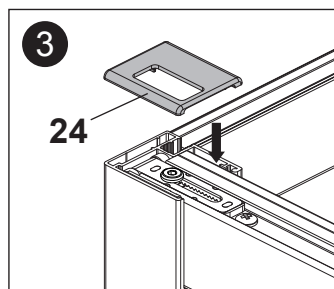
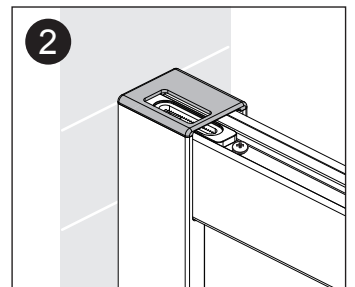
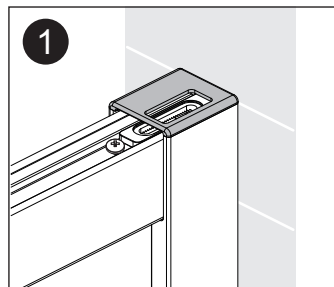
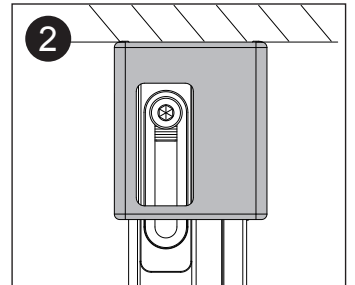
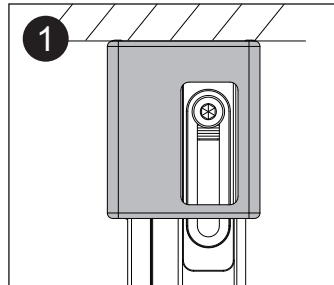
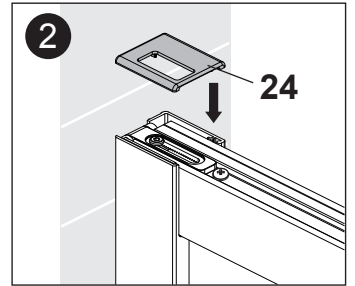
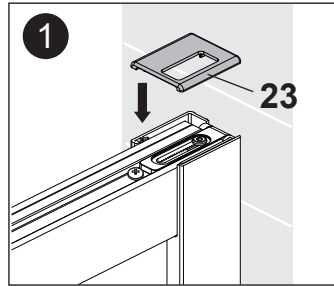
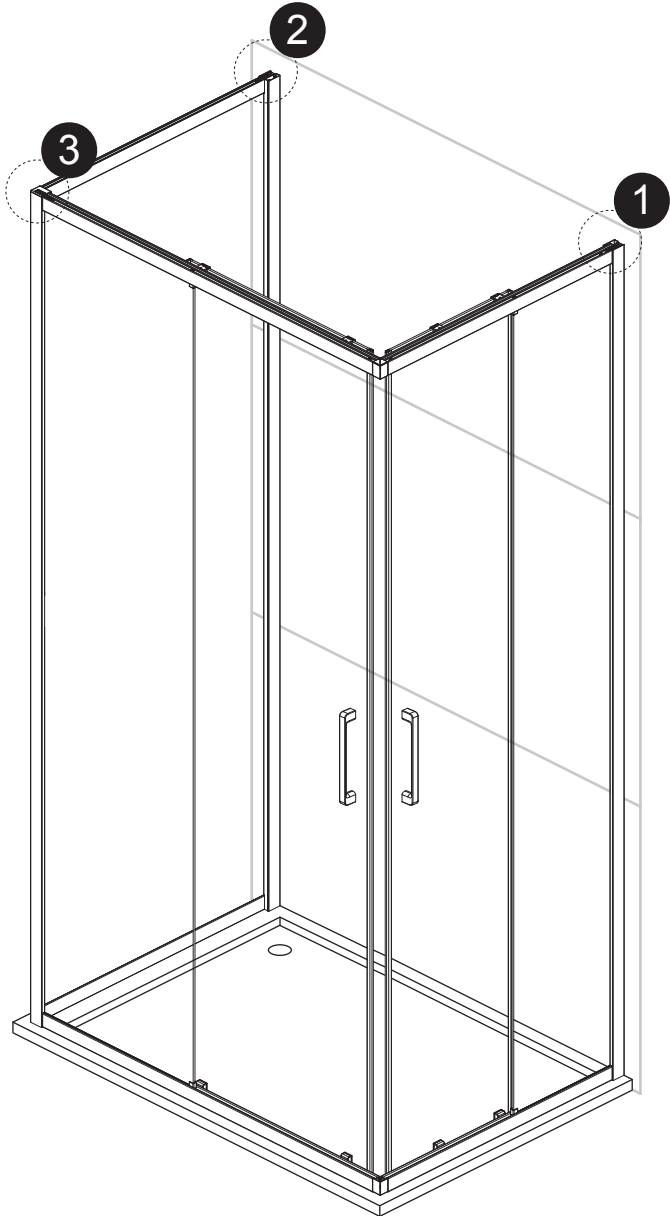

18B

B2

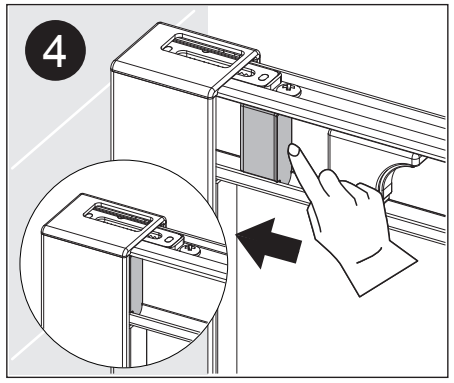
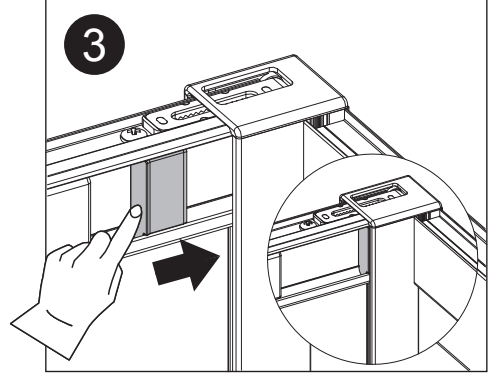
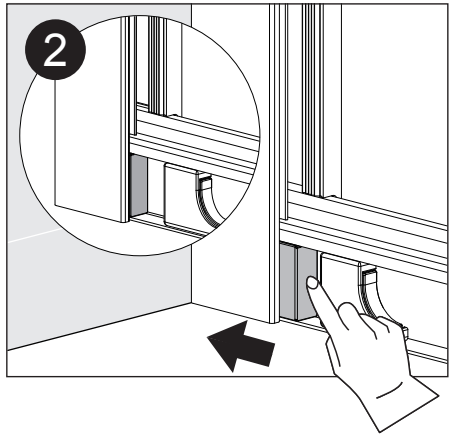
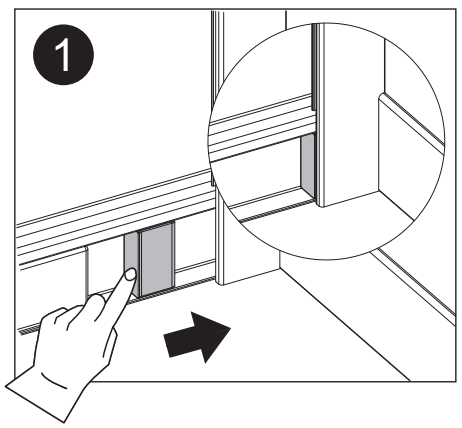
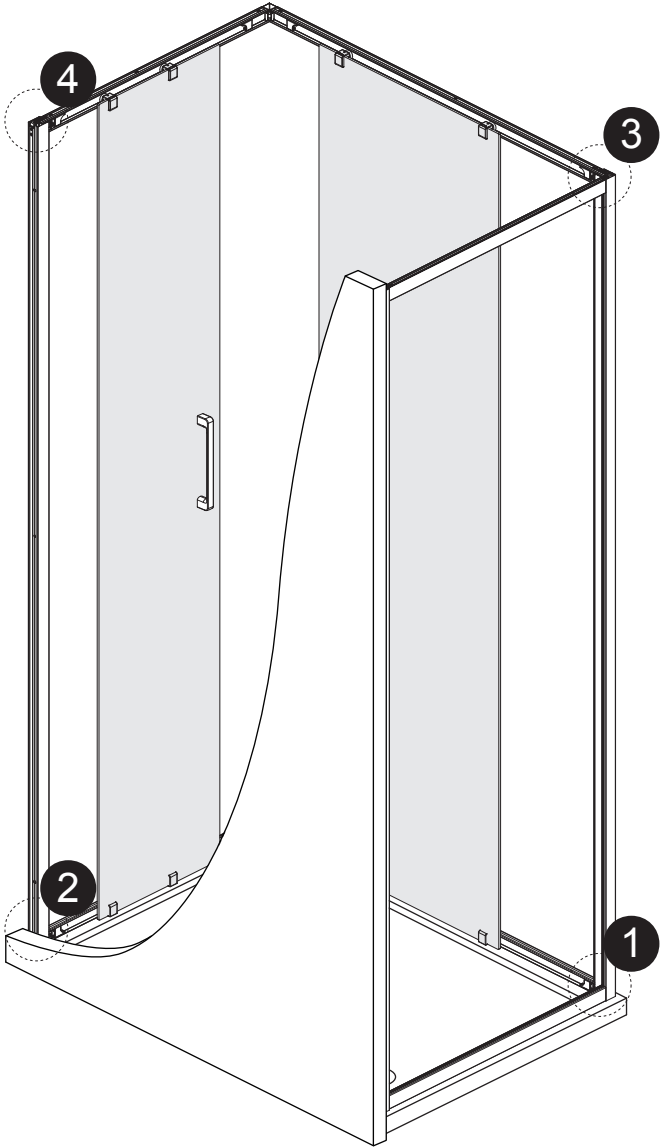
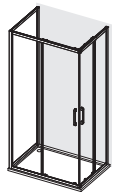

19B

B2

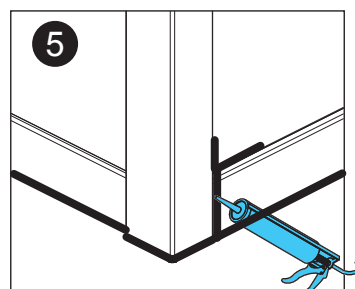
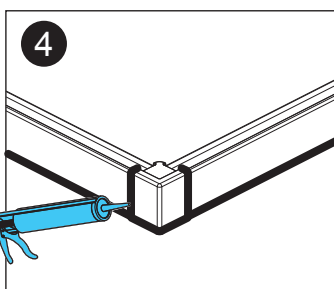
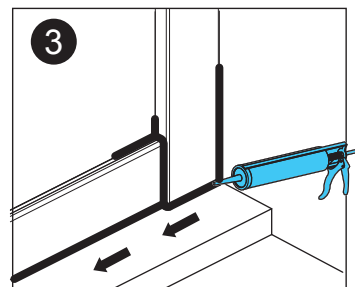
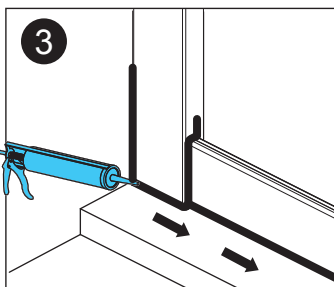
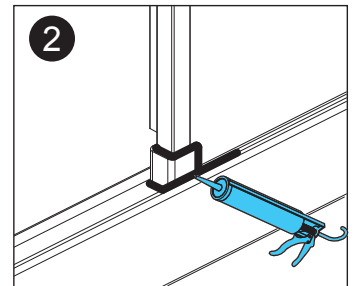
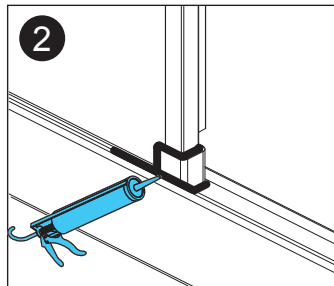
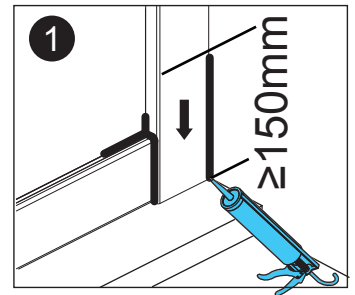
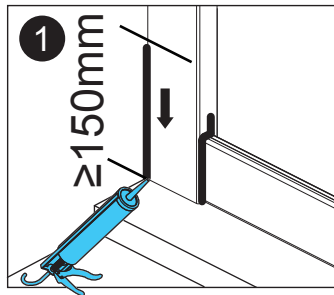
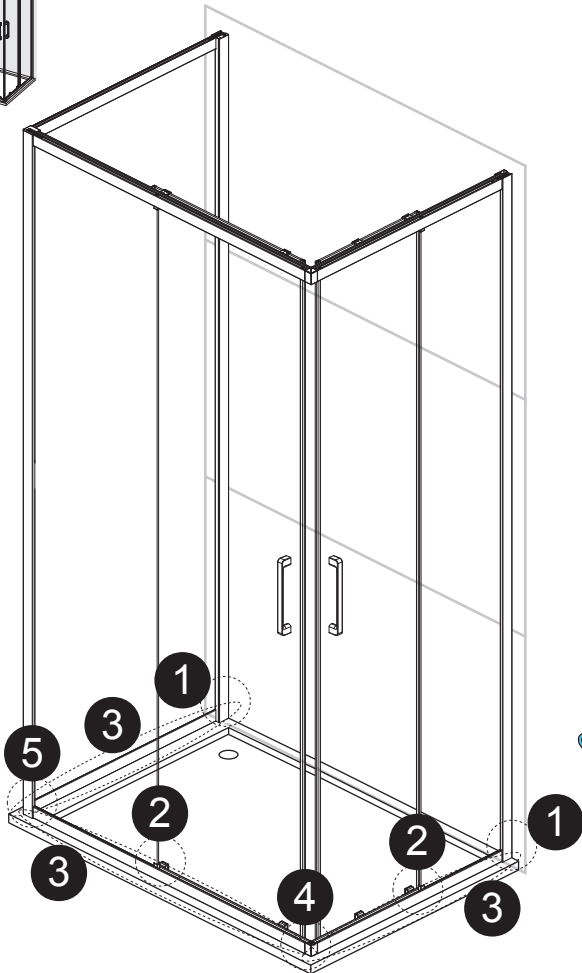
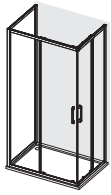

- EN** Do not use the shower enclosure for at least 24 hours in order to allow the silicone sealant to cure fully.
- FR** N'utilisez pas votre douche pendant au moins 24 heures afin de permettre aux joints de silicone de sécher entièrement.
- PL** Po zakończonym montażu, nie używaj brodzika prysznicowego przez co najmniej 24 godziny, aby umożliwić pełne osadzenie się uszczelnacza silikonowego.
- RO** Nu utilizați cab.ina de duș timp de cel puțin 24 pentru a permite izolației de silicon să se usuc complet.
- ES** No use la cabina de la ducha por lo menos 24 para dejar que el sellador de silicón fragüe completamente.
- PT** Não utilize a divisória de chuveiro durante, no mínimo, 24 horas para garantir que o vedante silicone fica totalmente seco.

EN Care & maintenance **FR Entretien et maintenance**
PL Czyszczenie i konserwacja **RO Îngrijire și întreținere**
ES Cuidados y mantenimiento **PT Cuidados e manutenção**

EN

NOTE: Use warm soapy water and a soft damp cloth to keep the glass clean. Wipe dry with a clean cloth. Scourers, abrasives and chemical cleaners can damage the glass and pattern, and should not be used. In hard water areas, insoluble lime salts may be deposited on the glass. If this is allowed to build up it becomes increasingly difficult to remove and looks unsightly. Regular cleaning will minimize this effect.

- Do not attempt to cut the glass.
 - Do not strike the glass with hard or pointed items.
 - Regularly check moving parts such as rollers and hinges to ensure they are secure and adjusted correctly. Tighten and adjust where required. Also check all sealed joints to ensure seal has not deteriorated. Re-seal if required.
-

FR

REMARQUE : Utilisez de l'eau tiède savonneuse et un chiffon doux humide pour garder la vitre propre. Si nécessaire, vous pouvez utiliser un produit pour vitres. Grattoirs, abrasifs et nettoyeurs chimiques peuvent endommager la vitre et le motif, et ne doivent ainsi pas être utilisés. Dans les zones dont l'eau est dure, un dépôt de calcaire peut se former sur la vitre. Si vous le laissez s'accumuler, il deviendra de plus en plus difficile à enlever, et sera inesthétique. Un nettoyage régulier permet de réduire cet effet.

- Ne tentez pas de découper la vitre.
 - Ne cognez pas la vitre avec des objets durs ou pointus.
 - Vérifiez régulièrement les pièces mobiles telles que les rouleaux et charnières afin de vous assurer qu'elles sont solidement fixées et correctement réglées. Serrez et ajustez-les lorsque nécessaire. Vérifiez également tous les joints scellés afin de vous assurer de l'intégrité de l'étanchéité. Scellez à nouveau au besoin.
-

PL

INFORMACJA: Użyj szmatki z ciepłą mydlaną wodą do czyszczenia szyb. Nie należy używać do czyszczenia ostrych zmywaków oraz szorujących lub chemicznych środków czyszczących, ponieważ mogą one uszkodzić szklaną powierzchnię lub wzór na szkło.

W twardej wodzie, nierozpuszczalne sole wapna mogą odkładać się na szybie. Jeśli nagromadzi się ich duża ilość, wówczas stają się one bardzo trudne do usunięcia. Regularne czyszczenie zminimalizuje ten efekt.

- Nie przecinaj szyb.
- Nie uderzaj w szyby twardymi lub spiczastymi przedmiotami.
- Regularnie sprawdzaj ruchome części, takie jak rolki ki i zawiasy, aby upewnić się, że są one bezpieczne i właściwie ustawione. Dokręć i wyreguluj je w razie potrzeby. Dodatkowo sprawdzaj wszystkie uszczelnione złącza, aby upewnić się, że uszczelnienie nie uległo pogorszeniu. Ponownie uszczelnij w razie potrzeby.

RO

NOTA: Utilizați apă caldă cu detergent și o cârpă moale pentru a menține geamul curat. Uscați ștergând cu o cârpă curată. Bureții abrazivi, produsele de curățat abrazive și chimice pot avaria sticla și aspectul acesteia, și nu ar trebui utilizate.

În zone cu apă dură, săruri insolubile de calcar se pot acumula pe sticlă. Dacă acestea sunt lăsate să se depoziteze, aceste acumulări pot deveni extrem de greu de îndepărtat și vor arăta neaspectuos. Curățarea periodică va minimiza acest efect.

- Nu încercați să tăiați sticla.
 - Nu loviți sticla cu articole ascuțite sau dure.
 - Verificați periodic piesele mobile precum roțile și balamalele pentru a vă asigura că sunt sigure și reglate corect. Strângeți și ajustați unde este nevoie. De asemenea verificați toate izolațiile de etanșeizare pentru a vă asigura că nu sunt deteriorate. Reizolați dacă este nevoie.
-

ES

NOTA: Use agua jabonosa tibia y un trapo húmedo suave para mantener el vidrio limpio. Seque con un trapo limpio- Las fibras, los limpiadores abrasivos y los químicos pueden dañar el vidrio y el dibujo, por lo que no deben usarse. En zonas de agua dura, las sales insolubles de cal pueden depositarse en el vidrio. Si se permite que se acumulen será cada vez más difícil retirarlas y se verá desagradable. La limpieza regular minimizará este efecto.

- No intente cortar el vidrio.
 - No golpee el vidrio con artículos duros o puntiagudos.
 - Compruebe con regularidad las partes móviles, como las ruedas y bisagras, para asegurarse de que están correctamente ajustadas. Apriételas y ajústelas cuando sea necesario. Compruebe también las juntas selladas para asegurarse de que el sellado no se ha deteriorado. Vuelva a sellarlo si fuera necesario.
-

PT

NOTA: Utilize água morna com sabão e um pano macio húmido para manter o vidro limpo. Limpe com um pano seco. Esfregões, substâncias abrasivas e substâncias químicas podem danificar o vidro e o padrão e não devem ser utilizados. Em zonas de água calcária, poderão depositar-se resíduos insolúveis no vidro. Se se forem acumulando, torna-se cada vez mais difícil removê-los e o vidro torna-se inestético. Uma limpeza regular minimiza este efeito.

- Não tente cortar o vidro.
- Não bata no vidro com objetos rígidos ou pontiagudos.
- Verifique regularmente as peças móveis, como os roletes e as dobradiças, para garantir que estão devidamente fixos e ajustados. Aperte e ajuste sempre que necessário. Verifique igualmente se as uniões vedadas não apresentam sinais de deterioração. Vede novamente, se necessário.



**Manufacturer • Fabricant • Producent •
Producător • Fabricante:**

UK Manufacturer:

Kingfisher International Products Limited,
1 Paddington Square, London, W2 1GG,
United Kingdom

EU Manufacturer:

Kingfisher International Products B.V.
Rapenburgerstraat 175E
1011 VM Amsterdam
The Netherlands
www.kingfisher.com/products
www.diy.com

EN www.screwfix.com
www.screwfix.ie

**To view instruction manuals online,
visit www.kingfisher.com/products**

FR www.castorama.fr
www.bricodepot.fr

**Pour consulter les manuels d'instructions en
ligne, rendez-vous sur le site
www.kingfisher.com/products**

PL www.castorama.pl

**Aby zapoznać się z instrukcją obsługi online,
odwiedź stronę
www.kingfisher.com/products**

RO www.bricodepot.ro

**Pentru a consulta manualele de instrucțiuni
online,
vizitați www.kingfisher.com/products**

ES www.bricodepot.es

**Para consultar los manuales
de instrucciones en línea, visite
www.kingfisher.com/product**

PT www.bricodepot.pt

**Para consultar manuais de instruções online,
visite www.kingfisher.com/products**