



Artwork done by Impala Services Ltd
info@impala-tech.com



SEPARATIONS	JOB INFO				
 PROCESS BLACK	PID #: 217797_s1_s3		Brand:		
	Agency Job #: PRJ23050		Brand Contact: Ronald Luo		
	Product Description:		Barcode: 5059340347387 / 5059340347165		
	Coffee Set 4		Vendor: MWH		
			No. of New Line Drawings:		
			Page Size: A4 / No. of Pages:		
	VERSION #				
	1	2	3	4	5
	18/08/21 William	01/09/21 William	31/08/21 NONE	31/08/21 NONE	31/08/21 NONE
This file is the property of Kingfisher Group Plc. No copying, alteration or amendment is permitted without written authorisation from the Kingfisher Brand Team.					
翠丰集团不会以专色(PMS)作参考，请参照已提供的印刷标准及Lab色彩数值生产以符合印刷品之标准。本文件的版权归翠丰集团所有。未经翠丰品牌团队的书面同意，不得对本文件进行复制、变更或修改。					

Apolima

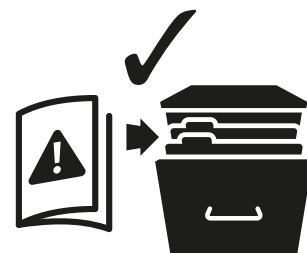

5059340347387 / 5059340347165



EN Safety

- For domestic use only.
- Always use on firm level ground.
- Periodic structural checks of this product should be undertaken, do not use if you have any doubts about its fitness for purpose.
- Do not sit or stand on the tabletop.
- Do not let children play with this product.
- This product must be set up by a competent adult.
- Do not use the glass as a chopping surface; do not strike the glass with hard or pointed items.
- Never place hot or cold items such as drink directly on the table surface, use a suitable tablemat.
- If the glass is chipped or broken, immediately replace with a tempered glass of the same dimensions (thickness, width & depth) which conforms to EN14072.
- When moving the table, do so using 2 adults and hold the frame tight to prevent the glass from falling out.
- Do not stand on the seat.
- Maximum load per seat: 100 kg.

At the beginning of the season

- Check to ensure that all components and fixings of this product are secure, do not use if you have any doubts about its fitness for purpose.

At the end of the season

- This product should be stored under cover during prolonged spells of adverse weather (wet or cold) and also during the winter (ideally in a garden shed or garage).
- Always clean and dry thoroughly before storage.

**IMPORTANT,
RETAIN FOR
FUTURE
REFERENCE: READ
CAREFULLY.**

FR Sécurité

- Usage domestique uniquement.
- À n'utiliser que sur un sol plat et ferme.
- Une vérification structurelle du produit doit être effectuée régulièrement. Ne pas utiliser en cas de doute sur l'aptitude à l'emploi.
- Ne pas s'asseoir ou se tenir debout sur la table.
- Ne pas laisser les enfants jouer avec ce produit.
- Ce produit doit être monté par un adulte compétent.
- Ne pas utiliser le verre comme une planche à découper et ne pas le heurter avec des objets durs ou pointus.
- Ne jamais placer d'objets chauds ou froids comme des boissons directement sur la surface de la table ; utiliser un set de table adapté.
- Si le verre est fêlé ou brisé, il convient de le remplacer immédiatement par un verre trempé de dimensions identiques (épaisseur, largeur et profondeur) et conforme à la norme EN14072.
- Pour déplacer la table, s'y prendre à deux adultes et tenir fermement la structure afin que le verre ne tombe pas.
- Ne pas se tenir debout sur le siège.
- Charge maximale par siège : 100 kg.

Au début de la saison

- Vérifier que tous les composants et fixations de ce produit sont bien en place. Ne pas utiliser le produit en cas de doute sur sa conformité à l'usage.

À la fin de la saison

- Ce produit doit être rangé sous une housse lors des périodes prolongées de mauvais temps (humide ou froid) et pendant l'hiver (idéalement dans un abri de jardin ou un garage).
- Toujours nettoyer et sécher complètement avant le remisage.

**IMPORTANT,
À CONSERVER
POUR RÉFÉRENCE
ULTÉRIEURE
ET À LIRE
ATTENTIVEMENT.**

PL Bezpieczeństwo

- Wyłącznie do użytku w gospodarstwie domowym.
- Zawsze ustawiać produkt na stabilnej, poziomej powierzchni.
- Okresowo sprawdzać integralność konstrukcji. W przypadku jakichkolwiek wątpliwości dotyczących przydatności produktu do określonego celu nie należy go użytkować.
- Nie siadać ani nie stawać na blacie.
- Nie pozwalać dzieciom bawić się produktem.
- Ten produkt wymaga ustawienia przez kompetentną osobę dorosłą.
- Szkła nie można używać jako powierzchni do siekania; nie uderzać w szkło twardymi lub szpiczastymi przedmiotami.
- Nigdy nie stawiać gorących lub zimnych przedmiotów, takich jak szklanki z napojami, bezpośrednio na powierzchni stołu. Używać odpowiednich podkładek.
- W przypadku odpryśnięcia lub pęknięcia szkła blat natychmiast wymienić na blat ze szkła hartowanego o tych samych wymiarach (grubość, szerokość i długość), spełniający wymagania normy EN14072.
- Stół może być przestawiany przez 2 osoby dorosłe. Mocno trzymać ramę, aby uniknąć wypadnięcia blatu szklanego.
- Nie stawać na siedzisku.
- Maksymalne obciążenie przypadające na siedzisko: 100 kg.



Na początku sezonu

- Należy upewnić się, że wszystkie elementy i mocowania tego produktu są bezpieczne. Nie używać w przypadku jakichkolwiek wątpliwości dotyczących jego przydatności do określonego celu.

Po zakończeniu sezonu

- Podczas dłuższych niekorzystnych warunków pogodowych (gdzie jest mokro lub zimno) oraz w zimie produkt należy przechowywać pod przykryciem (najlepiej w szopie lub garażu).
- Przed odłożeniem do przechowania należy zawsze dokładnie wyczyścić i osuszyć produkt.

WAŻNE: NALEŻY DOKŁADNIE PRZECZYTAĆ I ZACHOWAĆ W CELU WYKORZYSTANIA W PRZYSZŁOŚCI.

RO Siguranța

- Numai pentru uz casnic.
- A se utiliza întotdeauna pe teren plat și tare.
- Trebuie efectuate verificări structurale periodice pentru acest produs; nu îl folosiți dacă aveți îndoieli cu privire la adecvarea sa pentru scop.
- Nu stați în picioare sau în șezut pe blatul mesei.
- Nu lăsați copiii să se joace cu acest produs.
- Acest produs trebuie montat de către un adult competent.
- Nu utilizați sticla ca suprafață pentru tocare; nu loviți sticla cu elemente dure sau ascuțite.
- Nu așezați articole cu temperaturi ridicate sau scăzute, precum băuturi, direct pe suprafața mesei, utilizați un suport adecvat pentru farfurii.

- Dacă sticla este ciobită sau spartă, înlocuiți-o imediat cu sticlă securizată de aceleași dimensiuni (grosime, lățime și adâncime), care respectă standardul EN14072.
- Când mutați masa, implicați 2 adulți și țineți strâns cadrul pentru a împiedica sticla să cadă.
- Nu stați în picioare pe scaun.
- Sarcină maximă per loc: 100 kg.

La începutul sezonului

- Efectuați verificări pentru a vă asigura că toate componentele și elementele de fixare ale acestui produs sunt sigure și nu utilizați produsul dacă aveți îndoieli privind adecvarea sa pentru scop.

La sfârșitul sezonului

- Produsul trebuie depozitat acoperit în perioadele prelungite de vreme nefavorabilă (umiditate sau frig), precum și pe timp de iarnă (în mod ideal, într-o magazie din grădină sau într-un garaj).
- Curățați și uscați bine întotdeauna înainte de depozitare.

IMPORTANT - PĂSTRAȚI PENTRU CONSULTARE ULTERIOARĂ: CITIȚI CU ATENȚIE.

ES Seguridad

- Solo para uso doméstico.
- Coloque siempre el producto sobre un suelo firme y llano.
- Se deben llevar a cabo controles estructurales periódicos del producto. No lo utilice si tiene dudas sobre su idoneidad para el uso.
- No se siente ni se ponga de pie sobre la mesa.
- No deje que los niños jueguen con este producto.
- Este producto lo debe instalar un adulto competente.
- No utilice el cristal como superficie para cortar algo ni lo golpee con objetos duros o puntiagudos.
- Nunca coloque objetos calientes o

fríos, como bebidas, directamente sobre la superficie de la mesa: utilice siempre salvamanteles.

- Si el cristal se rompe o se casca, sustitúyalo de inmediato con un vidrio templado de las mismas dimensiones (espesor, anchura y profundidad) que sea acorde con la certificación EN14072.
- Para mover la mesa, se necesita la intervención de dos adultos que sostengan la estructura con firmeza para evitar que se caiga el cristal.
- No se ponga de pie en el asiento.
- Carga máxima por asiento: 100 kg.

Al principio de la temporada

- Compruebe que todos los componentes y fijaciones del producto son seguros. No lo utilice si duda sobre su idoneidad para el uso previsto.

Al final de la temporada

- Este producto debe guardarse a cubierto durante periodos prolongados con condiciones meteorológicas adversas (humedad o frío) y también durante el invierno (idealmente en una caseta o un garaje).
- Limpie y seque por completo el producto antes de guardarlo.

IMPORTANTE: GUARDE ESTA INFORMACIÓN PARA FUTURAS CONSULTAS. LÉALA ATENTAMENTE.



PT Segurança

- Exclusivo para uso doméstico.
- Utilize o produto sempre sobre o chão firme.
- Realize verificações estruturais periódicas deste produto; não utilize em caso de dúvida da sua adequação à finalidade.
- Não se sente nem fique de pé sobre o tampo da mesa.
- Não permita que as crianças brinquem com este produto.
- Este produto tem de ser configurado por um adulto.
- Não utilize o vidro como uma superfície de corte; não bata no vidro com itens duros ou pontiagudos.
- Nunca coloque itens quentes ou frios, tais como bebidas, diretamente na superfície da mesa; utilize uma proteção adequada.
- Se o vidro estiver lascado ou partido, substitua de imediato por um vidro temperado com as mesmas dimensões (espessura, largura e profundidade), em conformidade com a norma EN14072.
- São necessários dois adultos para mover a mesa e ao fazê-lo, prenda a estrutura com firmeza para evitar que o vidro caia.
- Não fique em pé sobre o assento.
- Carga máxima por assento: 100 kg.

No início da época

- Verifique para garantir que todos os componentes e fixações deste produto estão seguros. Não utilize se tiver dúvidas sobre a sua adequação para o efeito.

No final da época

- Este produto deve ser guardado devidamente coberto durante períodos longos de condições climáticas adversas (chuva ou frio) e também durante o inverno (preferivelmente em um abrigo de jardim ou garagem).
- Antes de armazenar, limpe e seque sempre com cuidado.

IMPORTANTE. GUARDE PARA REFERÊNCIA FUTURA: LEIA ATENTAMENTE.

TR Güvenlik

- Sadece evsel kullanıma yöneliktir.
- Daima sağlam düz bir zeminde kullanın.
- Bu ürünün düzenli yapı kontrolleri yapılmalıdır, amaca uygun olup olmadığına dair endişeniz varsa ürünü kullanmayın.
- Masanın üstüne oturmeyin veya çıkmayın.
- Çocukların bu ürünle oynamasına izin vermeyin.
- Bu ürün, yetkin bir yetişkin tarafından kurulmalıdır.
- Camı, kesme yüzeyi olarak kullanmayın; cama sert veya sivri eşyalarla vurmeyin.
- İçecek gibi sıcak veya soğuk eşyaları hiçbir zaman doğrudan masanın üzerine koymayın, uygun bir altlık kullanın.
- Cam kırılırsa camı derhal EN14072 ile uyumlu aynı ebatlarda (kalınlık, genişlik ve derinlik) bir temperli camla değiştirin.
- Masayı 2 yetişkin taşımalıdır ve camın düşmesini engellemek için çerçeve sıkı tutulmalıdır.
- Koltuğun üzerine çıkmayın.
- Koltuk başına maksimum yük: 100 kg.

Mevsim başlangıcında

- Bu ürünün tüm bileşenlerinin ve bağlantı elemanlarının sağlam olduğundan emin olun; amacına uygun olup olmadığına dair bir şüphenez varsa ürünü kullanmayın.

Mevsim sonunda

- Bu ürün, uzun süreli olumsuz hava koşullarında (ıslak veya soğuk) ve kış mevsiminde kapalı ortamda saklanmalıdır (tercihen bir bahçe kulübesinde veya garajda).
- Saklamadan önce her zaman iyice temizleyin ve kurutun.

ÖNEMLİ, İLERİDE BAŞVURMAK ÜZERE SAKLAYIN: DİKKATLİCE OKUYUN.

- Manufacturer • Fabricant • Producent • Producător • Fabricante:**
UK Manufacturer:
Kingfisher International Products Limited,
3 Sheldon Square, London, W2 6PX,
United Kingdom
EU Manufacturer:
Kingfisher International Products B.V.
Rapenburgerstraat 175E
1011 VM Amsterdam
The Netherlands
www.kingfisher.com/products
- EN** www.diy.com
www.screwfix.com
www.screwfix.ie
**To view instruction manuals online,
visit www.kingfisher.com/products**
- FR** www.castorama.fr
www.bricodepot.fr
**Pour consulter les manuels d'instructions
en ligne, rendez-vous sur le site
www.kingfisher.com/products**
- PL** www.castorama.pl
**Aby zapoznać się z instrukcją obsługi online,
odwiedź stronę www.kingfisher.com/products**
- RO** www.bricodepot.ro
**Pentru a consulta manualele de instrucțiuni online,
vizitați www.kingfisher.com/products**
- ES** www.bricodepot.es
**Para consultar los manuales de instrucciones
en línea, visite www.kingfisher.com/products**
- PT** www.bricodepot.pt
**Para consultar manuais de instruções online,
visite www.kingfisher.com/products**
- TR** **İthalatçı Firma:**
KOÇTAŞ YAPI MARKETLERİ TİC. A.Ş.
Taşdelen Mah. Sırrı Çelik Bulvarı No:5
34788 Taşdelen/Çekmeköy/İSTANBUL
Tel: +90 216 4300300
Faks: +90 216 4844313
www.koctas.com.tr
**Kullanım kılavuzuna internet üzerinden ulaşmak
için www.kingfisher.com/products adresini
ziyaret edin**
Yetkili servis istasyonları ve yedek parça temini için
aşağıda yer alan Koçtaş Müşteri Hattı ve Koçtaş Genel
Müdürlük irtibat bilgilerinden faydalanınız.
KOÇTAŞ MÜŞTERİ HİZMETLERİ
0850 209 50 50

Apolima

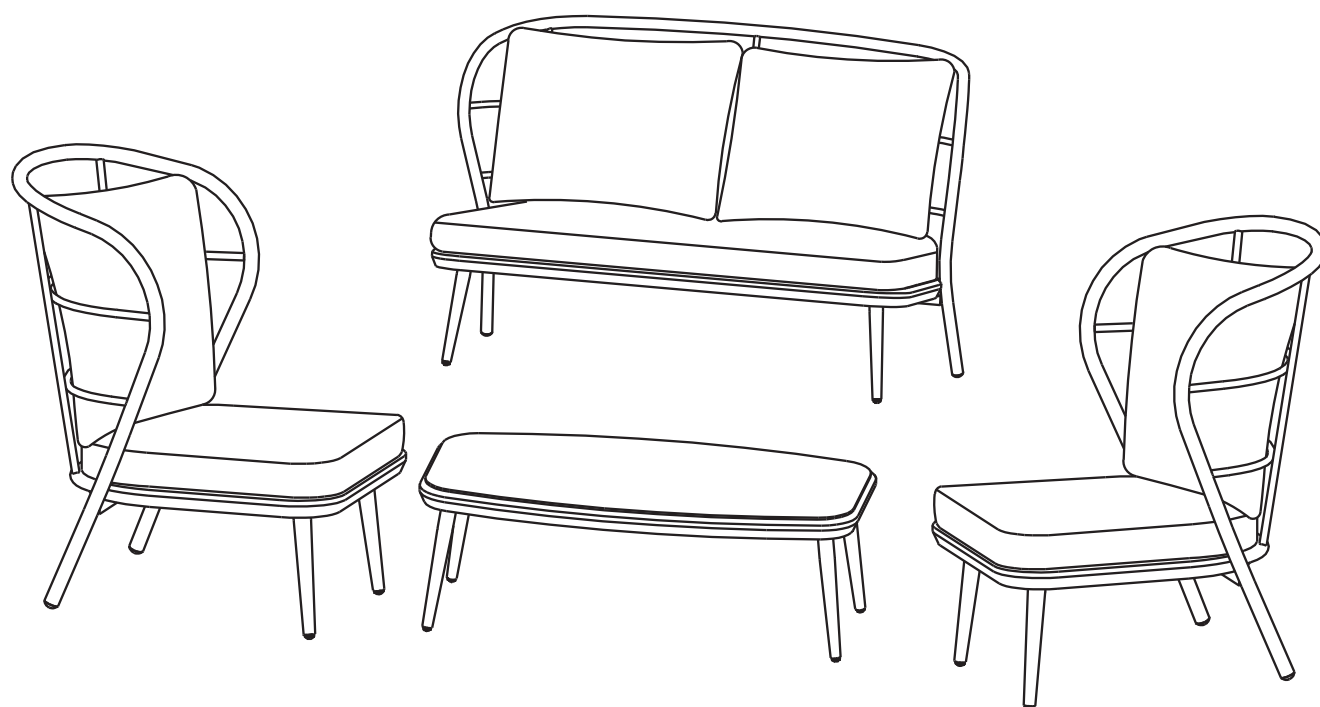
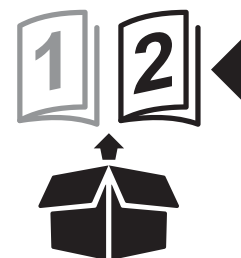

5059340347387 / 5059340347165



EN	Contents	FR	Contenu	PL	Zawartość	RO	Cuprins	2
ES	Contenido	PT	Conteúdo	TR	İçindekiler			



Installation

4

FR	Installation	4
PL	Instalacja	4
RO	Instalare	4
ES	Instalación	4
PT	Instalação	4
TR	Kurulum	4



Care

8

FR	Entretien	8
PL	Czyszczenie	8
RO	Îngrijire	8
ES	Cuidados	8
PT	Cuidados	8
TR	Bakım	8



EN IMPORTANT - Please read carefully the separate safety guide before use.

FR IMPORTANT - Lire attentivement le guide de sécurité séparé avant utilisation.

PL WAŻNE - Przed użyciem proszę dokładnie zapoznać się z instrukcją bezpieczeństwa.

RO IMPORTANT - Vă rugăm să citiți cu atenție ghidul de siguranță separat înainte de utilizare.

ES IMPORTANTE - Lea atentamente la guía de seguridad separado antes de utilizar.

PT IMPORTANTE - Leia atentamente o guia de segurança separado antes de usar.

TR ÖNEMLI - Kullanmadan önce emniyet kurallarını lütfen dikkatle okuyun.

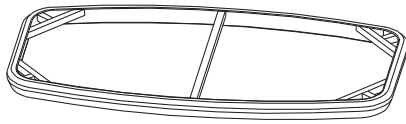
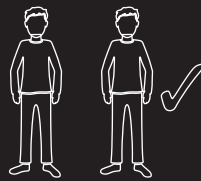

[01] x 1



[02] x 4

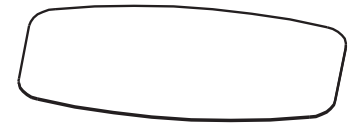

[03] x 1

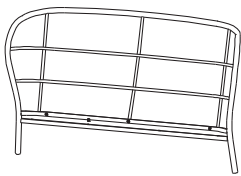

[04] x 1

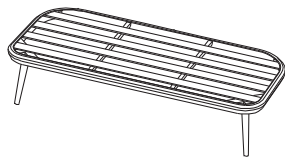

[05] x 1

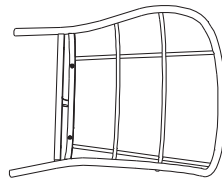

[06] x 2



[07] x 2

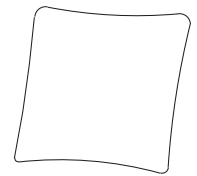

[08] x 4



[09] x 1



[10] x 2



[11] x 12
M6 x 20



[12] x 12



[13] x 7
M8 x 40

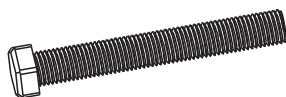

[14] x 10
M8 x 60



[15] x 17

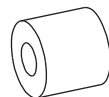

[16] x 4



[17] x 17



[18] x 1

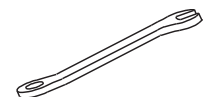

[19] x 1



EN
ES

Installation
Instalación

FR
PT

Installation
Instalação

PL
TR

Instalacja
Kurulum

RO

Instalare

01



[01] x 1



[02] x 4

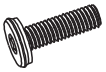

[11] x 12



[12] x 12



[18] x 1

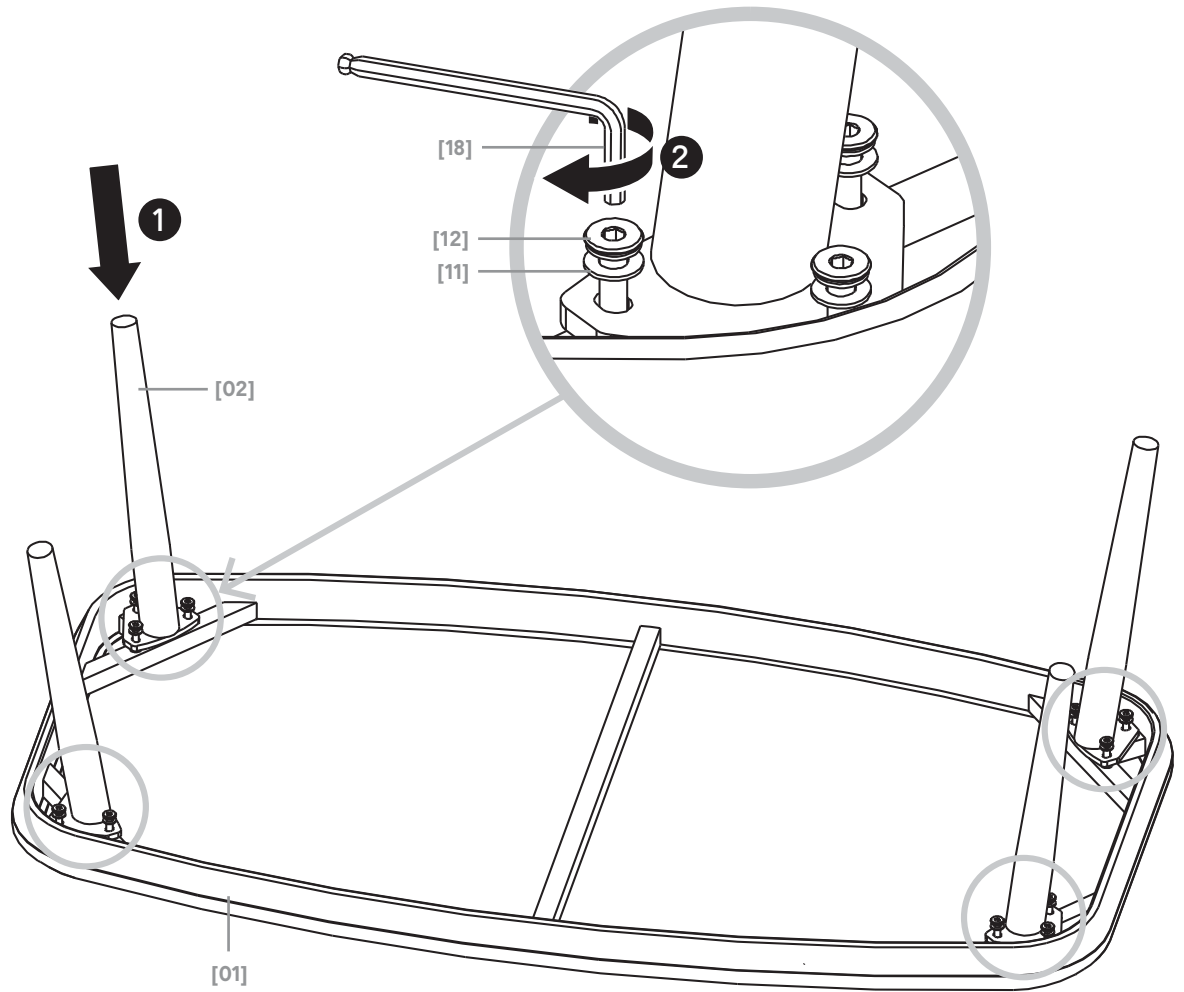

02

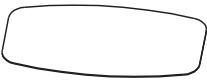

[03] x 4

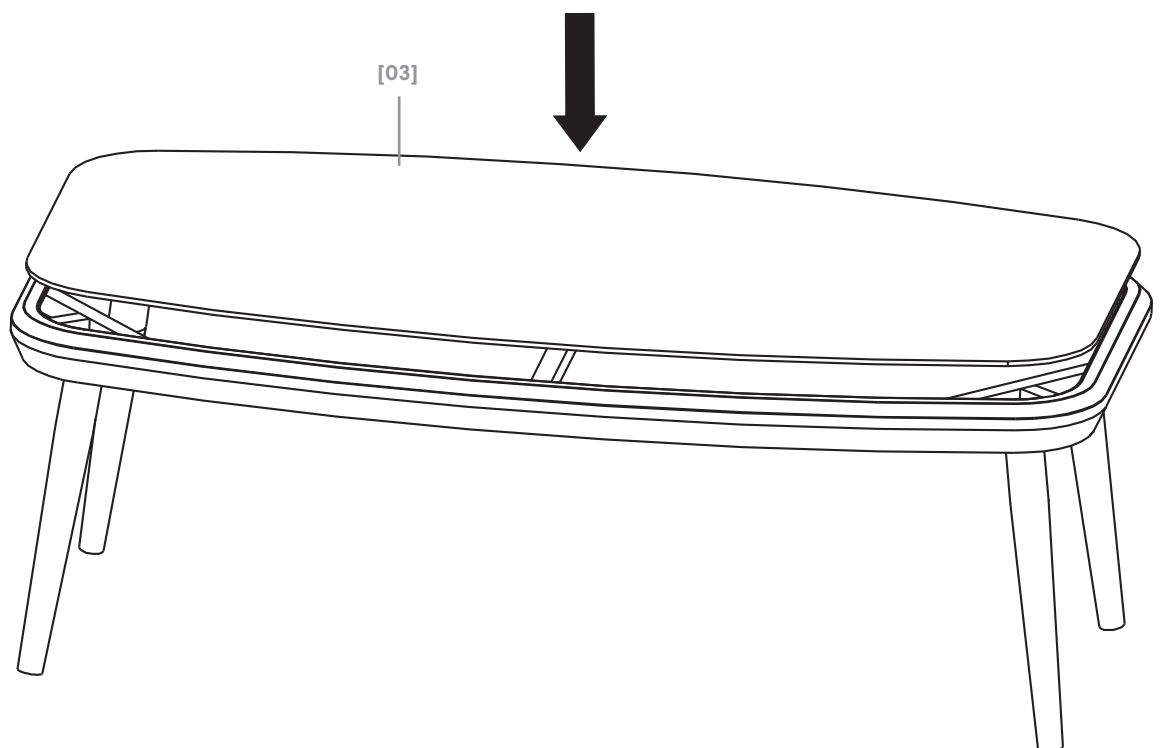



EN
ES

Installation
Instalación

FR
PT

Installation
Instalação

PL
TR

Instalacja
Kurulum

RO Instalare

03

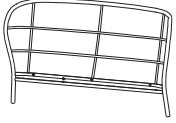

[04] x 1



[05] x 1



[13] x 3



[15] x 3



[17] x 3

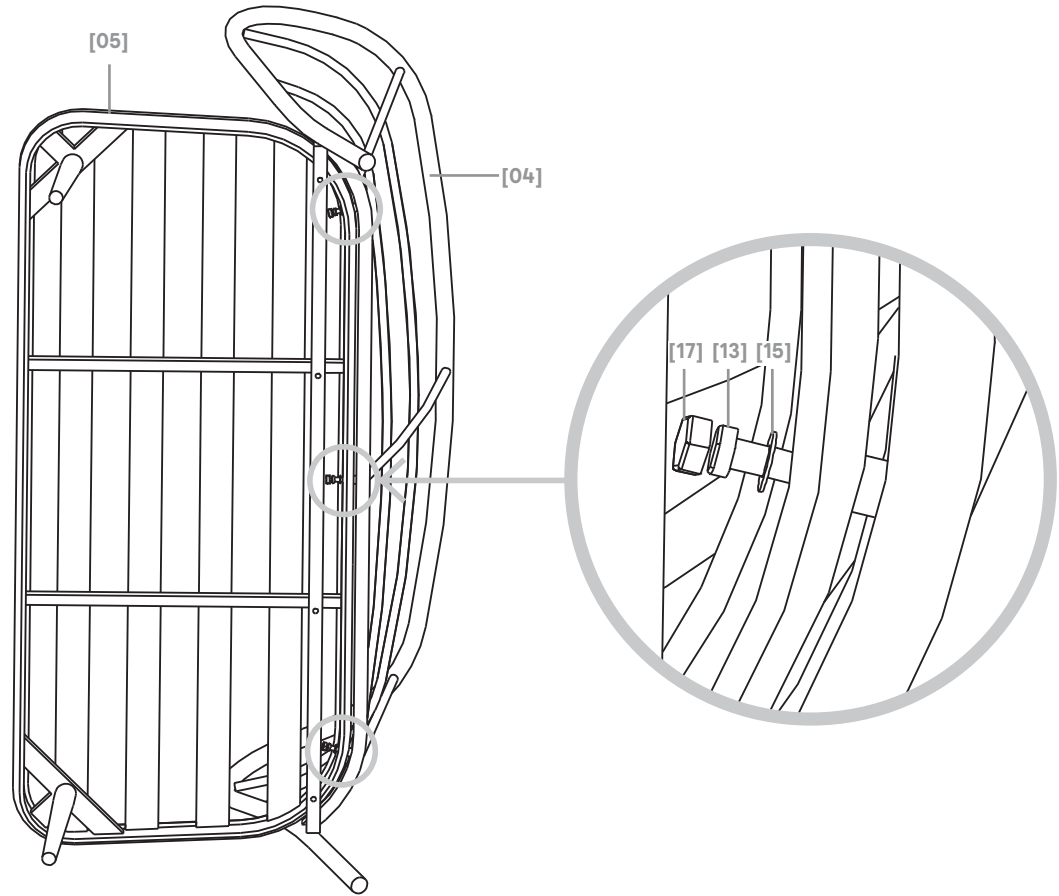

04



[14] x 4



[15] x 4

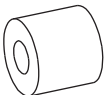

[16] x 2



[17] x 4

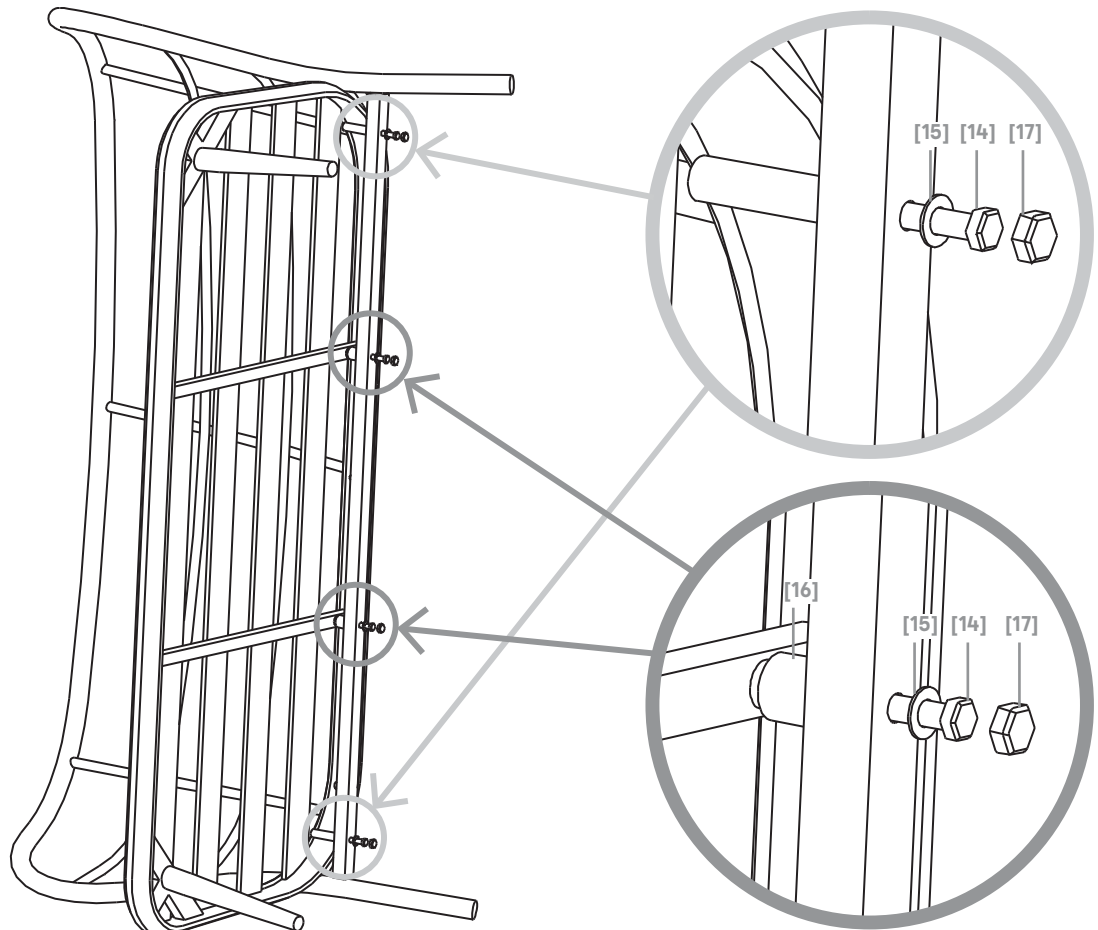



EN
ES

Installation
Instalación

FR
PT

Installation
Instalação

PL
TR

Instalacja
Kurulum

RO

Instalare

05

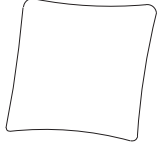

[08] x 2



[09] x 1

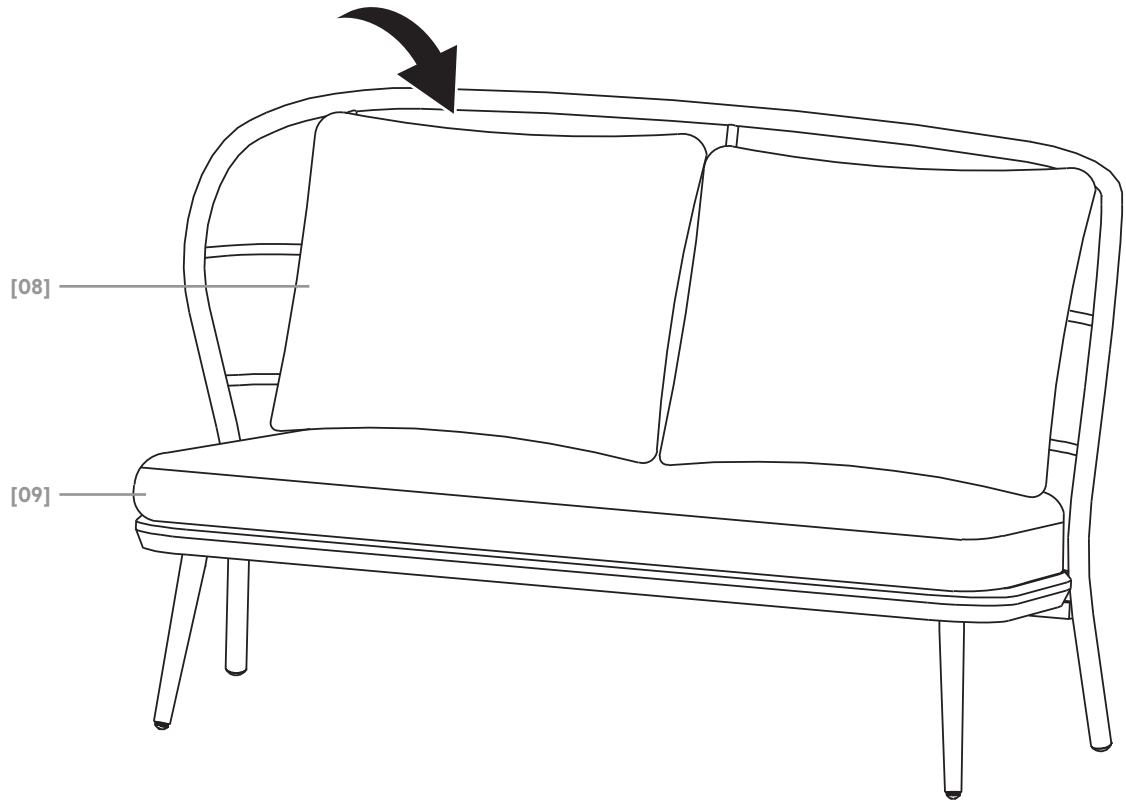

06

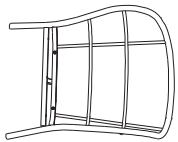

[06] x 2



[07] x 2



[13] x 4



[15] x 4



[17] x 4

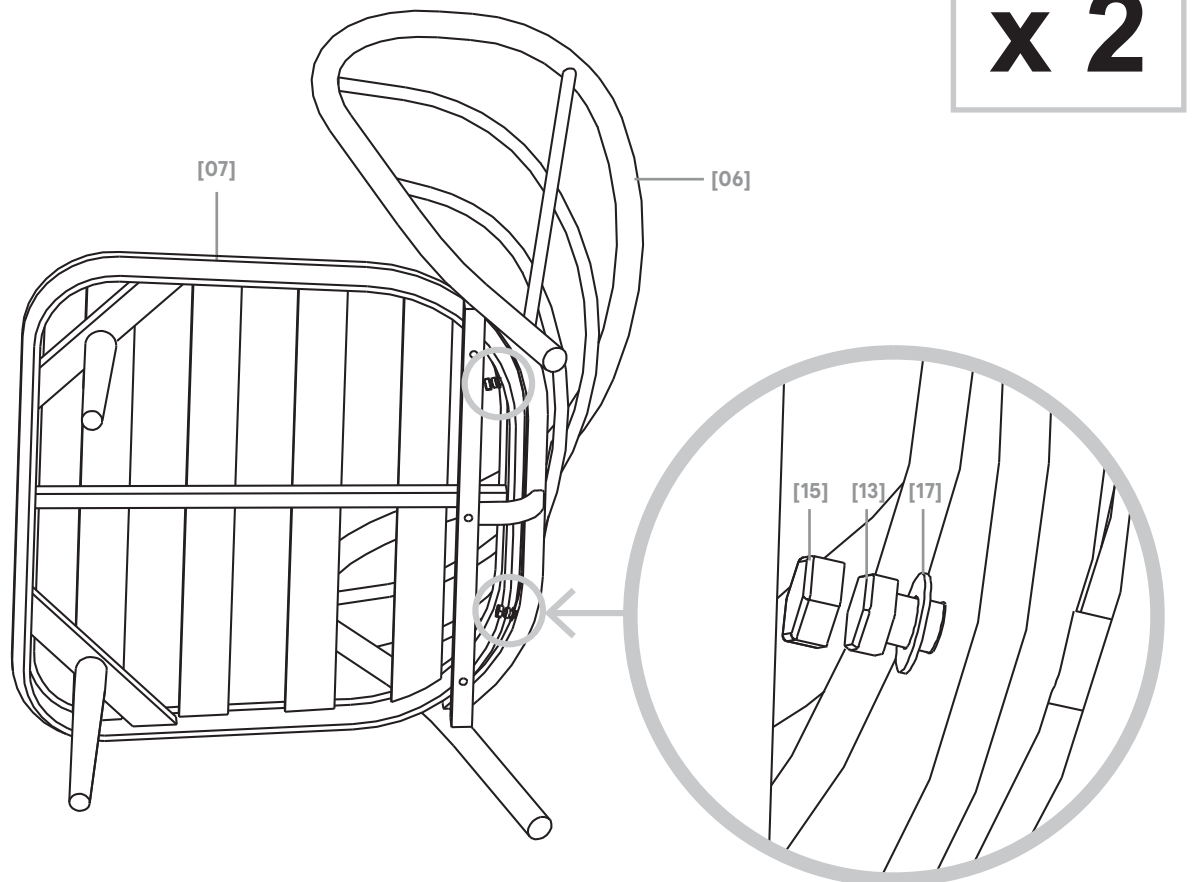



EN
ES

Installation
Instalación

FR
PT

Installation
Instalação

PL
TR

Instalacja
Kurulum

RO

Instalare

7

07



[14] x 6



[15] x 6

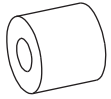

[16] x 2



[17] x 6

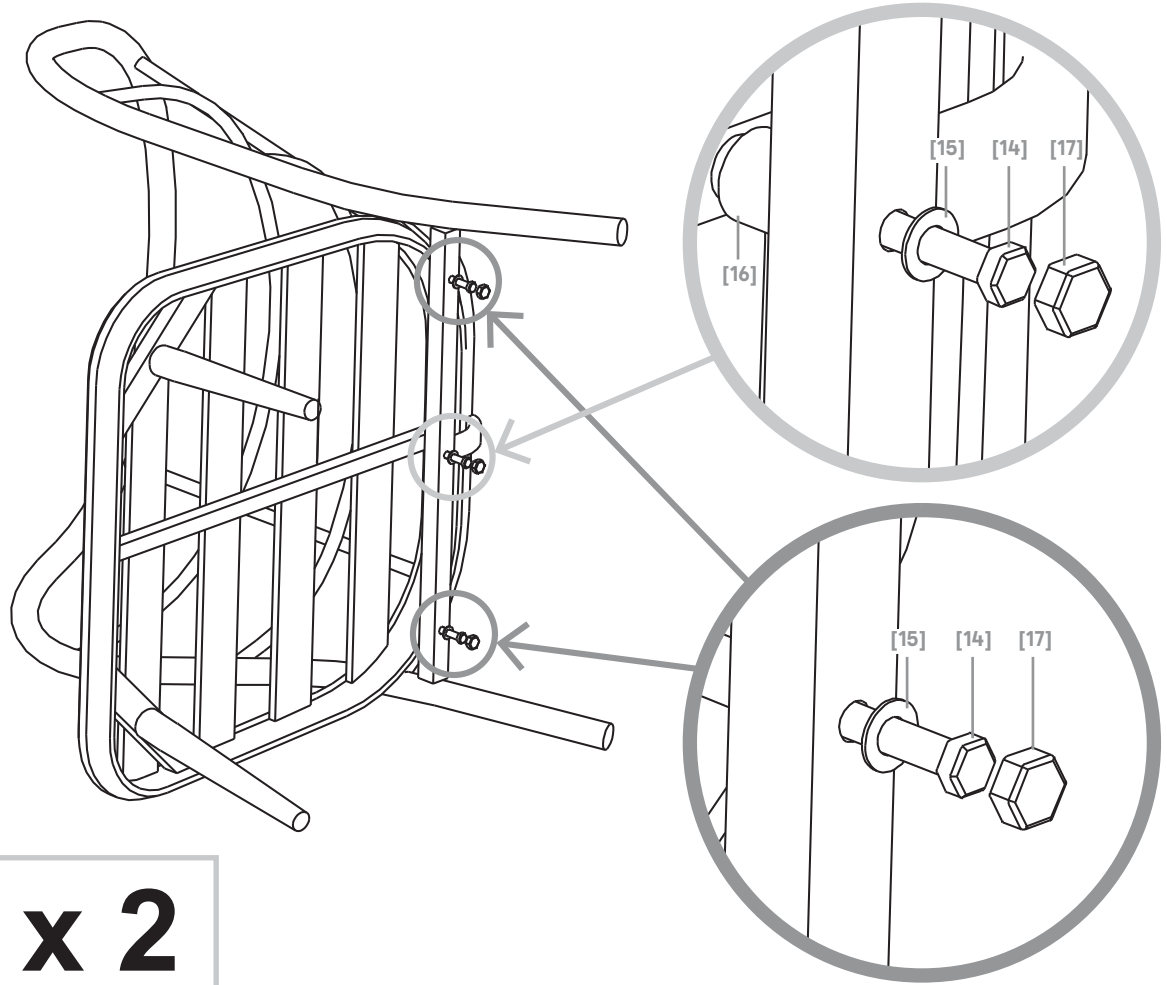

x 2

08

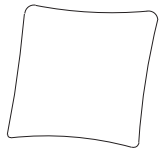

[08] x 2



[10] x 2

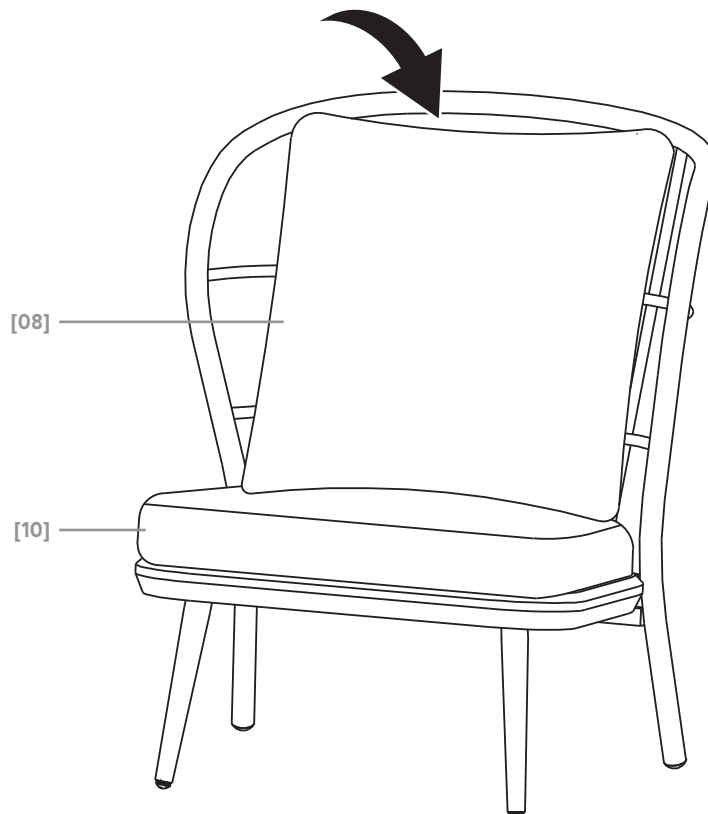

x 2

