



Artwork done by Impala Services Ltd
info@impala-tech.com



SEPARATIONS	JOB INFO			
 PROCESS BLACK	PID #: 217797_s1_s18 Agency Job #: Product Description: Oneshot2021-8 Bahama Dining Set	Brand: Brand Contact: Ronald Luo Barcode: 5059340136707 Vendor: MWH No. of New Line Drawings: Page Size: A4 / No. of Pages:		
VERSION #				
1 26/08/21 Sonia	2 31/08/21 NONE	3 31/08/21 NONE	4 31/08/21 NONE	5 31/08/21 NONE
<p>This file is the property of Kingfisher Group Plc. No copying, alteration or amendment is permitted without written authorisation from the Kingfisher Brand Team.</p> <p>翠丰集团不会以专色(PMS)作参考，请参照已提供的印刷标准及Lab色彩数值生产以符合印刷品之标准。本文件的版权归翠丰集团所有。未经翠丰品牌团队的书面同意，不得对本文件进行复制、变更或修改。</p>				

Bahama

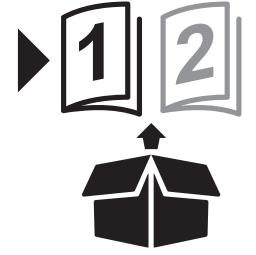

5059340136707

**EN Safety**

- For domestic use only.
- Take care when opening and closing this product and keep hands away from the folding mechanisms to prevent fingers being trapped and pinched.
- Always use on firm level ground.
- Periodic structural checks of this product should be undertaken, do not use if you have any doubts about its fitness for purpose.
- Do not stand on the seat.
- Do not sit in the armrest.
- Do not sit or stand on the tabletop.
- Do not let children play with this product.
- This product must be set up by a competent adult.
- Do not use the parasol without a suitable parasol base.
- Keep away from naked flames and direct sources of heat such as patio heaters and barbecues.
- Never stay under this product in thunderstorms.
- Do not hang from the ribs, frame and canopy of this product.
- This product is designed for occasional use only. This is not to be used as a permanent structure and must be protected from adverse weather conditions such as high winds, heavy rain and snow. Do not use in such conditions. Dismantle and store safely to prevent any damage occurring.
- Pregnant women shall take extra care when using this product.
- Maximum load: 100kg

At the beginning of the season

- Check to ensure that all components and fixings of this product are secure, do not use if you have any doubts about its fitness for purpose.

At the end of the season

- This product should be stored under cover during prolonged spells of adverse weather (wet or cold) and also during the winter (ideally in a garden shed or garage).
- Always clean and dry thoroughly before storage.

IMPORTANT, RETAIN FOR FUTURE REFERENCE: READ CAREFULLY.

FR Sécurité

- Pour un usage domestique uniquement.
- Lors de l'ouverture et de la fermeture du produit, veiller à tenir les mains à l'écart des mécanismes pliants afin d'éviter tout coincement et pincement de doigts.
- Toujours utiliser sur un sol plat et ferme.
- Une vérification de l'état du produit doit être régulièrement effectuée. Ne pas utiliser le produit en cas de doute sur sa conformité à l'usage.
- Ne pas se tenir debout sur l'assise.
- Ne pas s'asseoir sur l'accoudoir.
- Ne pas s'asseoir ou se tenir debout sur la table.
- Ne pas laisser les enfants jouer avec ce produit.
- Ce produit doit être monté par un adulte compétent.
- Ne pas utiliser le parasol sans un pied de parasol adapté.
- Tenir à l'écart des flammes nues et des sources directes de chaleur comme les parasols chauffants et les barbecues.
- Ne jamais rester sous ce produit en cas d'orage.
- Ne pas se suspendre aux baleines, à la structure ou à la toile de ce produit.
- Ce produit est conçu pour un usage occasionnel. Il ne doit pas être utilisé comme une structure permanente et doit être protégé contre les intempéries telles que les vents violents, les fortes pluies et la neige. Ne pas utiliser le produit dans ces conditions. Démonter et ranger le produit dans un endroit sûr afin d'éviter tout dommage.
- Les femmes enceintes doivent redoubler de vigilance lors de l'utilisation de ce produit.
- Charge maximale : 100kg

En début de saison

- Vérifiez que tous les composants et fixations de ce produit soient

fermement serrés. En cas de doute, ne l'utilisez pas.

En fin de saison

- L'hiver ou en cas d'intempéries prolongées, il est recommandé de ranger ce produit dans un garage ou une pièce aérée sans chauffage. Ne le couvrez pas.
- Nettoyez et séchez toujours le produit avant de le ranger.

IMPORTANT – A CONSERVER POUR DE FUTURS BESOINS DE REFERENCE : A LIRE SOIGNEUSEMENT.

PL Bezpieczeństwo

- Wyłącznie do użytku w gospodarstwie domowym.
- Podczas składania i rozkładania produktu należy zachować ostrożność i trzymać ręce z dala od mechanizmów składania, aby uniknąć przytrzaśnięcia i przycięcia palców.
- Zawsze ustawiać produkt na stabilnej, poziomej powierzchni.
- Należy okresowo sprawdzać stan produktu, a w przypadku jakichkolwiek wątpliwości dotyczących przydatności do określonego celu nie należy go użytkować.
- Nie należy stawać na siedzisku.
- Nie należy siadać na podłokietnikach.
- Na blacie stołu nie należy siadać ani stawać.
- Nie należy pozwalać dzieciom bawić się produktem.
- Rozstawienie produktu należy powierzyć osobie kompetentnej.
- Nie używać parasola bez odpowiedniej podstawy.
- Trzymać z dala od otwartego ognia i źródeł ciepła takich jak ogrzewacze tarasowe i grille.
- Nigdy nie przebywać pod tym produktem w czasie burzy.
- Nie wieszać niczego na ramionach, stelażu ani czaszy produktu.



- Produkt jest przeznaczony wyłącznie do okazjonalnego użytkowania. Nie jest przeznaczony do stosowania jako konstrukcja stała i należy zabezpieczyć go przed niekorzystnymi warunkami pogodowymi, takimi jak silny wiatr, ulewny deszcz czy śnieg. W przypadku wystąpienia takich warunków nie należy używać produktu. Produkt należy zdemontować i przechowywać w bezpiecznym miejscu, aby zapobiec jego uszkodzeniu.
- Podczas użytkowania tego produktu kobiety w ciąży powinny zachować szczególną ostrożność.
- Maksymalne obciążenie: 100 kg

Na początku sezonu

- Przed użyciem proszę upewnić się, że wszystkie części i elementy montażowe zostały prawidłowo przymocowane. Nie używaj produktu, jeśli masz jakiegokolwiek wątpliwości na temat ich przydatności do użycia.

Na końcu sezonu

- Niniejszy produkt powinien być przykryty pokrowcem podczas jego przechowywania, jeśli nie zamierzone jest jego użycie przez dłuższy okres czasu lub podczas złych warunków atmosferycznych (opady deszczu lub niska temperatura otoczenia) oraz podczas zimy (najlepiej przechowywać w schowku lub w garażu).
- Zawsze wyczyść i osusz produkty przed przechowywaniem.

WAŻNE – NALEŻY DOKŁADNIE PRZECZYTAĆ NINIEJSZE INFORMACJE I ZACHOWAĆ.

RO Siguranța

- Numai pentru uz casnic.
- Ai grijă atunci când desfaci și strângi produsul și ține mâinile departe de mecanismele de pliere, pentru a preveni prinderea și rănirea degetelor.

- A se utiliza întotdeauna pe teren plat și tare.
- Trebuie efectuate verificări structurale periodice ale acestui produs; nu folosi produsul dacă nu ești sigur că este adecvat pentru utilizare.
- Nu sta în picioare pe șezut.
- Nu te așeza pe cotiere.
- Nu sta în picioare sau în șezut pe blatul mesei.
- Nu lăsa copiii să se joace cu acest produs.
- Acest produs trebuie montat de către o persoană competentă.
- Nu folosi umbrela de soare fără o bază potrivită.
- Ține departe de flăcări deschise sau surse directe de căldură, precum încălzitoare pentru curte interioară și grătare.
- Nu te adăposti sub acest produs în timpul furtunilor.
- Nu te agăța de spițele, cadrul și copertina acestui produs.
- Acest produs este destinat exclusiv pentru uz ocazional. A nu se utiliza ca structură permanentă; a se proteja de condițiile meteorologice nefavorabile, precum vânt puternic, ploaie torențială și zăpadă. A nu se utiliza în astfel de condiții. Dezassemblează și depozitează în siguranță pentru a preveni deteriorarea.
- Femeile însărcinate trebuie să acorde atenție deosebită atunci când utilizează acest produs.
- Sarcină maximă: 100 kg

La începutul sezonului

- Verificați pentru a vă asigura că toate componentele și dispozitivele de prindere ale acestui produs sunt sigure și nu îl folosiți dacă aveți îndoieli asupra capacității lui, de exemplu.

La sfârșitul sezonului

- Acest produs trebuie depozitată acoperită în timpul perioadelor lungi de vreme nefavorabilă (umezeală sau frig) și de asemenea în timpul iernii (ideal într-o baracă de grădină sau în garaj).
- Curățați și uscați bine înainte de depozitare.

IMPORTANT – PĂSTRAȚI ACESTE INFORMAȚII PENTRU REFERINȚE VIITOARE: CITIȚI CU ATENȚIE.

ES Seguridad

- Solo para uso doméstico.
- Tenga cuidado al abrir y cerrar este producto. Mantenga las manos alejadas de los mecanismos de plegado para evitar que los dedos queden atrapados y aplastados.
- Coloque siempre el producto sobre un suelo firme y plano.
- Se deben llevar a cabo controles estructurales periódicos del producto. No lo utilice si tiene dudas sobre su idoneidad para el uso.
- No se ponga de pie en el asiento.
- No se siente en el brazo.
- No se siente ni se ponga de pie sobre la mesa.
- No deje que los niños jueguen con este producto.
- Este producto lo debe instalar un adulto competente.
- No utilice un parasol sin una base apropiada.
- Aléjelo de las llamas y de cualquier otra fuente directa de calor, como barbacoas o calefactores.
- No permanezca bajo este producto durante tormentas eléctricas.
- No se cuelgue de las varillas, la estructura ni el toldo.
- Este artículo se ha diseñado para usarlo de modo esporádico. No debe utilizarse como estructura permanente y hay que protegerlo de los fenómenos meteorológicos adversos, como vientos fuertes, lluvia intensa y nieve. No puede utilizarse si se dan esas condiciones. En esas circunstancias, desmonte y guarde el producto con cuidado para evitar que sufra daños.
- Las mujeres embarazadas deben tener especial cuidado al usar este producto.
- Carga máxima: 100 kg



Al principio de la temporada

- Revise el producto para asegurarse de que todos los componentes y accesorios están bien fijados y sujetos, no lo utilice si tiene alguna duda sobre el estado o el uso del producto.

Al final de la temporada

- Este producto debe guardarse bajo cubierto durante largos periodos de mal tiempo o condiciones meteorológicas adversas (de frío o lluvia) y también durante el invierno (preferentemente en un garaje o trastero).
- Siempre limpie y seque a fondo el producto antes de almacenarlo.

IMPORTANTE – GUARDE ESTA INFORMACIÓN PARA FUTURAS CONSULTAS: LEA ATENTAMENTE.

PT : Segurança

- Exclusivo para uso doméstico.
- Tenha cuidado ao abrir e fechar este produto; mantenha as mãos afastadas dos mecanismos de dobra, para evitar que os dedos fiquem entalados e trilhados.
- Utilize o produto sempre sobre o chão firme.
- Realize verificações estruturais periódicas deste produto; não utilize em caso de dúvida da sua adequação à finalidade.
- Não fique em pé sobre o assento.
- Não se sente sobre os braços.
- Não se sente nem fique de pé sobre o topo da mesa.
- Não permita que as crianças brinquem com este produto.
- Este produto tem de ser configurado por um adulto.
- Não utilize o guarda-sol sem uma base de guarda-sol adequada.
- Mantenha afastado de chamas desprotegidas e fontes de calor diretas, tais como aquecedores para pátios e grelhadores.

- Nunca permaneça por baixo deste produto durante tempestades.
- Não se pendure nas hastes, estrutura e toldo deste produto.
- Este produto foi concebido apenas para utilização ocasional. Não deve ser utilizado como uma estrutura permanente e tem de ser protegido contra condições atmosféricas adversas, como ventos fortes, chuva intensa e neve. Não o utilize sob estas condições. Desmonte-o e guarde-o em segurança para evitar a ocorrência de danos.
- As mulheres grávidas devem ter muito cuidado ao utilizar este produto.
- Carga máxima: 100 kg

No princípio da temporada

- Faça uma revisão do produto para garantir que todos os componentes e acessórios estão bem fixos e seguros, não utilize se tiver alguma dúvida sobre o estado ou a utilização deste produto.

No final da temporada

- Este produto deve ser guardado num local coberto durante longos períodos de mau tempo ou condições meteorológicas adversas (de frio ou chuva) e também durante o inverno (preferivelmente numa garagem ou arrecadação).
- Limpe e seque sempre a fundo o produto antes de guardá-lo.

IMPORTANTE – CONSERVE ESTE MANUAL PARA FUTURAS CONSULTAS: LEIA ATENTAMENTE.

TR : Güvenlik

- Sadece evde kullanıma yöneliktir.
- Bu ürünü açıp kapatırken dikkatli olun ve parmaklarınızın sıkışıp ezilmesini önlemek için ellerinizi katlama mekanizmalarından uzak tutun.
- Daima sağlam düz bir zeminde kullanın.
- Bu ürünün düzenli yapı kontrolleri yapılmalıdır, amaca uygun olup

- olmadığına dair endişeniz varsa ürünü kullanmayın.
- Koltuğun üzerine çıkmayın.
- Kolçağa oturmayın.
- Masanın üstüne oturmayın veya çıkmayın.
- Çocukların bu ürünle oynamasına izin vermeyin.
- Bu ürün, yetkin bir yetişkin tarafından kurulmalıdır.
- Uygun bir şemsiye tabanı olmadan şemsiye kullanmayın.
- Çıplak alevden ve veranda ısıtıcıları ve barbeküler gibi doğrudan ısı kaynaklarından uzak tutun.
- Gök gürültülü ve fırtınalı havalarda asla bu ürünün altında durmayın.
- Bu ürünü; iskeletinden, çerçevesinden ve kanopisinden asmayın.
- Bu ürün yalnızca nadir kullanım için tasarlanmıştır. Bu ürün, kalıcı bir eşya olarak kullanılmamalıdır ve şiddetli rüzgar, şiddetli yağmur ve kar gibi olumsuz hava koşullarından korunmalıdır. Belirtilen koşullarda kullanmayın. Hasar görmemesi için sökün ve güvenli bir şekilde saklayın.
- Hamile kadınlar bu ürünü kullanırken ekstra özen göstermelidir.
- Maksimum yük: 100 kg

Sezon başlarken

- Bu ürünün tüm parçaları ve donanımlarının güvenli olduğundan emin olun, amaca uygun kullanımı ile ilgili şüphe olması durumunda kullanmayın.

Sezon biterken

- Bu ürün, uzun süreli kötü hava şartlarında (yağmur veya soğuk) ve kış boyunca üzerine örtü örtülerek muhafaza edilmelidir (ideal olarak bahçedeki bir baraka veya garajda).
- Muhafaza etmeden önce daima temizleyin ve iyice kurulaştırın.

ÖNEMLİ – BU BİLGİLERİ DAHA SONRA KULLANMAK ÜZERE SAKLAYIN: DİKKATLE OKUYUN.

- Manufacturer • Fabricant • Producent • Producător • Fabricante:**
UK Manufacturer:
Kingfisher International Products Limited,
3 Sheldon Square, London, W2 6PX,
United Kingdom
EU Manufacturer:
Kingfisher International Products B.V.
Rapenburgerstraat 175E
1011 VM Amsterdam
The Netherlands
www.kingfisher.com/products
- EN** www.diy.com
www.screwfix.com
www.screwfix.ie
**To view instruction manuals online,
visit www.kingfisher.com/products**
- FR** www.castorama.fr
www.bricodepot.fr
**Pour consulter les manuels d'instructions
en ligne, rendez-vous sur le site
www.kingfisher.com/products**
- PL** www.castorama.pl
**Aby zapoznać się z instrukcją obsługi online,
odwiedź stronę www.kingfisher.com/products**
- RO** www.bricodepot.ro
**Pentru a consulta manualele de instrucțiuni online,
vizitați www.kingfisher.com/products**
- ES** www.bricodepot.es
**Para consultar los manuales de instrucciones
en línea, visite www.kingfisher.com/products**
- PT** www.bricodepot.pt
**Para consultar manuais de instruções online,
visite www.kingfisher.com/products**
- TR** **İthalatçı Firma:**
KOÇTAŞ YAPI MARKETLERİ TİC. A.Ş.
Taşdelen Mah. Sırrı Çelik Bulvarı No:5
34788 Taşdelen/Çekmeköy/İSTANBUL
Tel: +90 216 4300300
Faks: +90 216 4844313
www.koctas.com.tr
**Kullanım kılavuzuna internet üzerinden ulaşmak
için www.kingfisher.com/products adresini
ziyaret edin**
Yetkili servis istasyonları ve yedek parça temini için
aşağıda yer alan Koçtaş Müşteri Hattı ve Koçtaş Genel
Müdürlük irtibat bilgilerinden faydalanınız.
KOÇTAŞ MÜŞTERİ HİZMETLERİ
0850 209 50 50

Bahama



5059340136707



EN	Contents	FR	Contenu	PL	Zawartość
RO	Cuprins	ES	Contenido	PT	Conteúdo
TR	İçindekiler				

2



Installation

4

FR	Installation	4
PL	Instalacja	4
RO	Instalare	4
ES	Instalación	4
PT	Instalação	4
TR	Kurulum	4



Care

8

FR	Entretien	8
PL	Czyszczenie	8
RO	Îngrijire	8
ES	Cuidados	8
PT	Cuidados	8
TR	Bakım	8



EN IMPORTANT - Please read carefully the separate safety guide before use.

FR IMPORTANT - Lire attentivement le guide de sécurité séparé avant utilisation.

PL WAŻNE - Przed użyciem proszę dokładnie zapoznać się z instrukcją bezpieczeństwa.

RO IMPORTANT - Vă rugăm să citiți cu atenție ghidul de siguranță separat înainte de utilizare.

ES IMPORTANTE - Lea atentamente la guía de seguridad separado antes de utilizar.

PT IMPORTANTE - Leia atentamente o guia de segurança separado antes de usar.

TR ÖNEMLİ - Kullanmadan önce emniyet kurallarını lütfen dikkatle okuyun.

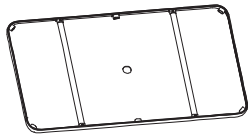
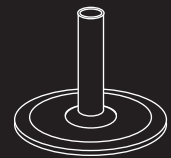
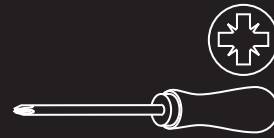
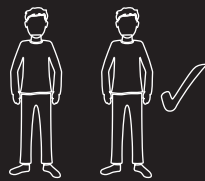

[01] x 1

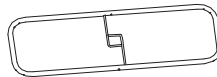

[02] x 1

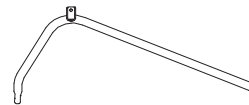

[03] x 4

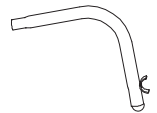

[04] x 2

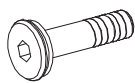

[05] x 8
(M6 x 35mm)

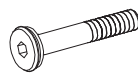

[06] x 2
(M6 x 55mm)



[07] x 10



[08] x 10



[09] x 20



[10] x 10

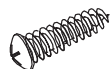

[11] x 2



[12] x 1



[13] x 1



[14] x 1

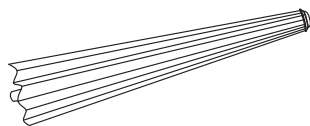

[15] x 1

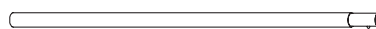

[16] x 1

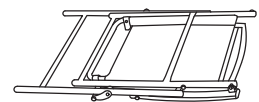

[17] x 6



EN Installation
 RO Instalare
 TR Kurulum

FR Installation
 ES Instalación

PL Instalacja
 PT Instalação

01

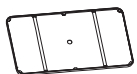

[01] x 1

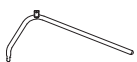

[03] x 4



[04] x 2

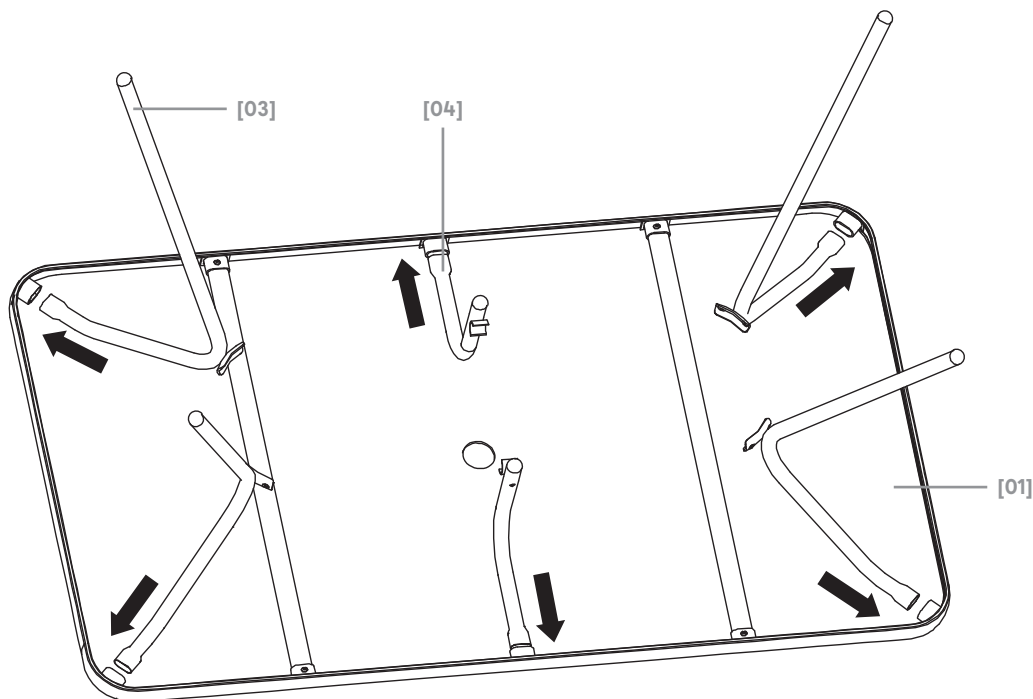

02



[02] x 1



[05] x 8



[06] x 2



[07] x 10



[08] x 10



[09] x 20



[10] x 10



[13] x 1



[14] x 1

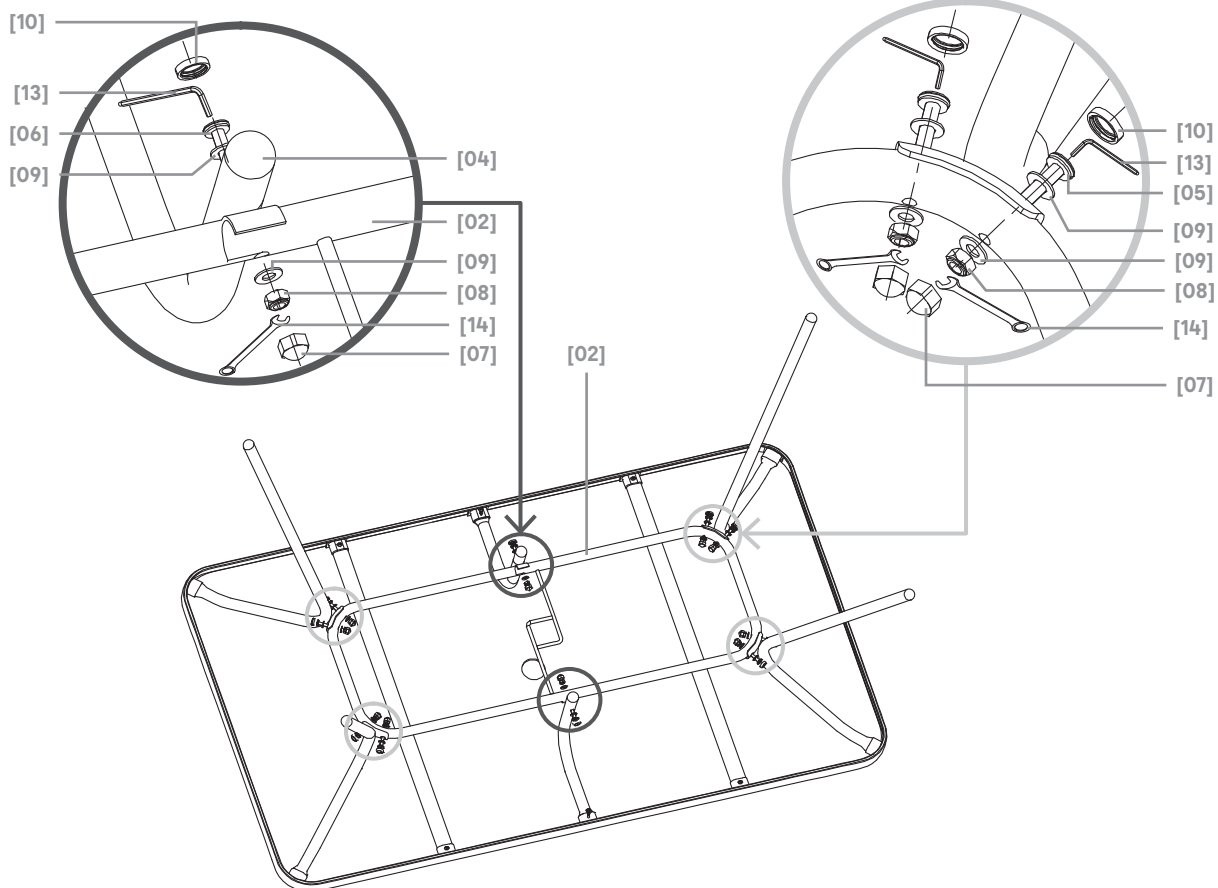



EN Installation
RO Instalare
TR Kurulum

FR Installation
ES Instalación

PL Instalacja
PT Instalação

5

03



[11] x 2

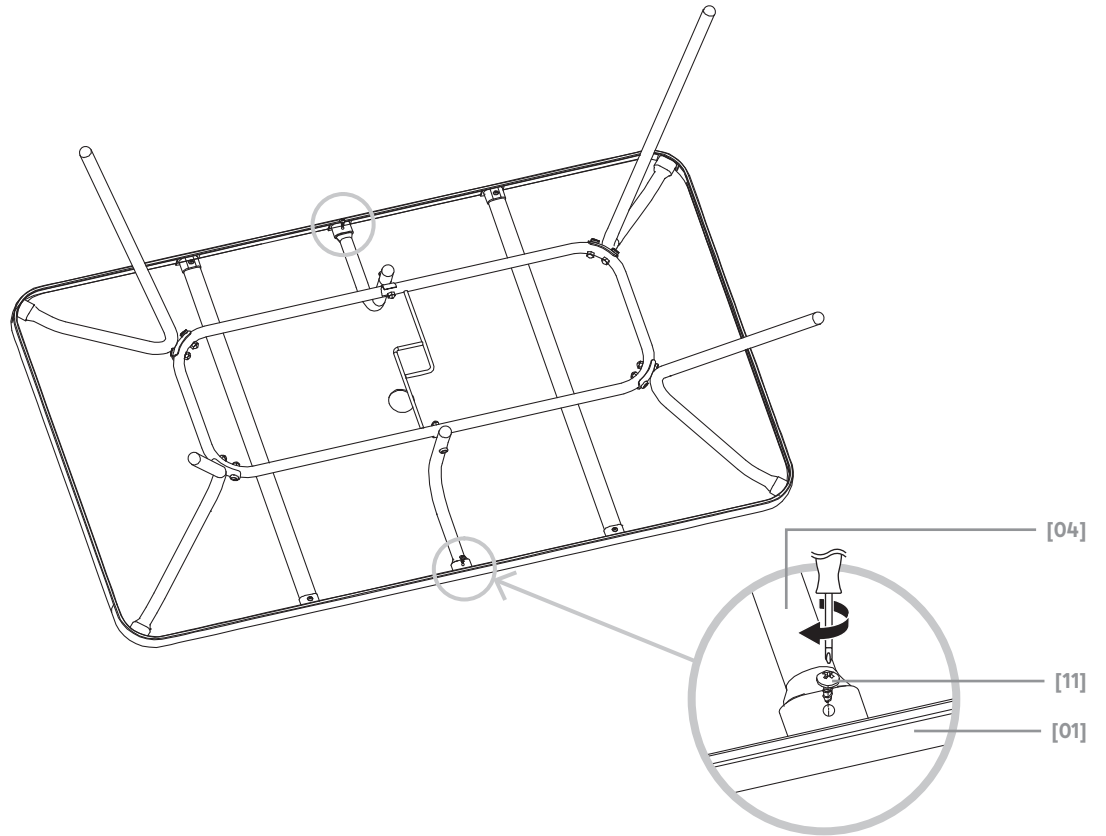

04



[12] x 1

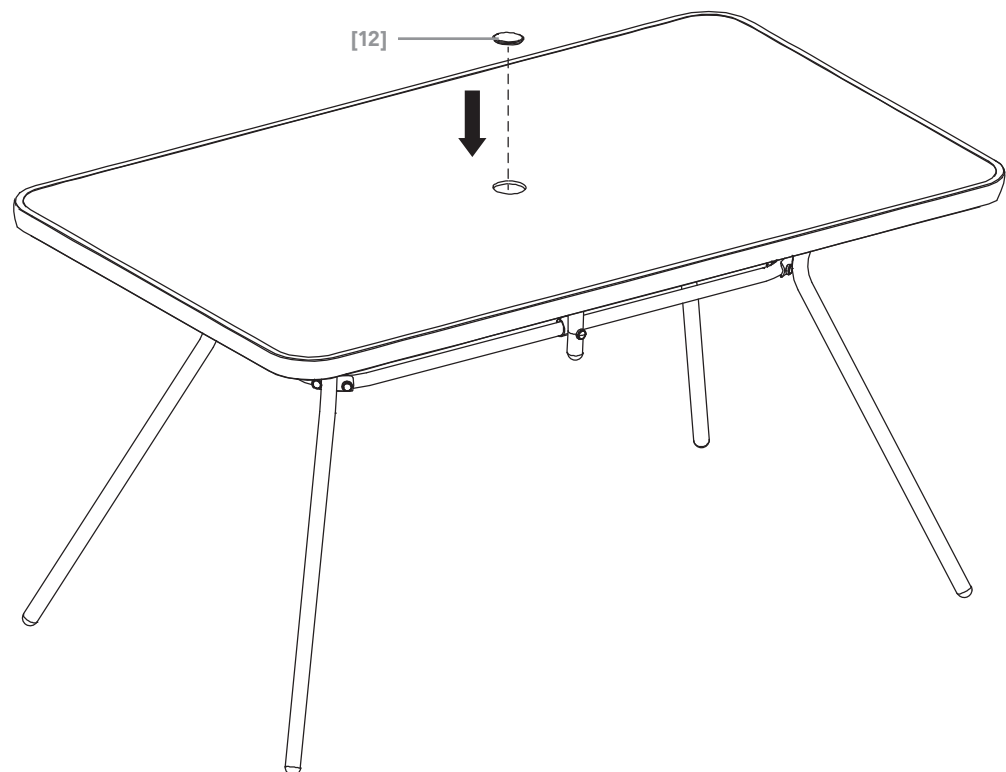



EN Installation
RO Instalare
TR Kurulum

FR Installation
ES Instalación

PL Instalacja
PT Instalação

6

05

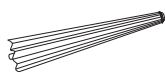

[15] x 1



[16] x 1

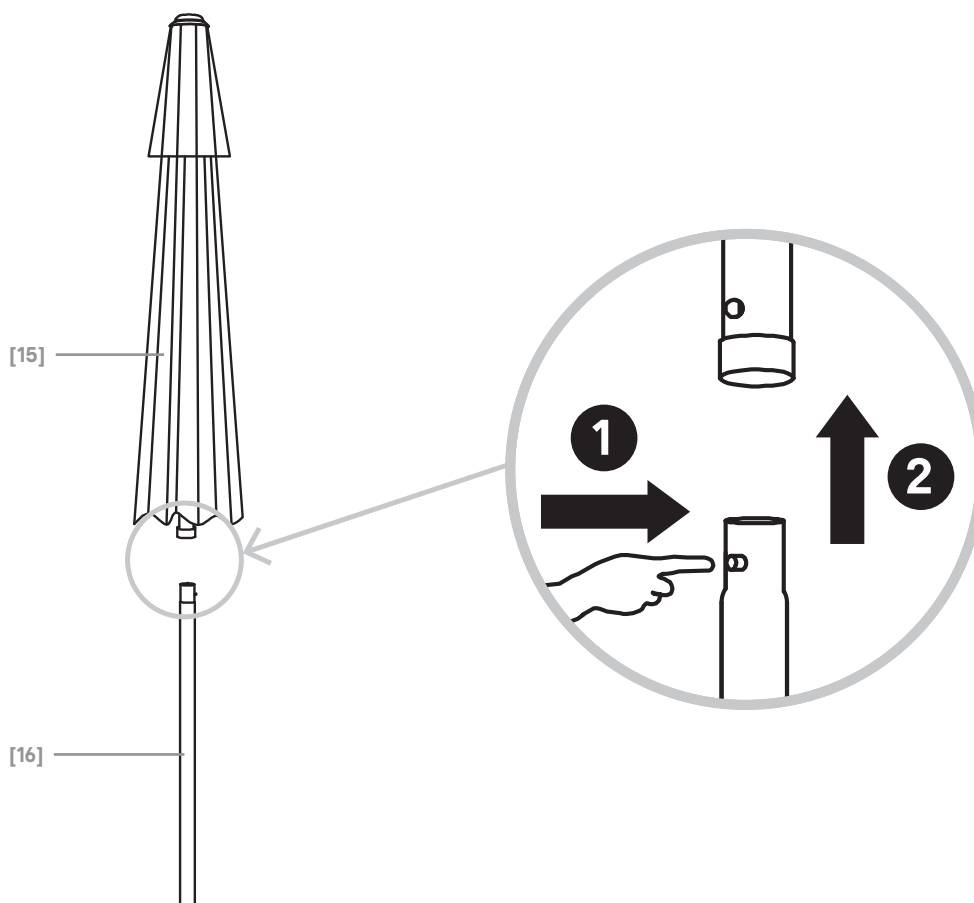

06

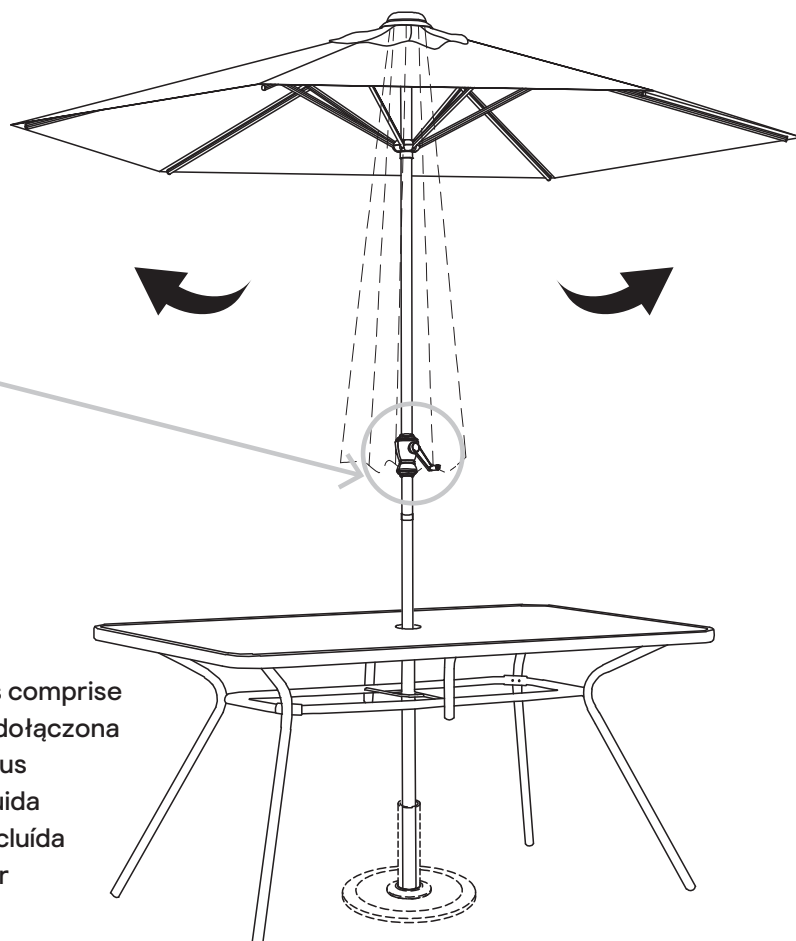
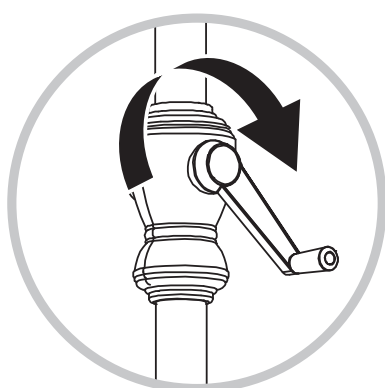

EN Parasol base not included
FR La base du parasol n'est pas comprise
PL Podstawa parasola nie jest dołączona
RO Bază de parasol nu este inclus
ES Base de la sombrilla no incluida
PT Base de parasol não está incluída
TR Şemsiye tabanı dahil değildir



EN Installation
RO Instalare
TR Kurulum

FR Installation
ES Instalación

PL Instalacja
PT Instalação

07

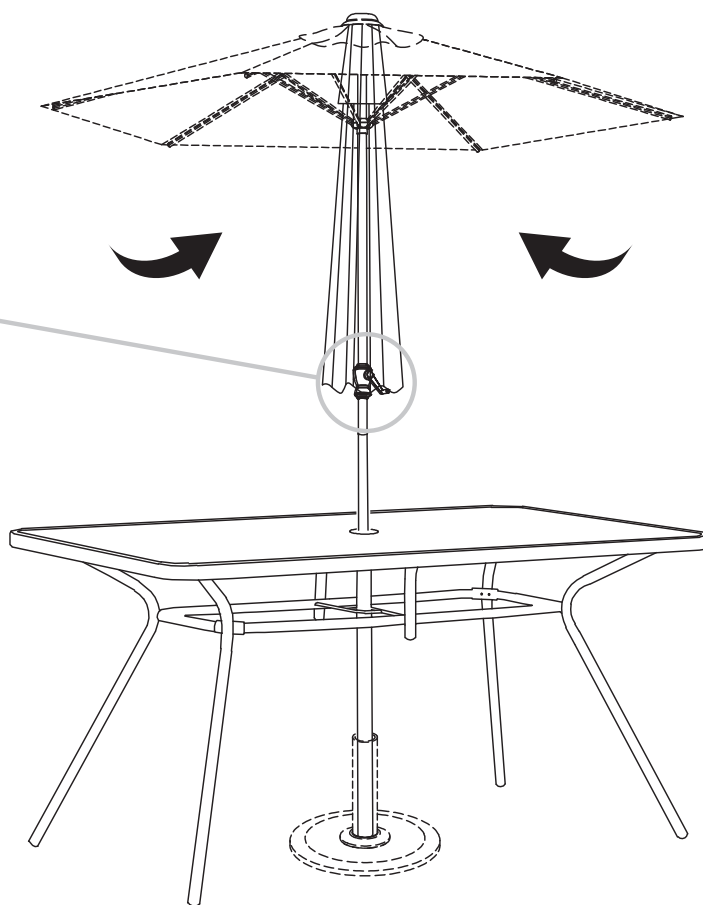
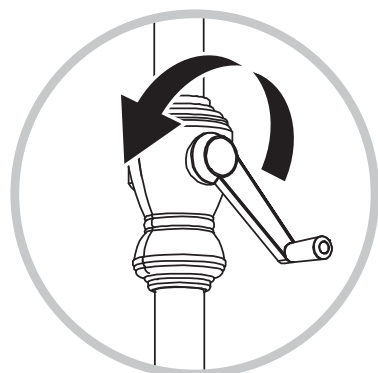

08

x 6

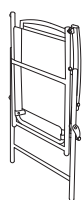

[17] x 6

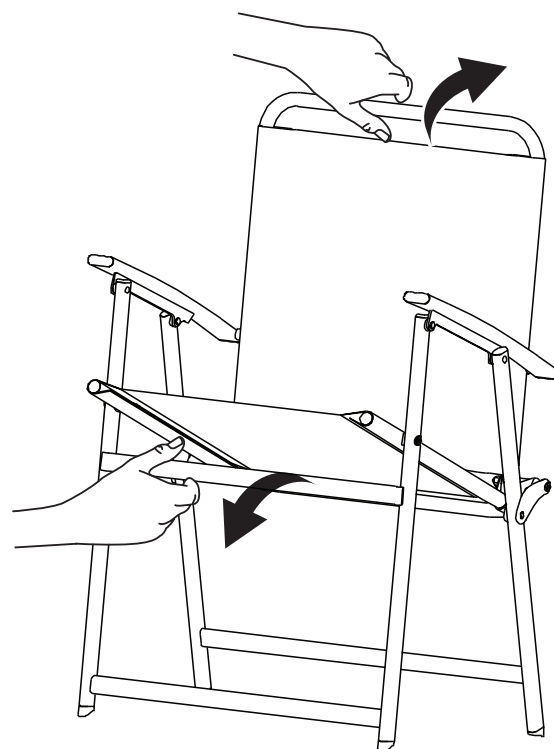
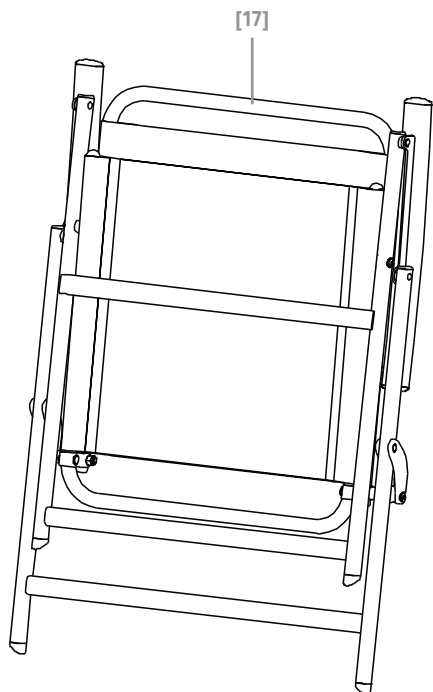



EN Installation
RO Instalare
TR Kurulum

FR Installation
ES Instalación

PL Instalacja
PT Instalação

09

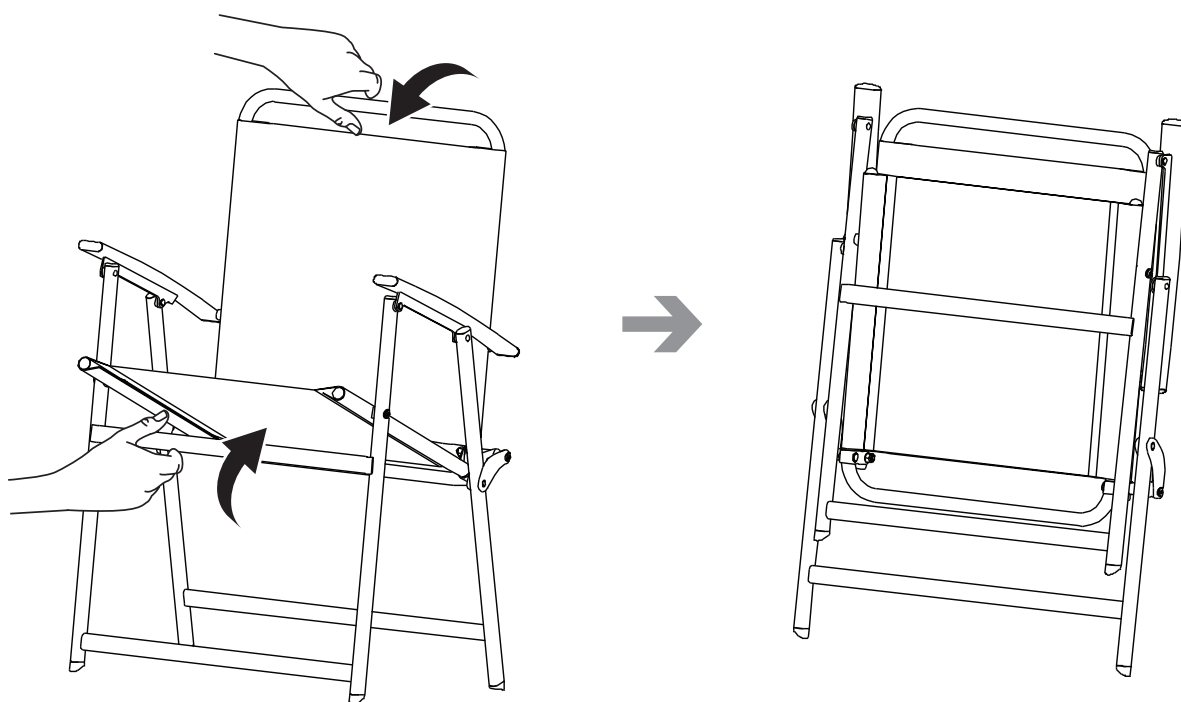

EN Care
RO Îngrijire
TR Bakım

FR Entretien
ES Cuidados

PL Czyszczenie
PT Cuidados

