

COOKE™
& LEWIS

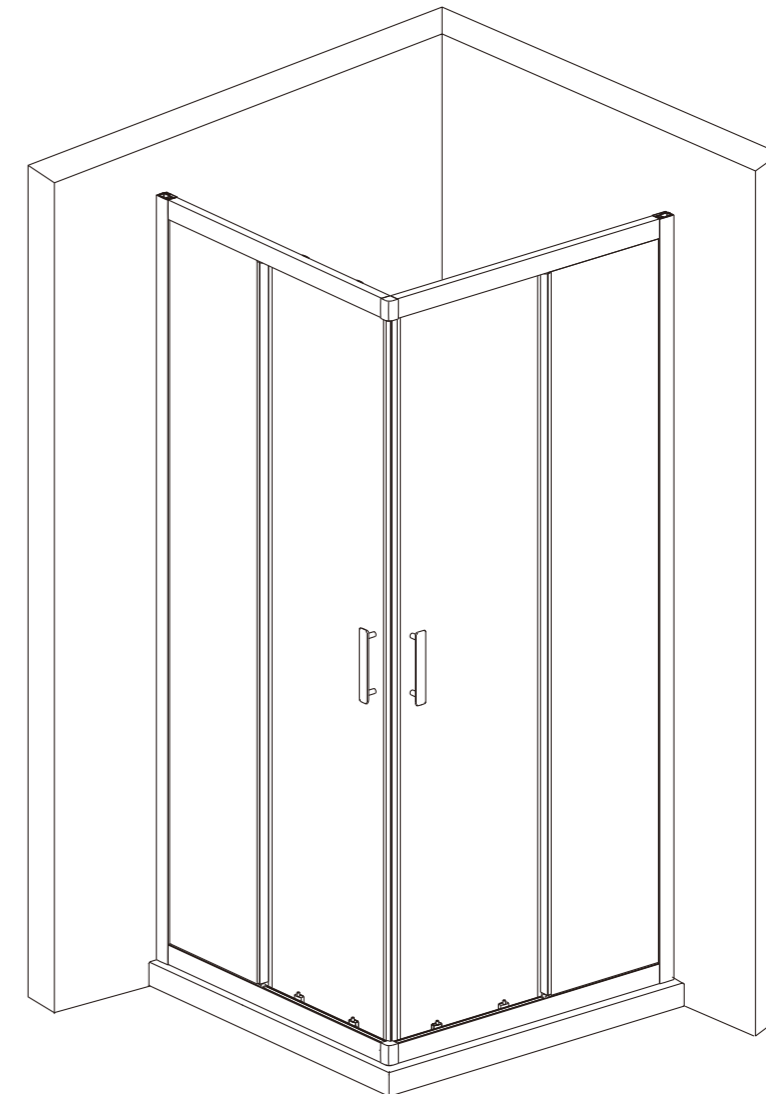

3663602944560 / 3663602944577 / 3663602944584 / 3663602944591 /
3663602944607 / 3663602944614 / 3663602944621 / 3663602944638 /
3663602944645 / 3663602944652 / 3663602944669 / 3663602944676 /
3663602944683 / 3663602944690 / 3663602944706 / 3663602944713 /

Beloya

Manufacturer, Fabricant, Producent, Hersteller,
Prodicator, Fabricante:
Kingfisher International Products Limited,
3 Sheldon Square, London, W2 6PX, United Kingdom



EN IMPORTANT - Please read carefully the separate safety guide before use.

FR IMPORTANT - Lire attentivement le guide de sécurité séparé avant utilisation.

PL WAŻNE - Przed użyciem proszę dokładnie zapoznać się z instrukcją bezpieczeństwa.

DE WICHTIG - Bitte lesen sie die separaten sicherheitsanweisungen vor gebrauch.

RUS ВАЖНО - Пожалуйста, внимательно прочитайте отдельное руководство по технике безопасности перед использованием.

RO IMPORTANT - Vă rugăm să citiți cu atenție ghidul de siguranță separat înainte de utilizare.

ES IMPORTANTE - Lea atentamente la guía de seguridad separado antes de utilizar.

PT IMPORTANTE - Leia atentamente o guia de segurança separado antes de usar.

TR ÖNEMLİ - Kullanmadan önce emniyet kurallarını lütfen dikkatle okuyun.

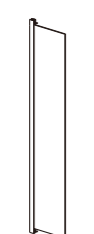
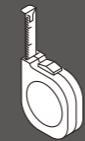
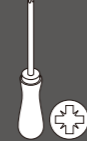
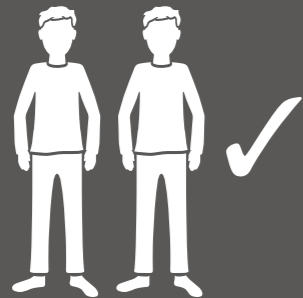

[01a] x 1

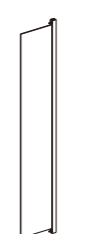

[01b] x 1

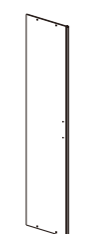

[02a] x 1

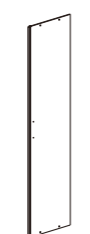

[02b] x 1

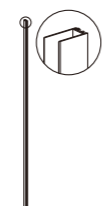

[03] x 2

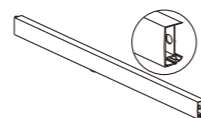

[04a] x 1

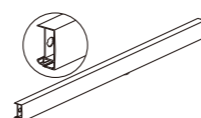

[04b] x 1

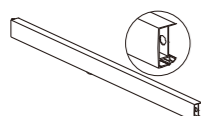

[05a] x 1

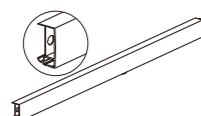

[05b] x 1



[06] x 2



[07] x 2

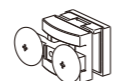

[08] x 4

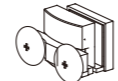

[09] x 4

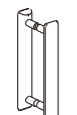

[10] x 2



[11] x 2



[12] x 2



[13] x 8



[14] x 8



[15] x 4



[16] x 4

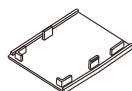

[17] x 1

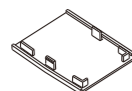

[18] x 1

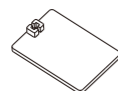

[19] x 2



[20] x 8 (ST4 x 12mm)



[21] x 8 (ST4 x 30mm)

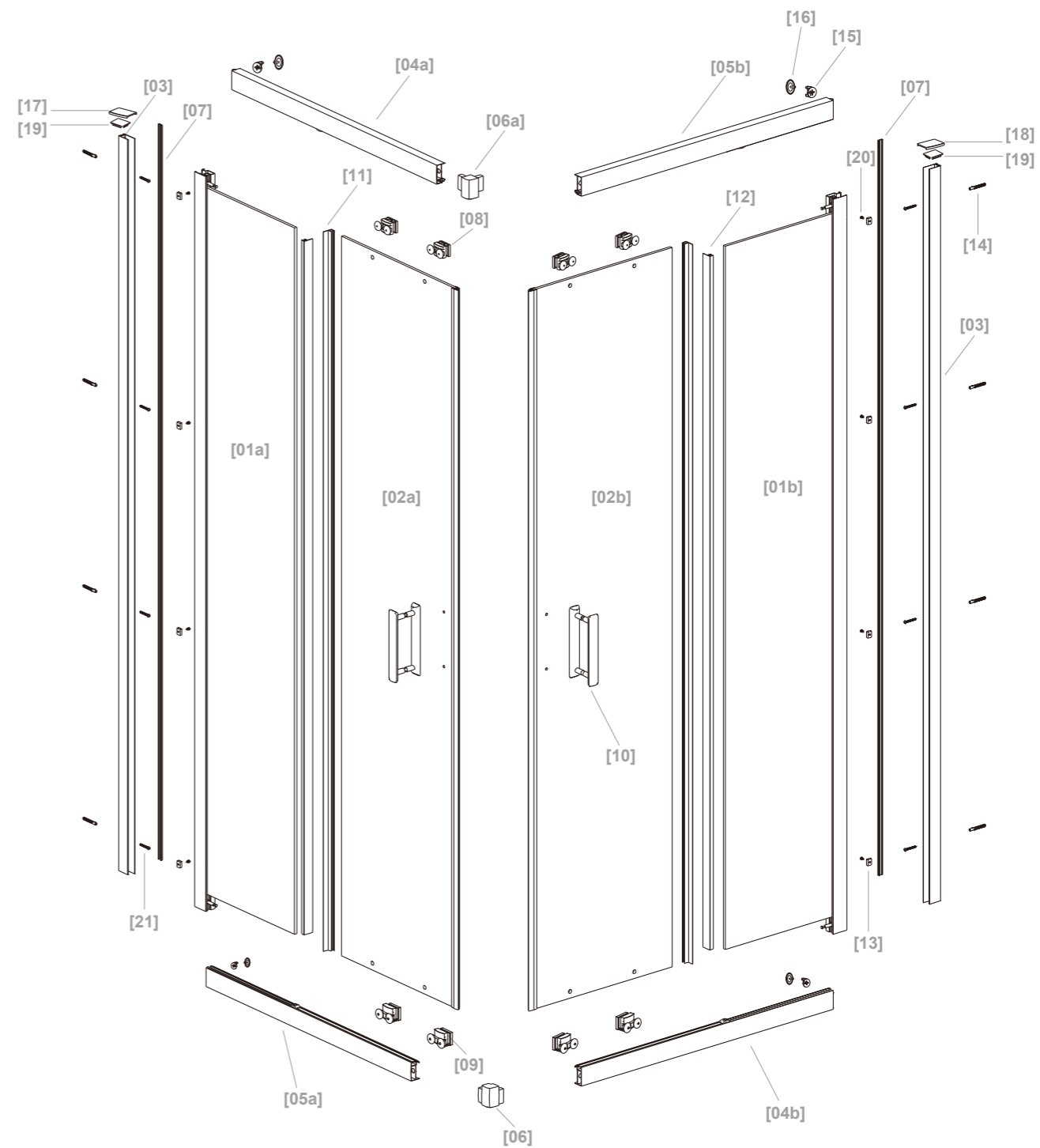



01



[01a] x 1



[01b] x 1

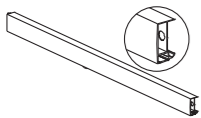

[04a] x 1

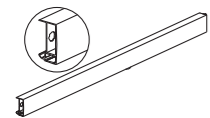

[04b] x 1

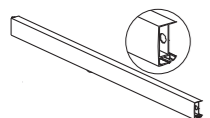

[05a] x 1

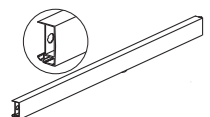

[05b] x 1



EN Note: Ensure that the sides of the glass panels with the Easy Clean treatment logo on are positioned facing inward.
FR Remarque : Assurez-vous que les faces des panneaux en verre avec le logo nettoyage facile sont positionnées face vers l'intérieur.
PL Informacja: Upewnij się, że obie strony szyb pokrytych powłoką "Easy Clean" są skierowane do wewnątrz.
DE Hinweis: Vergewissern Sie sich, dass die Seiten der Glasscheiben mit der Easy Clean-Behandlung an der Wandseite nach innen zeigen.
RU Примечание. Убедитесь, что стороны стеклянных панелей со специальной обработкой для легкой очистки ориентированы внутрь.
RO Notă: Asigurați-vă că panourile de sticlă cu fațada tratată cu Easy Clean sunt poziționate înspre interiorul cabinei.
ES Nota: Asegúrese que los lados de los paneles de vidrio con tratamiento de Easy Clean estén colocados hacia el interior.
PT Nota: Certifique-se de que os lados dos painéis de vidro com o tratamento Easy Clean estão voltados para dentro.
TR Not: Cam panellerin, üzerinde Kolay Temizlik uygulaması bulunan yüzeyinin içe doğru bakacak şekilde konumlanmış olduğundan emin olun.

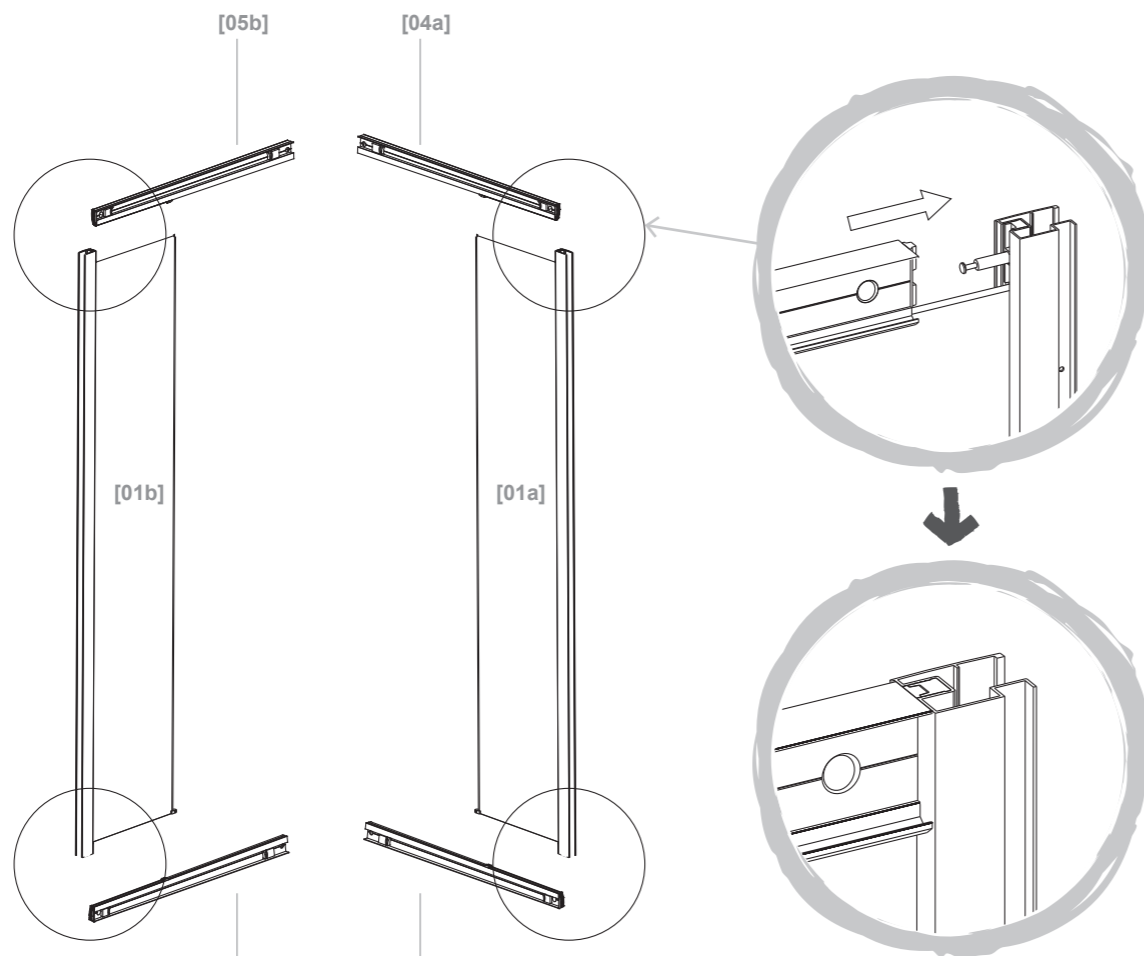

02



[15] x 4



[16] x 4

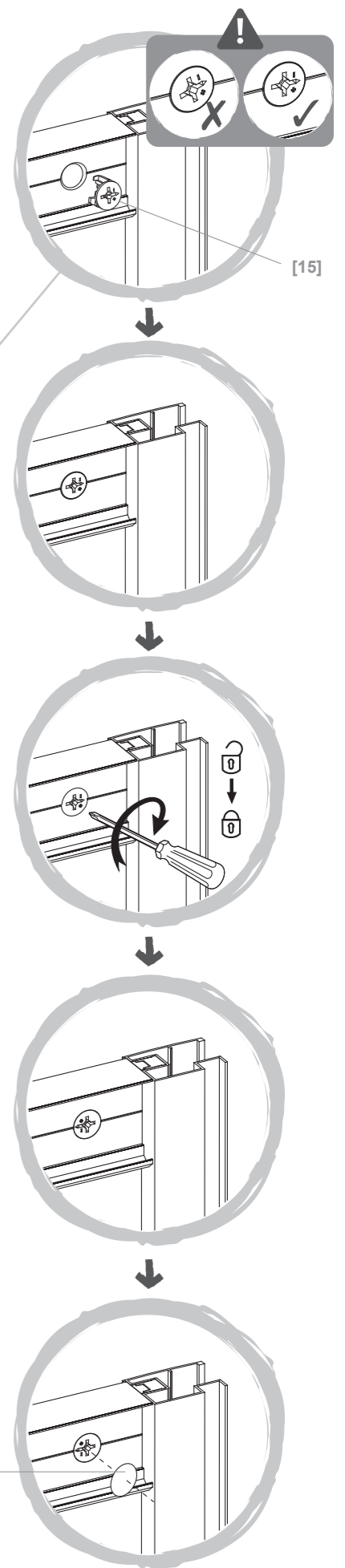
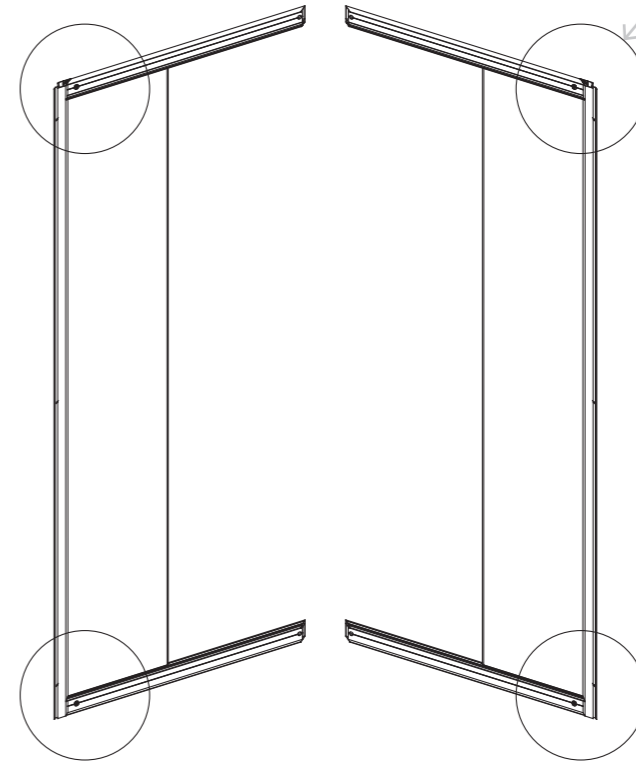

03



[06] x 2

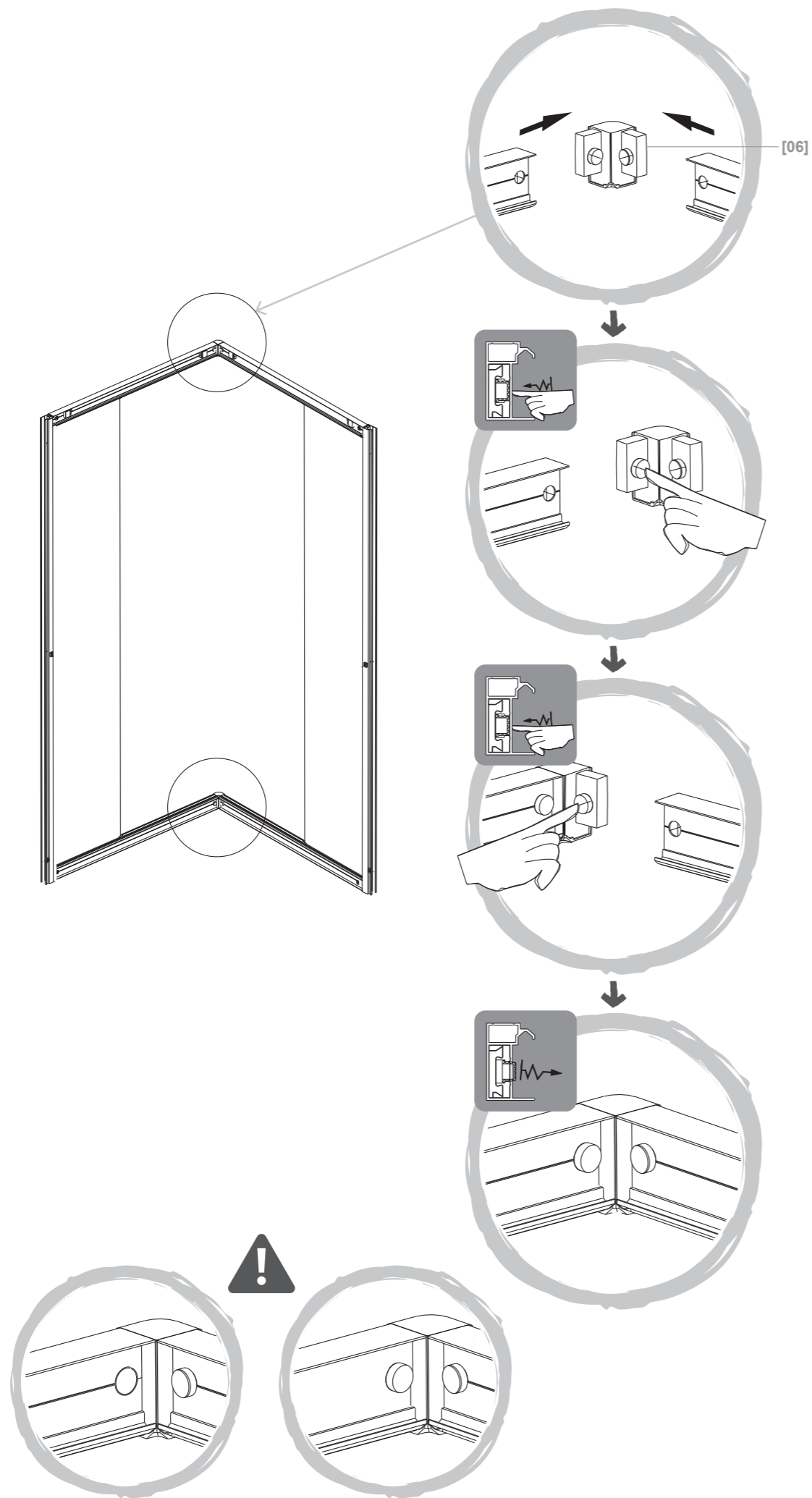

6

04



[03] x 2

Model	A(mm)	B(mm)
3663602944560/3663602944645	671-696	671-696
3663602944577/3663602944652	731-756	731-756
3663602944584/3663602944669	771-796	771-796
3663602944591/3663602944676	871-896	871-896
3663602944607/3663602944683	771-796	1171-1196
	1171-1196	771-796
3663602944614/3663602944690	671-696	871-896
	871-896	671-696
3663602944621/3663602944706	671-696	971-996
	971-996	671-696
3663602944638/3663602944713	671-696	1171-1196
	1171-1196	671-696

7

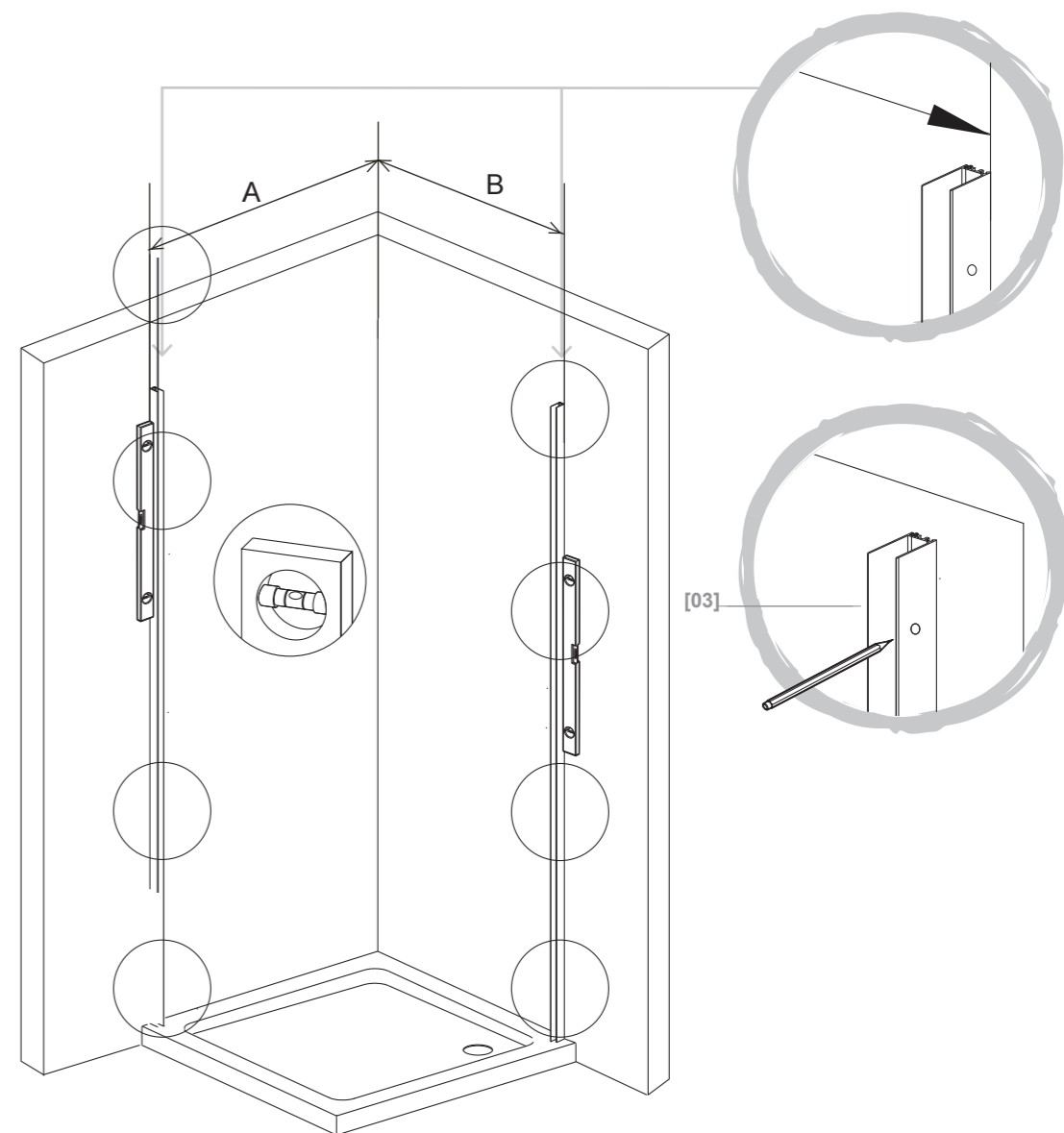

05



[14] x 8



[21] x 8
(ST4x30mm)

8

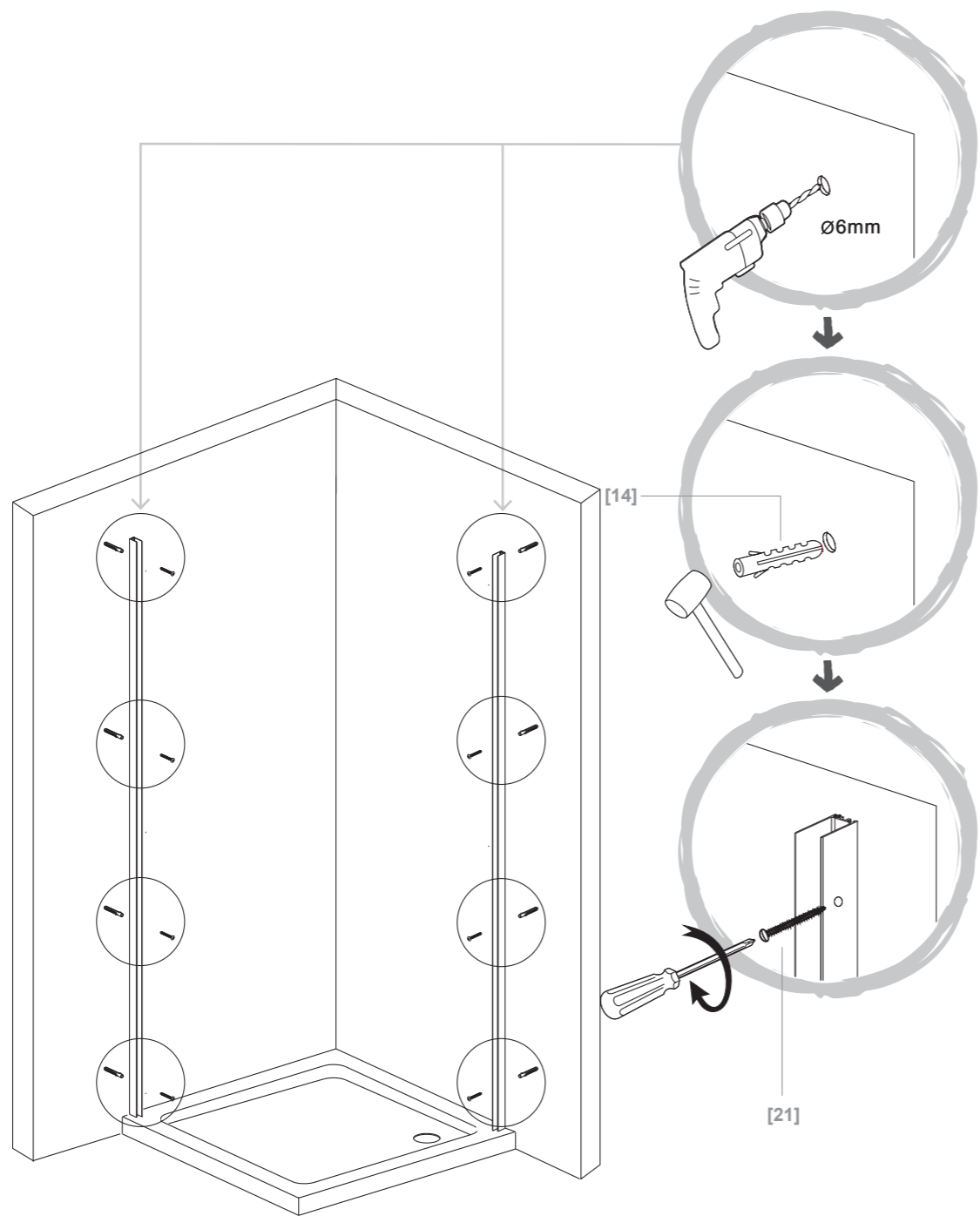

06

9

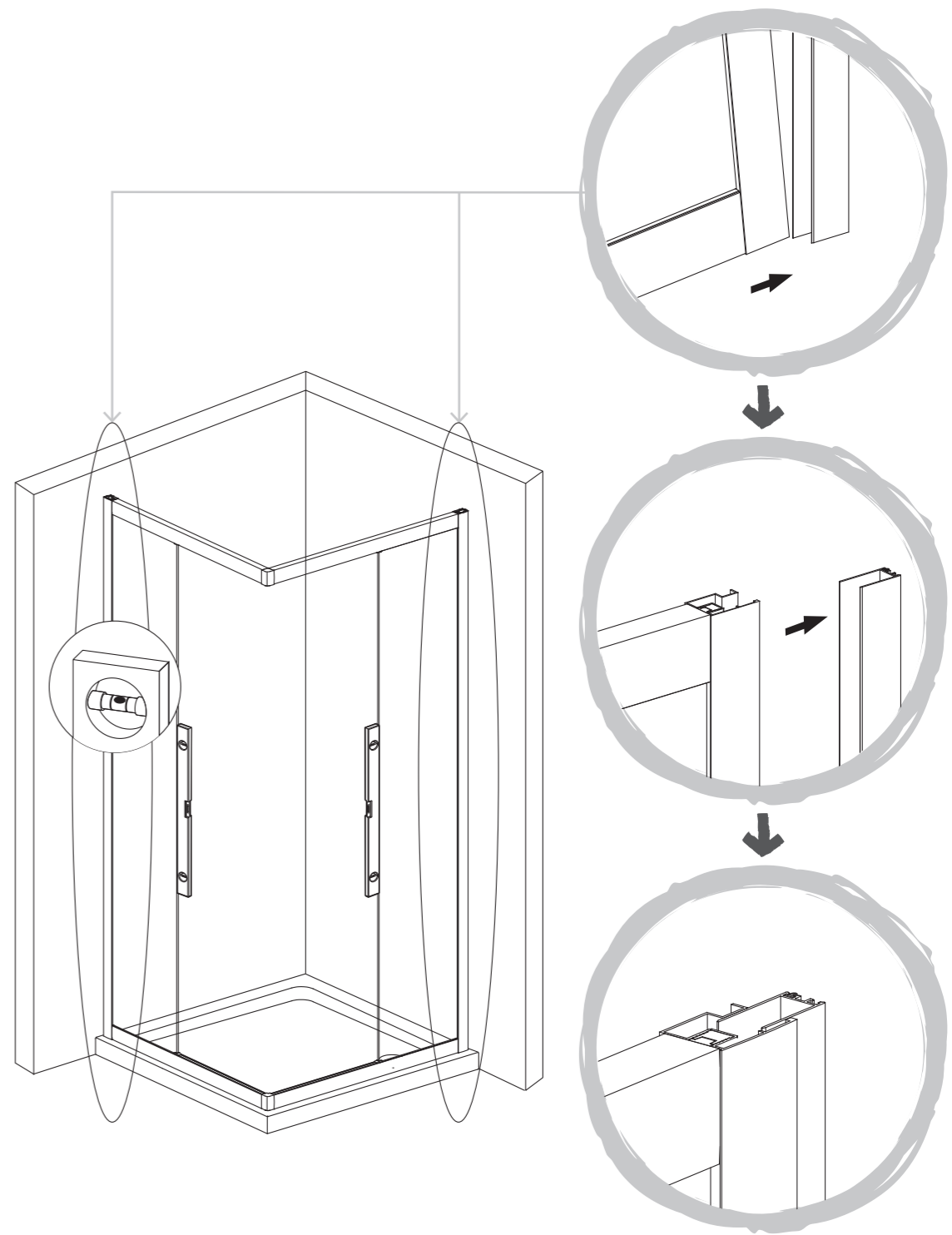

07

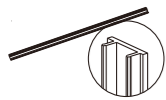

[07] x 2



[13] x 8



[20] x 8
(ST4x12mm)

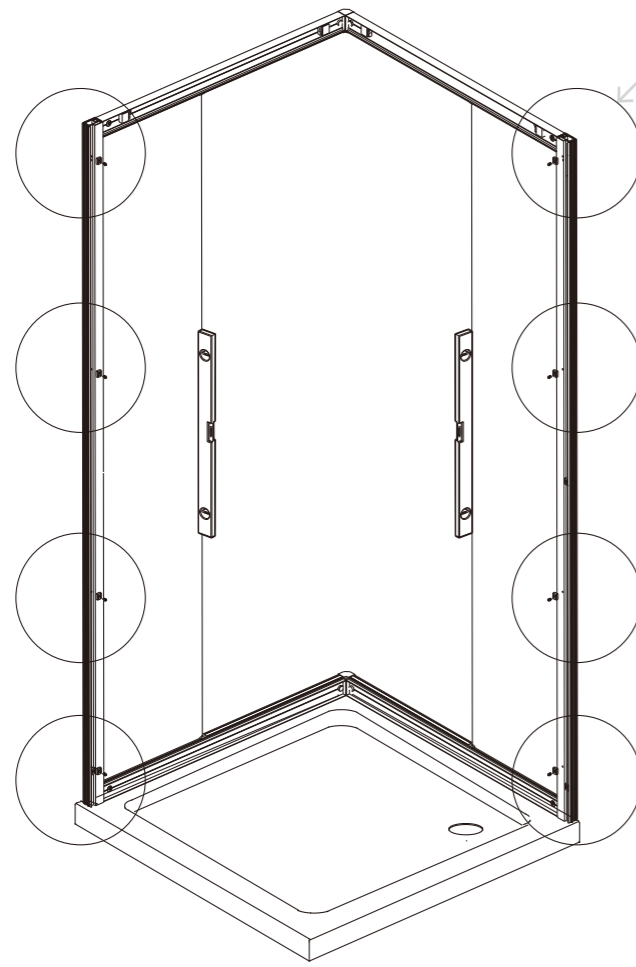

10

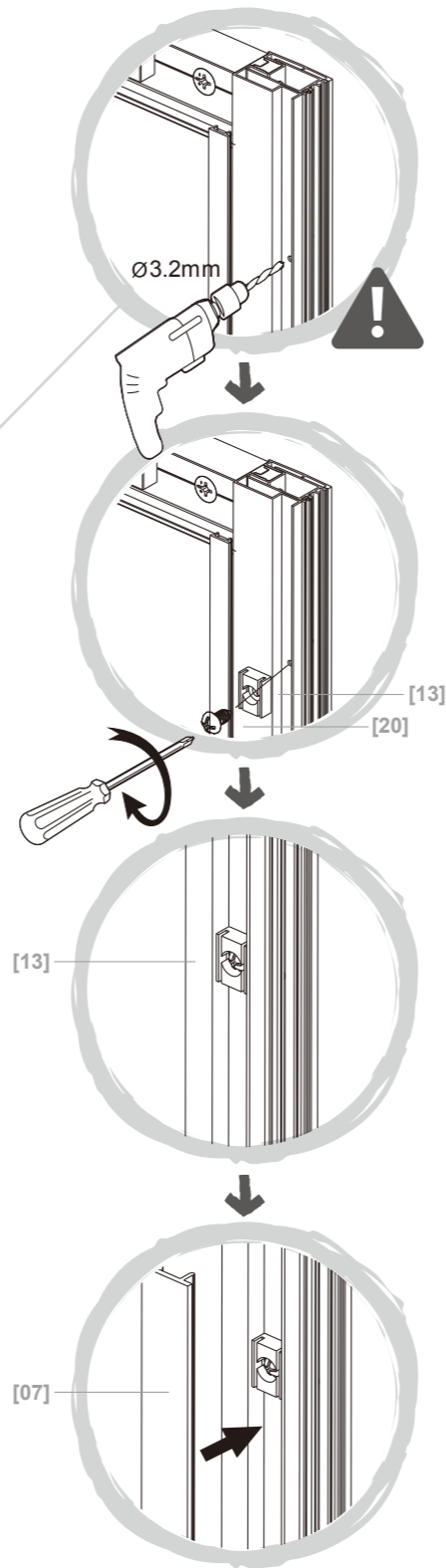

08



[02a] x 1



[02b] x 1

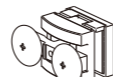

[08] x 4

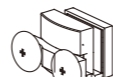

[09] x 4

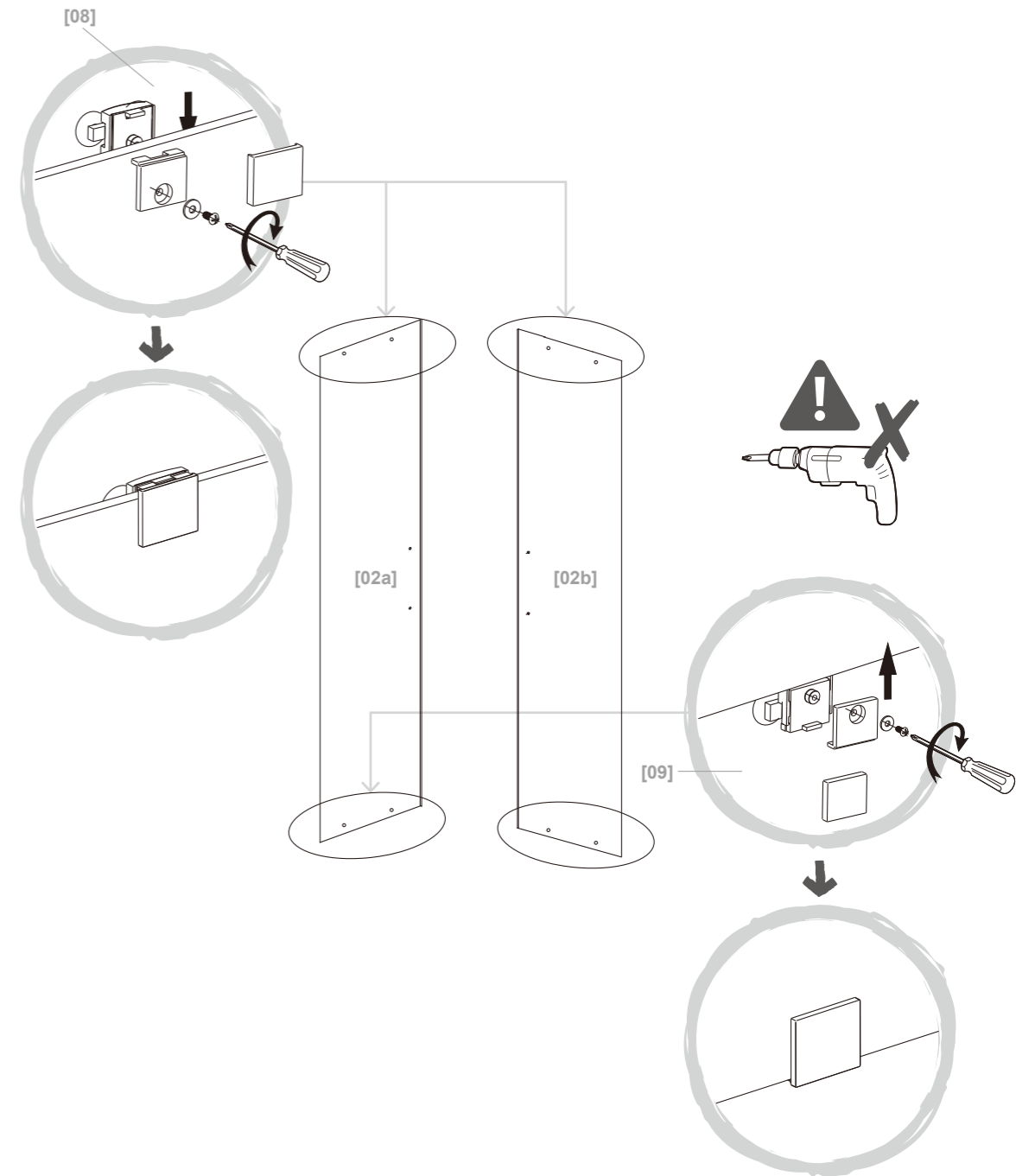

11

09



[10] x 2

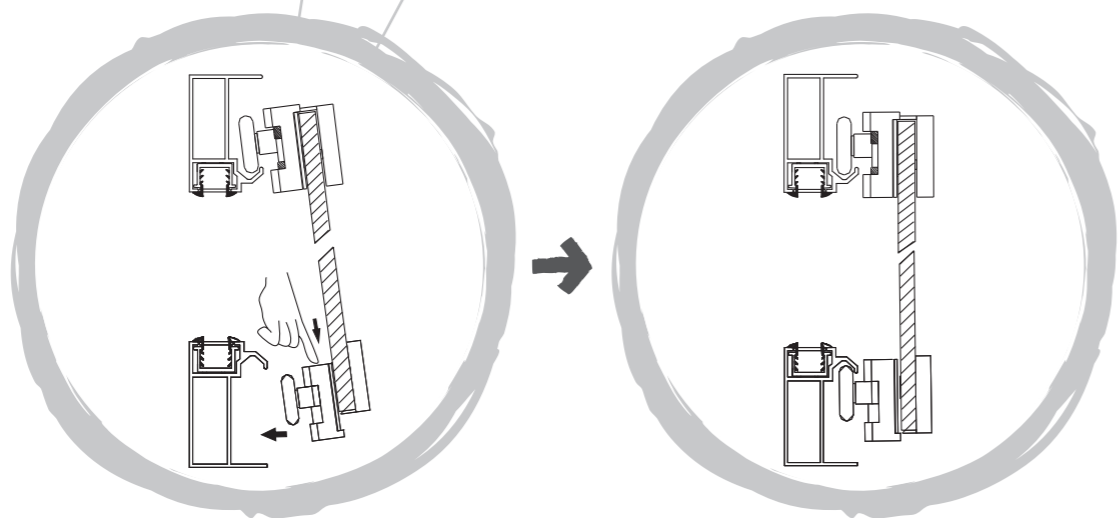
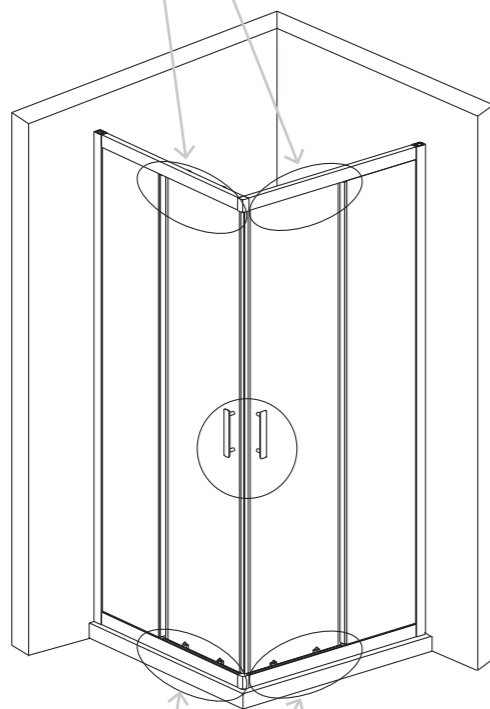
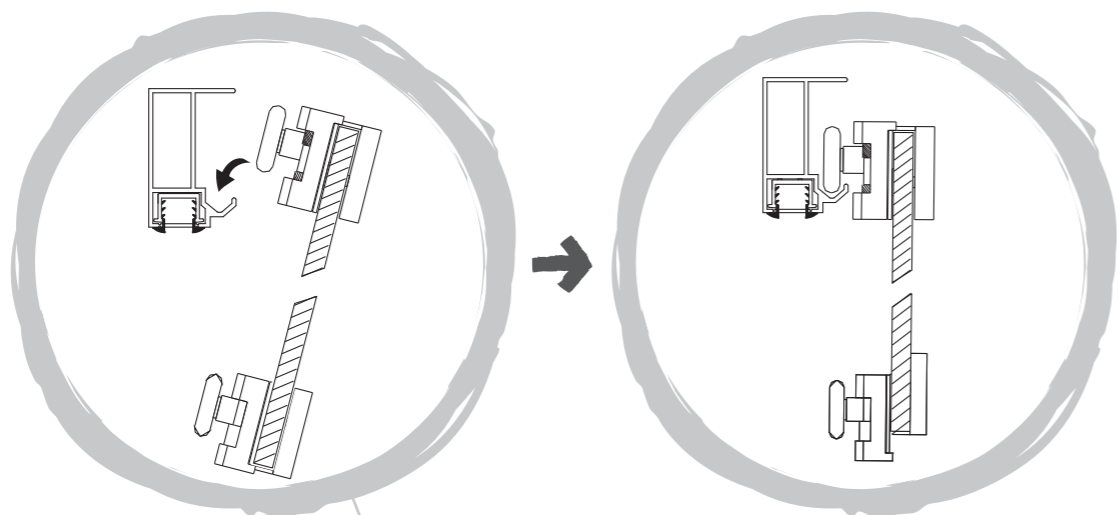

12

10



[11] x 2



[12] x 2

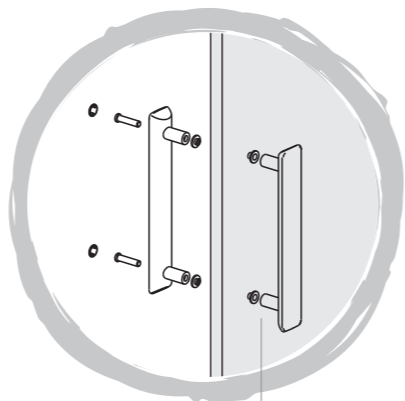

[10]

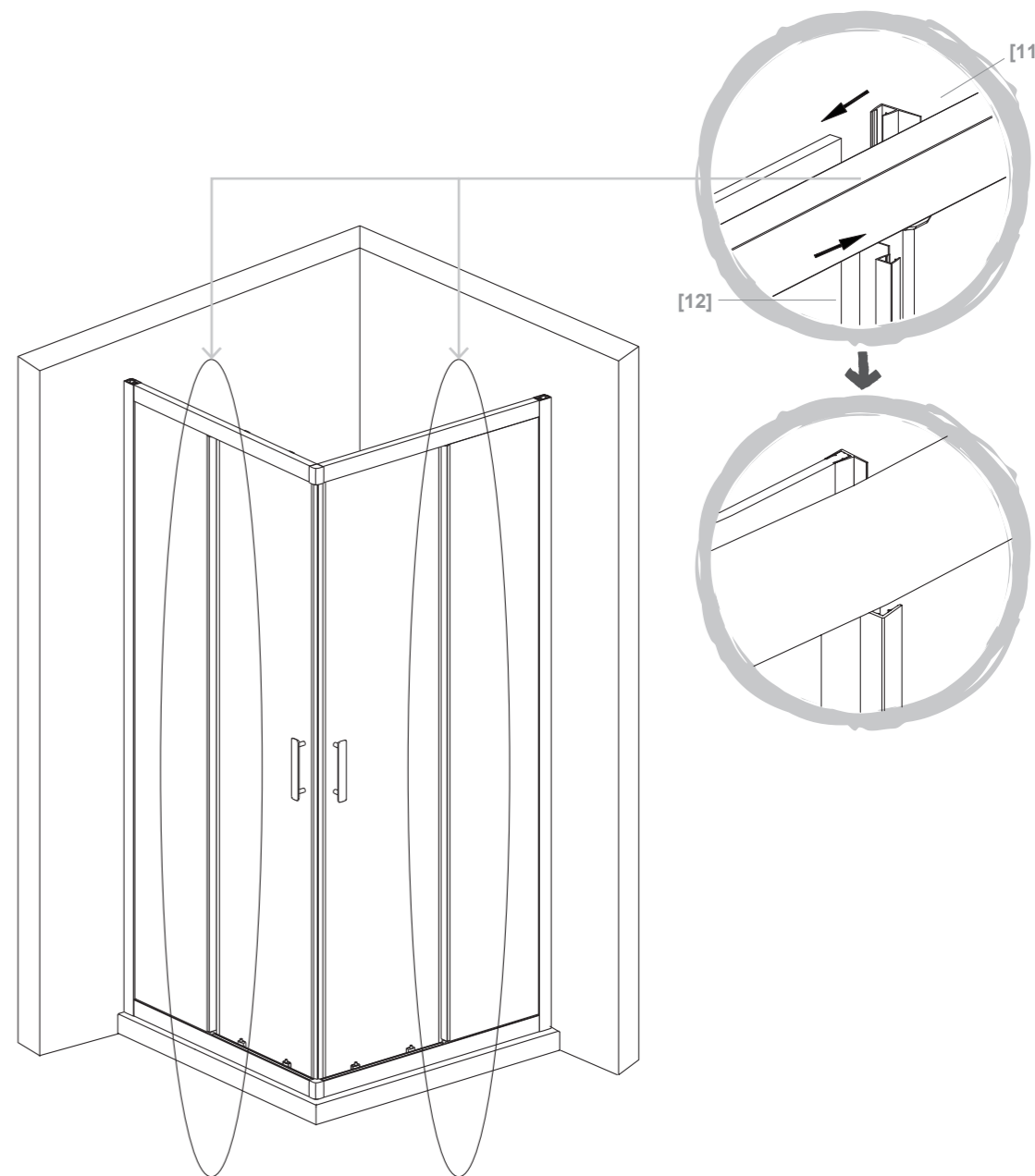

13

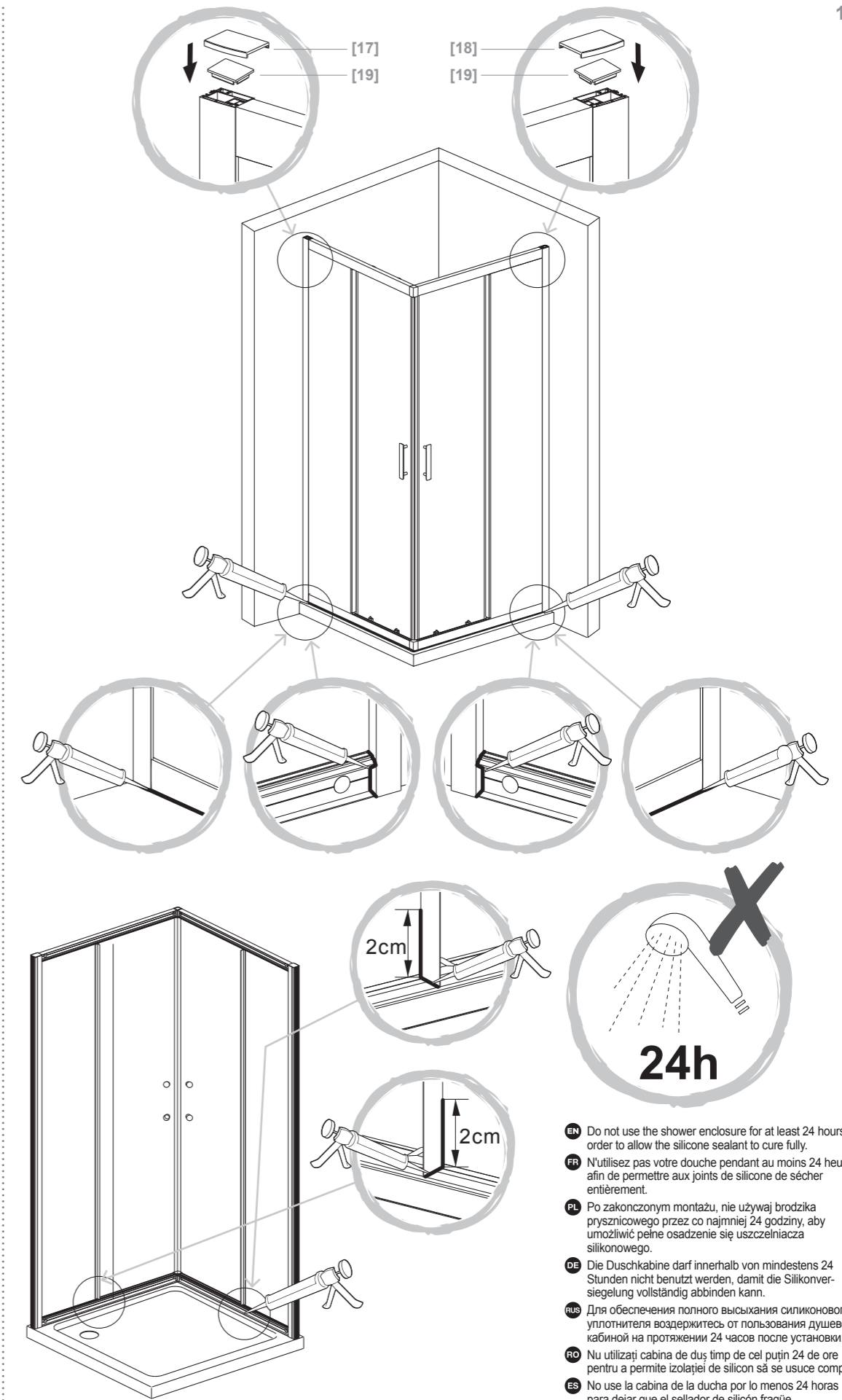
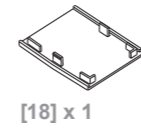
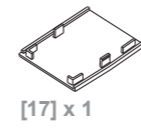
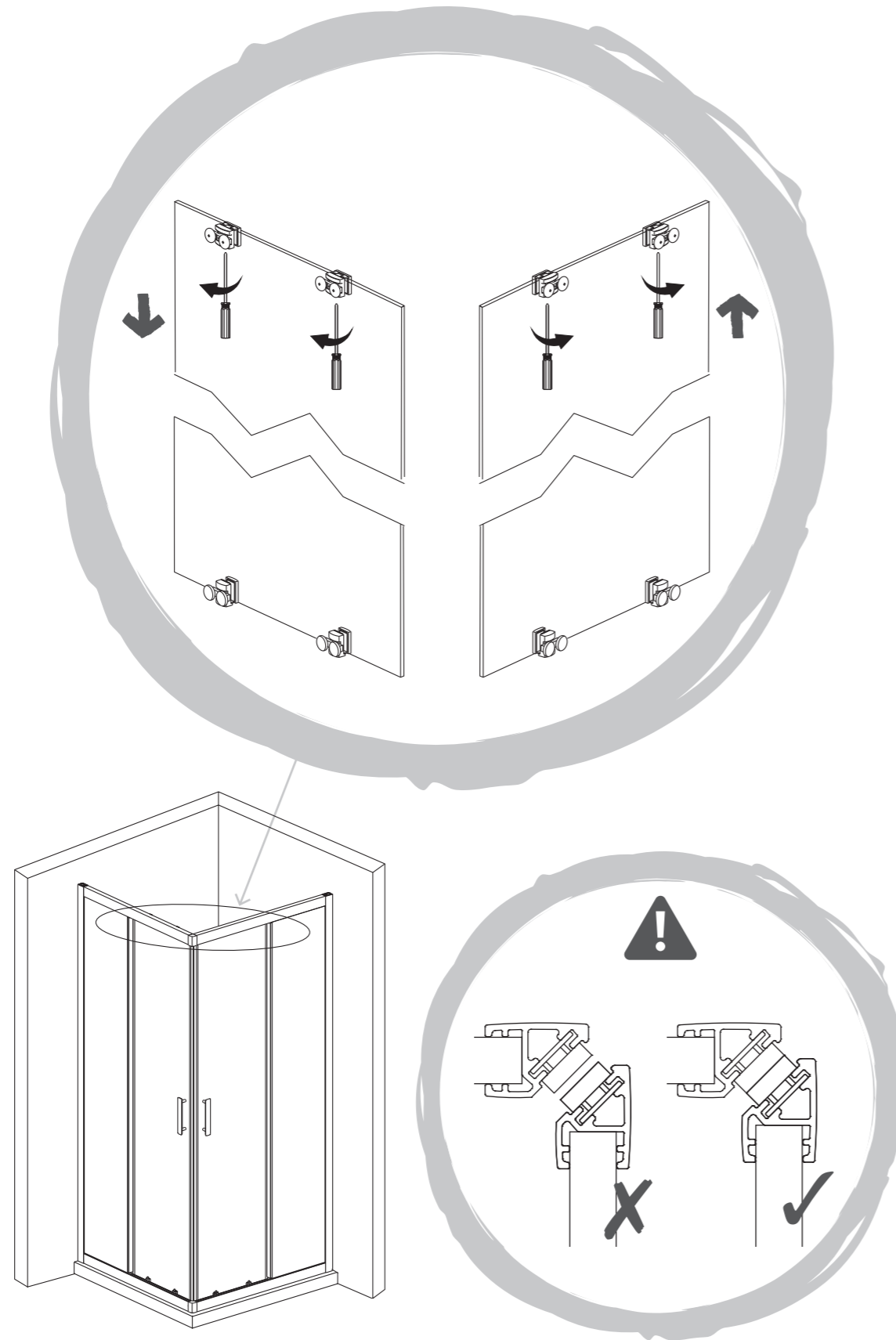

- EN** Do not use the shower enclosure for at least 24 hours in order to allow the silicone sealant to cure fully.
- FR** N'utilisez pas votre douche pendant au moins 24 heures afin de permettre aux joints de silicone de sécher entièrement.
- PL** Po zakończonym montażu, nie używaj brodzika prysznicowego przez co najmniej 24 godziny, aby umożliwić pełne osadzenie się uszczelnacza silikonowego.
- DE** Die Duschkabine darf innerhalb von mindestens 24 Stunden nicht benutzt werden, damit die Silikonversiegelung vollständig abbinden kann.
- RU** Для обеспечения полного высыхания силиконового уплотнителя воздержитесь от пользования душевой кабиной на протяжении 24 часов после установки.
- RO** Nu utilizați cabina de duș timp de cel puțin 24 de ore pentru a permite izolației de silicon să se usuce complet.
- ES** No use la cabina de la ducha por lo menos 24 horas para dejar que el sellador de silicon se seque completamente.
- PT** Não utilize a divisória de chuveiro durante, no mínimo, 24 horas para garantir que o vedante de silicone fica totalmente seco.
- TR** Silikon sızdırmazlık malzemesinin tamamen kurumasına izin vermek için duşakabinini en az 24 saat boyunca kullanmayın.

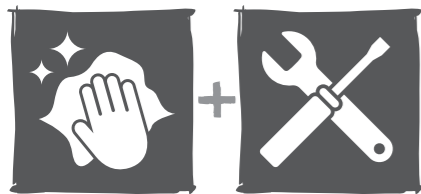

EN Care & maintenance
PL Pielęgnacja i konserwacja
RUS Уход и обслуживание
ES Cuidados y Mantenimiento
TR Bakım ve Onarım

FR Entretien et maintenance
DE Pflege und Wartung
RO Îngrijire și întreținere
PT Cuidados e manutenção

16

EN

The golden rules for care

NOTE: Use warm soapy water and a soft damp cloth to keep the glass clean. Wipe dry with a clean cloth. Glass cleaner can be used if required. Scourers, abrasives and chemical cleaners can damage the glass and pattern, and should not be used.

In hard water areas, insoluble lime salts may be deposited on the glass. If this is allowed to build up it becomes increasingly difficult to remove and looks unsightly. Regular cleaning will minimize this effect.

- Do not attempt to cut the glass.
- Do not strike the glass with hard or pointed items.
- Regularly check moving parts such as rollers and hinges to ensure they are secure and adjusted correctly. Tighten and adjust where required. Also check all sealed joints to ensure seal has not deteriorated. Re-seal if required.

FR

Les règles d'or pour l'entretien

REMARQUE : Utilisez de l'eau tiède savonneuse et un chiffon doux humide pour garder la vitre propre. Essuyez à l'aide d'un chiffon propre. Si nécessaire, vous pouvez utiliser un produit pour vitres. Grattoirs, abrasifs et nettoyeurs chimiques peuvent endommager la vitre et le motif, et ne doivent ainsi pas être utilisés.

Dans les zones dont l'eau est dure, un dépôt de calcaire peut se former sur la vitre. Si vous le laissez s'accumuler, il deviendra de plus en plus difficile à enlever, et sera inesthétique. Un nettoyage régulier permet de réduire cet effet.

- Ne tentez pas de découper la vitre.
- Ne cognez pas la vitre avec des objets durs ou pointus.
- Vérifiez régulièrement les pièces mobiles telles que les rouleaux et charnières afin de vous assurer qu'elles sont solidement fixées et correctement réglées. Serrez et ajustez-les lorsque nécessaire. Vérifiez également tous les joints scellés afin de vous assurer de l'intégrité de l'étanchéité. Scellez à nouveau au besoin.

PL

Zasady bezpiecznego użytkowania

INFORMACJA: Użyj szmatki z ciepłą mydlaną wodą do czyszczenia szyb. W razie konieczności, można użyć płynu do mycia szyb. Nie należy używać do czyszczenia ostrych zmywaków oraz szorujących lub chemicznych środków czyszczących, ponieważ mogą one uszkodzić szklaną powierzchnię lub wzór na szkle.

W twardej wodzie, nierozpuszczalne sole wapna mogą odkładać się na szybie. Jeśli nagromadzi się ich duża ilość, wówczas stają się one bardzo trudne do usunięcia. Regularne czyszczenie zminimalizuje ten efekt.

- Nie przecinaj szyb.
- Nie uderzaj w szyby twardymi lub spiczastymi przedmiotami.
- Regularnie sprawdzaj ruchome części, takie jak rolki i zawiasy, aby upewnić się, że są one bezpieczne i właściwie ustawione. Dokręć i wyreguluj je w razie potrzeby. Dodatkowo sprawdzaj wszystkie uszczelnione złącza, aby upewnić się, że uszczelnienie nie uległo pogorszeniu. Ponownie uszczelnij w razie potrzeby.

DE

Die goldenen Regeln der Pflege

HINWEIS: Zum Reinigen des Glases warme Seifenlauge und einen weichen, feuchten Lappen benutzen. Mit einem trockenen Lappen trockenwischen. Bei Bedarf kann Glasreiniger verwendet werden. Scheuerschwämme, Scheuermittel und chemische Reiniger können das Glas und die Musterung angreifen und sollten daher nicht benutzt werden.

In Gebieten mit hartem Wasser können sich Kalkablagerungen am Glas bilden. Wenn diese nicht beseitigt werden und sich immer weiter Kalk ablagert, wird es umso schwieriger, die Kalkreste zu entfernen. Nach einiger Zeit wirken diese verkalkten Stellen unansehnlich. Durch regelmäßiges Reinigen kann dem vorgebeugt werden.

- Nicht das Glas anschneiden.
- Nicht mit harten oder spitzen Gegenständen gegen das Glas stoßen.
- Bewegliche Teile wie Rollen und Scharniere regelmäßig auf festen Sitz und richtige Justage überprüfen. Ggf. nachstellen und nachziehen. Außerdem alle versiegelten Übergänge prüfen, um festzustellen, ob die Dichtungen noch intakt sind. Ggf. nachdichten.

RUS

золотых правила для постоянного использования

ПРИМЕЧАНИЕ. Для очистки стекла используйте воду с мылом и мягкую влажную тряпку. Вытрите насухо чистой тряпкой. При необходимости можно использовать средство для очистки стекла. Не используйте металлические мочалки, абразивные материалы и химические чистящие средства, поскольку они могут повредить стекло и орнамент.

В регионах с жесткой водой на стекле может скапливаться нерастворимый известковый налет. Со временем налет затвердевает и приобретает неприятный вид. Регулярная очистка поможет избежать этого явления.

- Не пытайтесь резать стекло.
- Не ударяйте по стеклу твердыми или острыми предметами.
- Регулярно проверяйте движущиеся детали, чтобы убедиться, что они зафиксированы и правильно отрегулированы. Если необходимо – зафиксируйте и отрегулируйте. Также проверяйте все уплотненные соединения, чтобы убедиться в том, что уплотнение не повреждено. При необходимости уплотните повторно.

17

Cele reguli de aur pentru întreținere

NOTĂ: Utilizați apă caldă cu detergent și o cârpă moale pentru a menține geamul curat. Uscați ștergând cu o cârpă curată. Dacă este nevoie, puteți utiliza produs de curățat geamuri. Bureții abrazivi, produsele de curățat abrazive și chimice pot avaria sticla și aspectul acesteia, și nu ar trebui utilizate.

În zone cu apă dură, săruri insolubile de calcar se pot acumula pe sticlă. Dacă acestea sunt lăsate să se depoziteze, aceste acumulări pot deveni extrem de greu de îndepărtat și vor arăta neaspectuos. Curățarea periodică va minimiza acest efect.

- Nu încercați să tăiați sticla.
- Nu loviți sticla cu articole ascuțite sau dure.
- Verificați periodic piesele mobile precum roțile și balamalele pentru a vă asigura că sunt sigure și reglate corect. Strângeți și ajustați unde este nevoie. De asemenea verificați toate izolațiile de etanșizare pentru a vă asigura că nu sunt deteriorate. Reizolați dacă este nevoie.

Las reglas de oro para su uso y mantenimiento

NOTA: Use agua jabonosa tibia y un trapo húmedo suave para mantener el vidrio limpio. Seque con un trapo limpio- Puede usarse limpiador de vidrios si se requiere. Las fibras, los limpiadores abrasivos y los químicos pueden dañar el vidrio y el dibujo, por lo que no deben usarse.

En zonas de agua dura, las sales insolubles de cal pueden depositarse en el vidrio. Si se permite que se acumulen será cada vez más difícil retirarlas y se verá desagradable. La limpieza regular minimizará este efecto.

- No intente cortar el vidrio.
- No golpee el vidrio con artículos duros o puntiagudos.
- Compruebe con regularidad las partes móviles, como las ruedas y bisagras, para asegurarse de que están correctamente ajustadas. Apriételas y ajústelas cuando sea necesario. Compruebe también las juntas selladas para asegurarse de que el sellado no se ha deteriorado. Vuelva a sellarlo si fuera necesario.

As regras de ouro para os cuidados

NOTA: Utilize água morna com sabão e um pano macio húmido para manter o vidro limpo. Limpe com um pano seco. Pode utilizar um limpa-vidros, se necessário. Esfregões, substâncias abrasivas e substâncias químicas podem danificar o vidro e o padrão e não devem ser utilizados.

Em zonas de água calcária, poderão depositar-se resíduos insolúveis no vidro. Se se forem acumulando, torna-se cada vez mais difícil removê-los e o vidro torna-se inestético. Uma limpeza regular minimiza este efeito.

- Não tente cortar o vidro.
- Não bata no vidro com objetos rígidos ou pontiagudos.
- Verifique regularmente as peças móveis, como os roletes e as dobradiças, para garantir que estão devidamente fixos e ajustados. Aperte e ajuste sempre que necessário. Verifique igualmente se as uniões vedadas não apresentam sinais de deterioração. Vede novamente, se necessário.

Kullanım halindeyken altın kural

NOT: Camı temiz tutmak için ılık sabunlu su ve yumuşak nemli bir bez kullanın. Temiz bir bezle kurulayın. Arzu edilirse cam temizleyicisi kullanılabilir. Çözücüler, aşındırıcılar ve kimyasal temizleyiciler cama ve dokusuna zarar vereceğinden kullanılmamalıdır.

Suyu sert olan bölgelerde, çözünmeyen kireç tuzları camın üzerinde birikebilir. Bunun birikmesine izin verilirse çıkarılması giderek daha zor bir hal alır ve göze hoş görünmez. Düzenli temizlik bu etkiyi azaltır.

- Camı kesmeye çalışmayın.
- Cama sert veya sivri uçlu nesnelere vurmayın.
- Makara ve mafsal gibi hareketli parçaları düzenli olarak kontrol ederek sağlam ve ayarlarının doğru olduğundan emin olun. Gerekliğinde sıkın ve ayarlayın. Ayrıca contada çürüme, bozulma olmadığından emin olmak için tüm sızdırmazlık noktalarını kontrol edin. Gerekirse sızdırmazlığı yeniden sağlayın.